

Field Welding Steel Pile

Structural Field Welding and Inspection is the contract document that the inspector should become familiar with.

All welding must be done by a state-certified welder using the SMAW process. Documentation of the welder's certification and a photo id shall be shown prior to welding. The qualification test is not specific for welding steel piling and the type of weld used for the test is not the same type that is required for splicing piling. A certified welder may not be aware of how piling are to be welded.

Qualification Tests for Field Welding explains the qualification test for the welder and the classification system used to identify which types and positions of welding the welder is qualified to perform.

Pipe pile welding expectation are the same as shown but uses a backing ring.

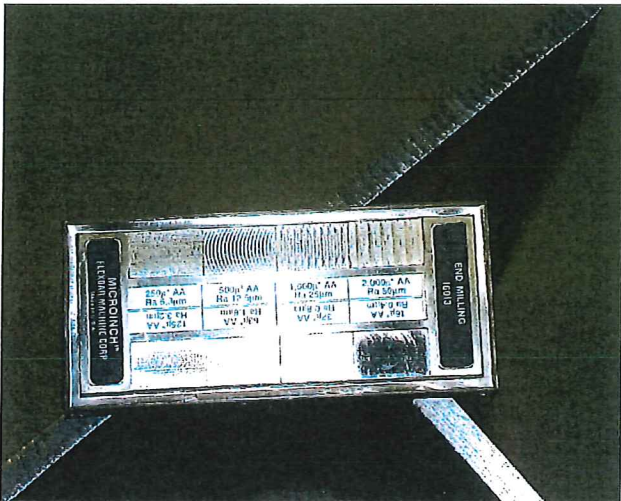

Picture 1

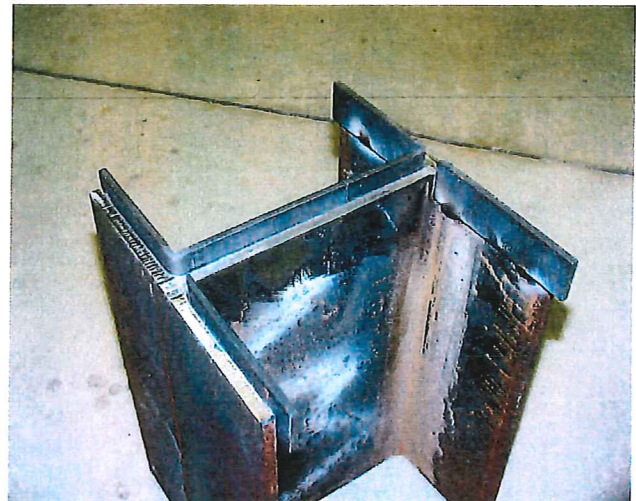

Picture 2

The top of the pile to be extended shall be square and all surfaces to be welded shall be cleaned with a grinder or wire brush and shall be dry and free of scale, slag, rust, moisture, grease and any other foreign material that would prevent proper welding. The surfaces to be welded shall also have a roughness of 1,000 micro-inches or less as compared to a surface roughness gauge. (pic. 1)

The backing plates may be tack welded in place if they are 1/4" to 3/8" thick. They shall be bent or ground to fit snug against the web and flanges. (pic. 2)

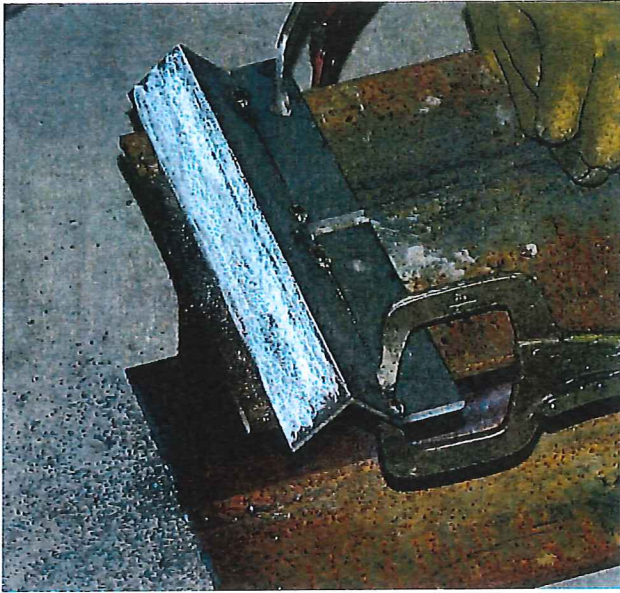

Picture 3

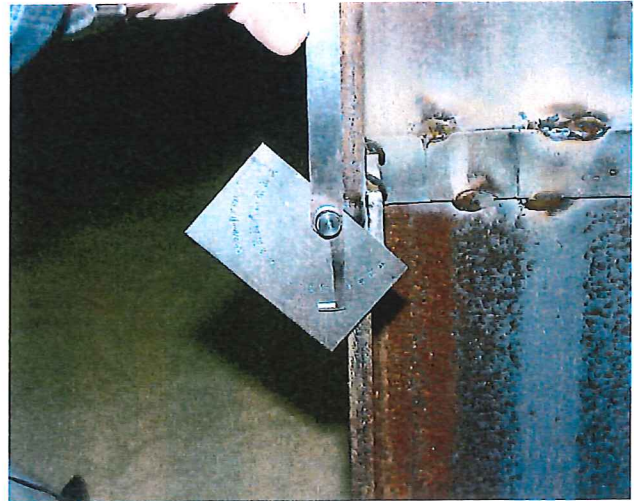

Picture 4

The bottom of the pile extension shall be beveled 45° on the outside of both flanges and on one side of the web. Clamping a piece of angle iron to the pile is one way of creating a guide to run the cutting torch along to help create the correct angle. If the contractor does a good job of cutting the bevel, minimal grinding will be required to meet the angle and roughness criteria. (pic. 3)

An angle measurement gauge can be used to determine if the bevel is within the $\pm 5^\circ$ tolerance. (pic. 4)

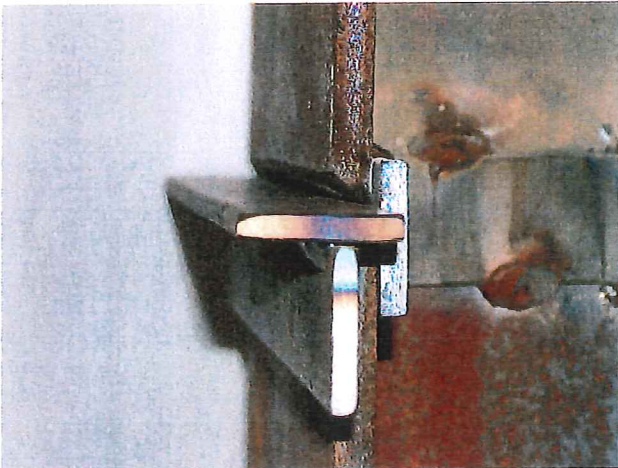

Picture 5

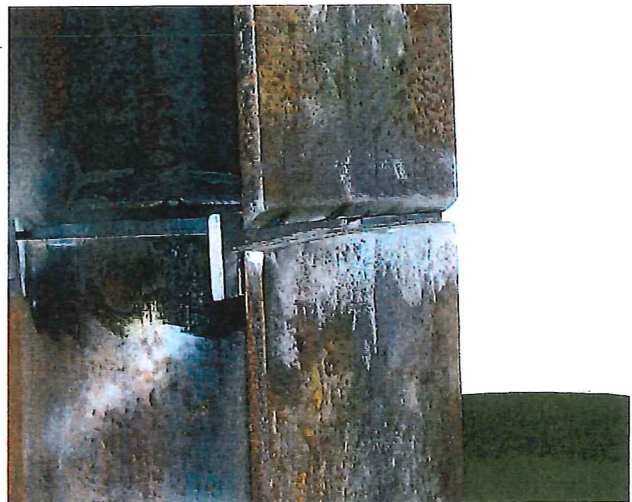

Picture 6

A 1/4 inch space (root opening) is required between the two sections of piling before welding them together. Picture 5 shows a 1/4 inch thick spacer being used to create the root opening within the given tolerances. The contractor can then tack weld the pile extension to the backer plates to hold it in position and then remove the spacer as shown in picture 6.

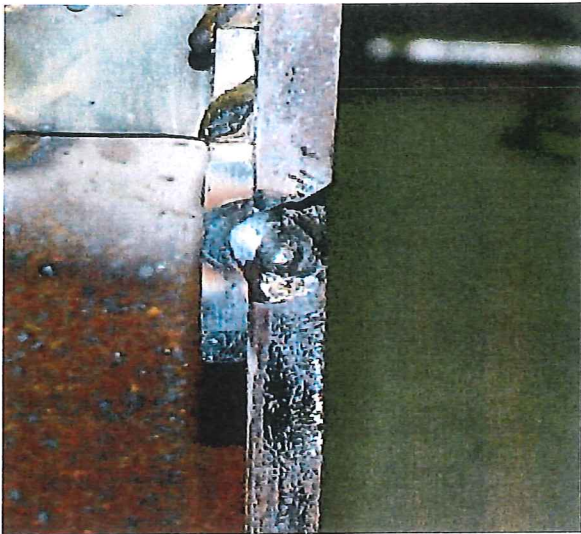

Picture 7



Picture 8

The root opening allows the welding electrode to arc against the backer plate and burn into it creating a full penetration weld. (pic. 7) If the root opening is not large enough, the welding electrode will arc before it reaches the backer plate and a full penetration weld will not be achieved.

Slag shall be removed with a chipping hammer and wire brush after each weld pass. (pic. 8)

A preheat temperature of 50° F is required before most metal piling is welded. Welding is not allowed when the ambient air temperature is below 0° F.



Picture 9

Welding E7018 electrodes shall be purchased in hermetically sealed containers. (pic. 9) After the container is opened the electrodes shall be used within 4 hours unless they have been stored in an oven at 250° F. After electrodes have been exposed for 4 hours, they shall be dried in an oven for at least two hours between 450° F and 500° F. Electrodes can only be redried one time therefore Electrodes should be purchased in small packages, allowing for use within the prescribed time limit, unless provisions for a larger oven are made.

Before any welding is started the contractor shall have the correct electrode and an electrode oven onsite.



Electrode Rod Oven

If reviewing the contract documents and communication with the welder is not effective, decertification of the welder may be pursued.

Field Welding Bearing Devices

Structural Field Welding and Inspection is the contract document that the inspector should become familiar with. Before any welding is started the contractor shall have the correct electrode and an electrode oven onsite.



Electrode Rod Oven

All welding must be done by a state-certified welder using the SMAW process. Documentation of the welder's certification and a photo id shall be shown prior to welding.

Qualification Tests for Field Welding explains the qualification test for the welder and the classification system used to identify which process and positions of welding the welder is qualified to perform.



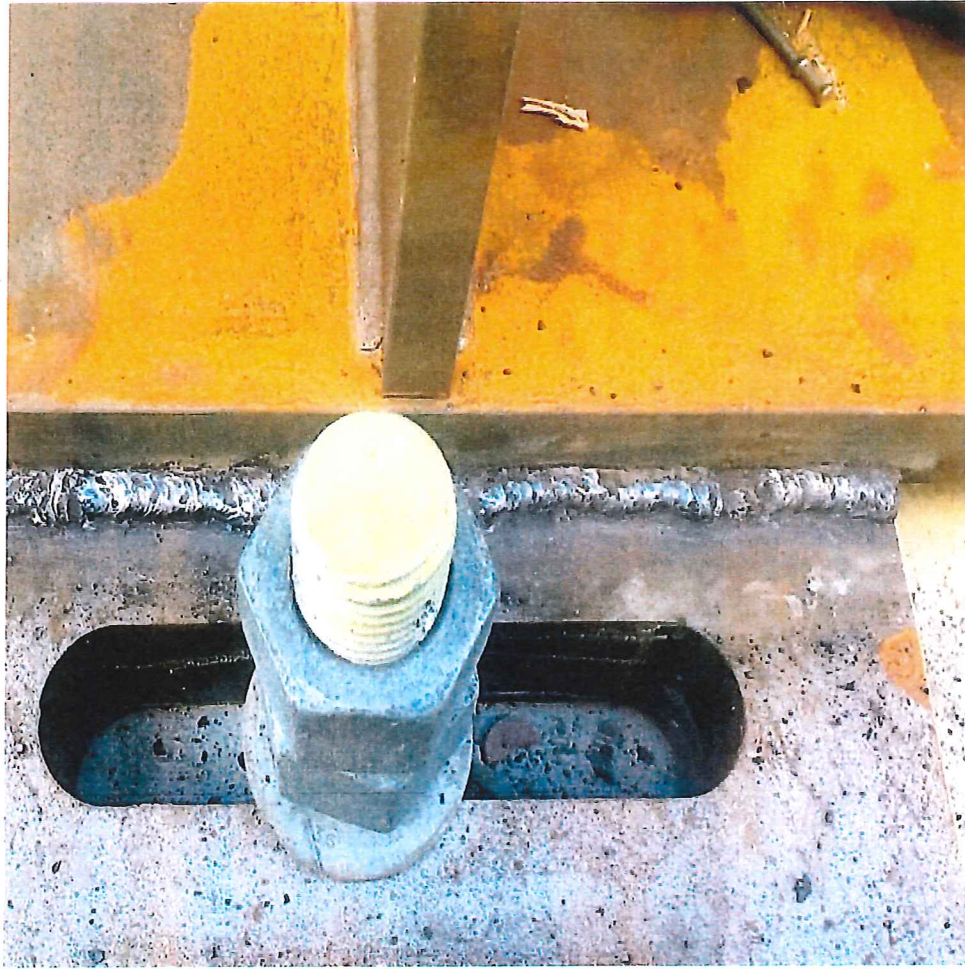

A single pass 5/16" Fillet weld shall be obtained.

All rust, moisture and contaminants shall be removed prior to welding.



Upon completion of welding all Slag shall be removed with a chipping hammer and wire brush.

A preheat temperature of 50° F is required before most metal piling is welded. Welding is not allowed when the ambient air temperature is below 0° F.



Welding E8018-C3 electrodes shall be purchased in hermetically sealed containers. E8018-C3 is a weathering steel electrode and must be used for welding weathering steel. After the container is opened the electrodes shall be used within 2 hours unless they have been stored in an oven at 250° F. After electrodes have been exposed for 2 hours, they shall be dried in an oven for at least two hours between 450° F and 500° F. Electrodes can only be redried one time therefore Electrodes should be purchased in small packages, allowing for use within the prescribed time limit. Unless provisions for a larger oven are made.

If the contractor obtains an Electrode with the H4R designator as shown below:



The electrode with H4R as optional designator, as defined in AWS A5.1-91 (Specification for shielded metal arc welding electrodes). Basically, the number after the "H" tells you the hydrogen level and the "R" means it's moisture resistant.

"R" identifies electrodes passing the absorbed moisture test after exposure to an environment of 80°F(26.7°C) and 80% relative humidity for a period up to 9 hours.

AASHTO/AWS D1.5M/D1.5:2015
An American National Standard

Bridge Welding Code

Mark Borgmann

Bridge Fabrication Manager | AWS-CWI #06030291

OFFICE 402-479-4763 CELL 402-416-4299 FAX 402-479-3753
mark.borgmann@nebraska.gov

Department of Transportation

1500 Highway 2
PO Box 94759
Lincoln, NE 68509-4759

dot.nebraska.gov

NEBRASKA
Good Life. Great Journey.

A Joint Publication of

AMERICAN ASSOCIATION
OF STATE HIGHWAY AND
TRANSPORTATION OFFICIALS

AASHTO



American Welding Society™



specification. Conversely, lower preheat temperatures may be adequate to prevent cracking, depending on restraint, hydrogen level, and actual steel composition or higher welding heat input.

- * **4.2.1 Minimum Preheat and Interpass Temperature.** The minimum preheat and interpass temperatures for redundant members shall be as specified in Table 4.3, except that preheat is not required for tack welding conforming to 3.3.7.1(1), stud welding, ESW, and EGW.

4.2.1.1 Minimum preheat and interpass temperatures may be established on the basis of steel composition, thickness, and restraint using recognized methods of prediction such as those provided in Annex G.

NOTE: These methods are based on laboratory cracking tests and may predict preheat temperatures higher than the minimum temperatures shown in Table 4.3. The guide may be of value in identifying situations where the risk of cracking is increased due to composition, restraint, hydrogen level, or welding heat input where higher heat input may be warranted. Alternatively, the guide may assist in defining conditions under which hydrogen cracking is unlikely and where the minimum requirements of Table 4.3 may be safely relaxed, based upon WPS qualification testing.

However, should the use of such guidelines result in temperatures lower than required by 4.2.1, the minimum temperature shall be qualified by performing tests acceptable to the Engineer.

4.2.1.2 Optional reduced preheat and interpass temperatures for M 270M/M 270 Grade HPS 690W [HPS 100W] (A709/A709M Grade HPS 100W [HPS 690W]) may be used in accordance with the requirements of Annex H.

4.2.2 Maximum Preheat and Interpass Temperature. The maximum preheat and interpass temperature shall be as specified in the WPS. For M 270M/M 270 (A709/A709M) Grade HPS 690W [HPS 100W], the maximum preheat and interpass temperature shall not exceed 205°C [400°F] for thicknesses up to 40 mm [1-1/2 in] inclusive, and 230°C [450°F] for greater thicknesses. For HPS 485W [HPS 70W], the maximum preheat and interpass temperature shall be 230°C [450°F] for all thicknesses.

4.2.2.1 Extent of Preheat. Preheat temperature shall be maintained during the welding operation for a distance at least equal to the thickness of the thickest welded part, but not less than 75 mm [3 in] in all directions from the edge of the weld joint, measured at the location of the welding arc.

* **4.2.2.2 Extent of Interpass.** The maximum interpass temperature shall be measured at a distance of 25 mm to

75 mm [1 in to 3 in] in all directions from the edge of the weld, measured just prior to welding the next pass.

4.2.3 Base Metal/Thickness Combinations. Temperature controls shall be based upon the thickness and grades of the base metal. For combinations of base metals, preheat and interpass temperatures shall be based upon the higher of the required temperatures.

4.2.4 Special Conditions. Thick material, or highly restrained joints or repair welds, shall be preheated by the Contractor above the minimum specified temperatures as required to prevent cracking or minimize lamellar tearing.

* **4.2.5 Minimum Ambient Temperature.** Welding shall not be done when the ambient temperature in the immediate vicinity of the weld is lower than -20°C [0°F]. The ambient environmental temperature may be lower than -20°C [0°F], provided supplemental heat and protection from the elements are sufficient to maintain a temperature adjacent to the weldment at -20°C [0°F], or higher.

4.2.6 Measurement of Temperature. When the base metal is below the temperature listed for the welding process being used and the thickness of material being welded, it shall be preheated in such a manner that the steel on which weld metal is being deposited is at or above the specified minimum temperature for a distance equal to the thickness of the part being welded, but not less than 75 mm [3 in] in all directions from the point of welding. To increase the effectiveness of preheat without increasing the temperature, at the Contractor's option, the area and depth that is heated may be increased beyond the minimum specified. There shall be no limit to the maximum area that may be preheated unless stated in the contract documents.

* **4.2.7 Minimum Base Metal Temperature.** When the base-metal temperature is below 0°C [32°F], the weld area shall be heated to at least 20°C [70°F], and this minimum temperature shall be maintained during welding.

4.2.8 Alternate SAW and Preheat Interpass Temperature. The minimum preheat and interpass temperature requirements for SAW made with parallel or multiple electrodes may be modified under the provisions of 4.10.4.

4.3 Heat Input Control for Grade HPS 690W [HPS 100W] Steel

When M 270M/M 270 Grade HPS 690W [HPS 100W] (A709/A709M Grade HPS 100W [HPS 690W]) steels are welded, welding heat input shall be appropriate for

the thickness of steel to be joined and the preheat and interpass temperature used. Heat input shall not exceed the manufacturers' recommendations. Table 12.5 may be used for guidance in welding M 270M/M 270 (A709/A709M) Grade HPS 690W [HPS 100W] steel.

4.4 Stress Relief Heat Treatment

4.4.1 General. Where required by the contract drawings or specifications, welded assemblies shall be stress-relieved by heat treating. Finish machining shall preferably be done after stress relieving. Thermal stress relieving of weldments involving M 270M/M 270 (A709/A709M) Grade HPS 690W [HPS 100W] steel is prohibited unless required to maintain dimensional stability or avoid stress corrosion-induced cracking. If heat treatment is required for tension elements, the contract may require prototype testing with similar configurations to evaluate effects on HAZ grain growth, ductility, and toughness.

4.4.2 Requirements. The stress relief treatment shall conform to the following requirements:

4.4.2.1 Initial Furnace Temperature. The temperature of the furnace shall not exceed 315°C [600°F] at the time the welded assembly is placed in it.

4.4.2.2 Rate of Heating. Above 315°C [600°F] the rate of heating in °C/hr shall not exceed 5600 divided by the maximum metal thickness in mm [in °F/hr the rate of heating shall not exceed 400°F per hour divided by the maximum metal thickness in inches], but not more than 220°C/hr [400°F/hr]. During the heating period, variation in temperature throughout the portion of the part being heated shall be no greater than 140°C [250°F] within any 5 m [15 ft] interval of length.

NOTE: The rates of heating and cooling need not be less than 55°C [100°F] per hour. However, in all cases, consideration of closed chambers and complex structures may indicate reduced rates of heating and cooling to avoid structural damage due to excessive thermal gradients.

4.4.2.3 Holding Time. After a maximum temperature of 600°C [1100°F] is reached on quenched and tempered steels, or a mean temperature range between 600°C [1100°F] and 650°C [1200°F] is reached on other steels, the temperature of the assembly shall be held within the specified limits for a time not less than specified in Table 4.4, based on weld thickness. When the specified stress relief is for dimensional stability, the holding time shall not be less than specified in Table 4.4, based on the thickness of the thicker part. During the holding period, the highest and lowest temperature throughout the portion of the assembly being heated shall not vary by greater than 85°C [150°F].

4.4.2.4 Rate of Cooling. Above 315°C [600°F], cooling shall occur in a closed furnace or cooling chamber at a rate in °C/hr not exceeding 7000 divided by the maximum metal thickness in mm [in °F/hr the cooling rate shall be no greater than 500°F per hour divided by the maximum metal thickness in inches], but not more than 280°C/hr [500°F/hr]. Below 315°C [600°F], the assembly may be cooled in still air.

4.4.3 Alternative PWHT. Alternatively, when it is impractical to postweld heat treat to the temperature limitations described in 4.4.2, welded assemblies may be stress-relieved at lower temperatures for longer periods of time, as given in Table 4.5.

* Part B

Shielded Metal Arc Welding (SMAW)

4.5 Electrodes for SMAW

4.5.1 SMAW Electrodes. Electrodes for SMAW shall conform to the requirements of the latest edition of AWS A5.1/A5.1M, *Specification for Carbon Steel Electrodes for Shielded Metal Arc Welding*, or to the requirements of AWS A5.5/A5.5M, *Specification for Low-Alloy Steel Electrodes for Shielded Metal Arc Welding*. All electrodes for SMAW shall be of the low-hydrogen classification.

* **4.5.2 Low-Hydrogen Drying Requirements.** All electrodes having low-hydrogen coverings conforming to AWS A5.1/A5.1M shall be purchased in hermetically sealed containers or shall be dried in conformance with the manufacturer's written drying instructions. Electrodes having a low-hydrogen covering conforming to AWS A5.5/A5.5M shall be purchased in hermetically sealed containers or shall be dried at least one hour at temperatures between 370°C [700°F] and 425°C [800°F] before being used. Electrodes shall be dried prior to use if the hermetically sealed container shows evidence of damage. Immediately after opening of the hermetically sealed container or removal of the electrodes from drying ovens, electrodes shall be stored in ovens held at a temperature of at least 120°C [250°F]. After the opening of hermetically sealed containers or removal from drying or storage ovens, electrode exposure to the atmosphere shall not exceed the requirements of 4.5.2.1. TABLE 4.6

* **4.5.2.1 Approved Atmospheric Exposure Periods.** Electrodes exposed to the atmosphere upon removal from drying or storage ovens or hermetically sealed containers shall be used within the time limit shown in Table 4.6 or redried at 230°C to 290°C [450°F to 550°F] for two hours minimum, except as provided in 4.5.2.3.

4.5.2.2 Short Exposure Times. Electrodes exposed to the atmosphere for periods less than those allowed by Table 4.6 may be returned to a holding oven maintained at 120°C [250°F] minimum and after a minimum period of four hours at that temperature may be reissued. The provisions of 4.5.4 shall apply.

4.5.2.3 Optional Supplemental Moisture-Resistant Designators. Electrodes with the AWS filler metal specifications optional supplemental moisture resistance designator "R" may be exposed to the atmosphere for up to nine hours when welding steels with a minimum specified yield strength of 345 MPa [50 ksi] or less. Moisture-resistant electrodes shall be received in containers that bear the additional designator "R" as part of the AWS classification.

4.5.3 Electrode Restrictions for Grade HPS 690W. When used for welding M 270M/M 270 (A709/A709M) Grade HPS 690W [HPS 100W] steel, electrodes shall be dried at least one hour at temperatures between 370°C and 425°C [700°F and 800°F] before being used, whether furnished in hermetically sealed containers or otherwise.

* **4.5.4 Redrying Electrodes.** Electrodes that conform to the provisions of 4.5.2 shall be redried no more than one time. Electrodes that have been wet shall not be used.

4.6 Procedures for SMAW

4.6.1 Flat Position. The work shall be positioned for flat position welding whenever practical.

4.6.2 Suitability. The classification and size of electrode, arc length, voltage, and amperage shall be suited to the thickness of the material, type of groove, welding positions, and other circumstances attending the work. Welding current shall be within the range recommended by the electrode manufacturer.

* **4.6.3 Maximum Electrode Diameter.** The maximum diameter of electrodes shall be as follows:

- (1) 6.4 mm [1/4 in] for all welds made in the flat position, except root passes
- (2) 6.4 mm [1/4 in] for horizontal fillet welds
- (3) 6.4 mm [1/4 in] for root passes of fillet welds made in the flat position and groove welds made in the flat position with backing and with a root opening of 6 mm [1/4 in] or more
- (4) 4.0 mm [5/32 in] for welds made in the vertical and overhead position

(5) 5.0 mm [3/16 in] for root passes of groove welds and for all other welds not included under 4.6.3(1), (2), (3), and (4)

4.6.4 Minimum Root Pass Size. The minimum size of a root pass shall be sufficient to prevent cracking.

4.6.5 Maximum Root Pass Thickness. The maximum thickness of root passes in groove welds shall be 6 mm [1/4 in].

4.6.6 Maximum Single-Pass Fillet Weld Size. The maximum size of single-pass fillet welds and root passes of multiple-pass fillet welds shall be as follows:

- (1) 10 mm [3/8 in] in the flat position
- (2) 8 mm [5/16 in] in the horizontal or overhead positions
- (3) 12 mm [1/2 in] in the vertical position

4.6.7 Maximum Fill Pass Thickness. The maximum thickness of layers subsequent to root passes of groove and fillet welds shall be as follows:

- (1) 3 mm [1/8 in] for subsequent layers of welds made in the flat position
- (2) 5 mm [3/16 in] for subsequent layers of welds made in the vertical, overhead, or horizontal positions

4.6.8 Vertical Progression. The progression for all passes in the vertical position shall be upward, unless a downward progression is qualified by tests approved by the Engineer.

4.6.9 CJP Backgouging. CJP groove welds made without the use of steel backing shall have the root gouged to sound metal before welding is started from the second side.

Part C *Submerged Arc Welding (SAW)*

4.7 General Requirements

4.7.1 SAW Electrodes. SAW may be performed with one or more single electrodes, one or more parallel electrodes, or combinations of single and parallel electrodes. The spacing between arcs shall be such that the slag cover over the weld metal produced by a leading arc does not cool sufficiently to prevent the proper weld deposit of a following electrode. SAW with multiple electrodes may be used for any groove or fillet weld pass.

Table 4.4
Minimum Holding Time (see 4.4.2)

6 mm [1/4 in] or Less	Over 6 mm [1/4 in] Through 50 mm [2 in]	Over 50 mm [2 in]
15 minutes	4 minutes/2 mm [1/16 in]	2 hrs plus 15 minutes for each additional 25 mm over 50 mm [1 in over 2 in]

Table 4.5
Alternate Stress-Relief Heat Treatment (see 4.4.3)

Decrease in Temperature Below Minimum Specified Temperature, Δ °C [°F]	Minimum Holding Time at Decreased Temperature, Hours per 25 mm [1 in] of Thickness
30 [50]	2
60 [100]	3
90 [150]	5
120 [200]	10

*** Table 4.6 ***
Allowable Atmospheric Exposure of Low-Hydrogen SMAW Electrodes

AWS Filler Metal Specification	Electrode	Hours
A5.1	E70XX	4 max.
A5.5	E70XX-X	4 max.
	E80XX-X	2 max.
	E90XX-X	1 max.
	E100XX-X	1/2 max.
	E110XX-X	1/2 max.

Table 4.7
Required Voltage for ESW

Wire Diameter	Single Wire	Two Wires
2.4 mm [3/32 in]	33 V-37 V	31 V-36 V
1.6 mm [1/16 in]	29 V-35 V	28 V-33 V

Customer: NEBRASKA DEPARTMENT OF ROADS
 Location: BRIDGE DIVISION
 County: 1500 HWY 2 P.O. BOX 94759
 Project: LINCOLN, NE. 68509-4759
 Job:

Welding Procedure Specification

Material Specification, ASTM A709-Gr50W / M270-Gr50W

Welding Process: Shielded Metal Arc Welding (SMAW)

Manual or Machine: Manual	Single or Multiple Pass: Single / Multiple Pass
Position of Weld: All	Single or Multiple Arc: Single Arc
Filler Metal Spec.: AWS A5.5	Welding Current: AC \ DC
Filler Metal Class: E8018 - C3 Lincoln Electric	Polarity: Electrode Positive

Root Treatment: REMOVE ALL TRACES OF RUST, SLAG, OIL OR FOREIGN MATTER

Preheat & Interp. Temp: to 3/4" = 50° F, over 3/4" to 1 1/2" = 70° F, 1 1/2" to 2 1/2" = 150° F, over 2 1/2" = 225° F

Maximum Interpass Temp:

Pass No.	Electrode Size	Welding Current		Travel IPM	Weld Size
		Amperes	Volts		
1	1/8	AC 120-170 DC 110-150	22 -30		1/4
1	5/32	AC 140-225 DC 130-190	22 -30		1/4
1 - 2	5/32	AC 140-225 DC 130-190	22-30		5/16
2 - 3	5/32	AC 140-225 DC 130-190	22-30		3/8
1 - 2	3/16	AC 210-290 DC 190-270	22-30		5/16
2 - 3	3/16	AC 210-290 DC 190-270	22-30		3/8

Miscellaneous Fillet Welds

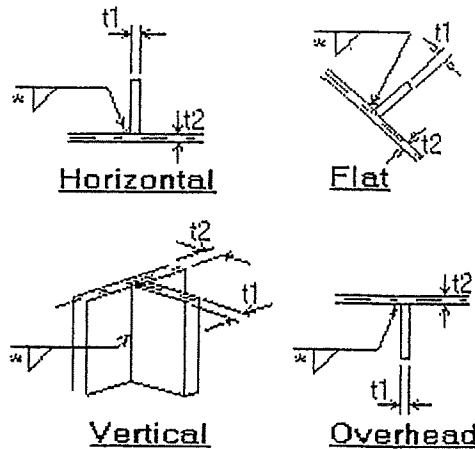

Notes:
 1. * Weld Size

This Procedure may vary due to fabrication sequence, fit up, pass size, etc. within the limitations of variables given in section 2, 3, 4 and 5 of AWS D1.5 - 2008

Detailed By: CRA

Authorized By: [Signature]

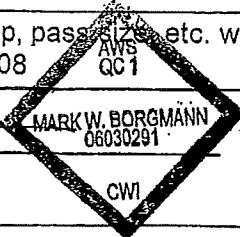

Procedure No. NE-001

Checked By: [Signature]

Date: 3/27/09

Revision No. _____