

# Design and Detailing of Cast-in-Place and Precast Concrete Approach Slabs

Nebraska Department of Transportation (NDOT)

Project No. M108

*Final Report*



May 2021

# **Design and Detailing of Cast-in-Place and Precast Concrete Approach Slabs**

A Report on Research Sponsored by

Nebraska Department of Transportation (NDOT)

## **Principle Investigator**

George Morcous, Ph.D., P.E.

Durham School of Architectural Engineering and Construction (DSAEC), College of  
Engineering, University of Nebraska-Lincoln (UNL)

## **Research Assistant**

Mostafa Abo El-Khier, Ph.D. Candidate

Durham School of Architectural Engineering and Construction (DSAEC), College of  
Engineering, University of Nebraska-Lincoln (UNL)

May 2021

## TECHNICAL REPORT DOCUMENTATION PAGE

<b>1. Report No.</b> M108	<b>2. Government Accession No.</b>	<b>3. Recipient's Catalog No.</b>	
<b>4. Title and Subtitle</b> Design and Detailing of Cast-in-Place and Precast Concrete Approach Slabs		<b>5. Report Date</b> May 31, 2021	
		<b>6. Performing Organization Code</b>	
<b>7. Author(s)</b> George Morcoux and Mostafa Abo-Elkhier		<b>8. Performing Organization Report No.</b> No.	
<b>9. Performing Organization Name and Address</b> Durham School of Architecture Engineering and Construction University of Nebraska-Lincoln Omaha, Nebraska 68182-0178		<b>10. Work Unit No.</b>	
		<b>11. Contract</b> SPR-1(20) (M108)	
<b>12. Sponsoring Agency Name and Address</b> Nebraska Department of Transportation Research Section 1400 Hwy 2 Lincoln, NE 68502		<b>13. Type of Report and Period Covered</b> Final Report July 2019-May 2021	
		<b>14. Sponsoring Agency Code</b>	
<b>15. Supplementary Notes</b>			
<b>16. Abstract</b> <p>Approach slab is a structural concrete slab that spans from the backwall of the abutment (i.e. end of the bridge floor) to the beginning of the paving section. The purpose of the approach slab is to carry the traffic loads over the backfill behind the abutments to avoid differential settlement that causes bumps at the bridge ends. Cast-in-place concrete approach slab is the current practice in US with various spans, reinforcement, thicknesses, joints, and concrete covers. NDOT has observed premature cracking in a significant number of approach slabs, which could result in a shorter service life and costly repairs/replacements as well as traffic closures and detours. The objective of this project is to investigate the extent and causes of approach slab cracking and propose necessary design, detailing and construction changes that could mitigate this deterioration. The literature on current approach slab practices by other state DOTs is reviewed and an analytical investigation is conducted using finite element analysis to evaluate the performance of different approach slabs under live load, volume changes due to shrinkage and temperature, and soil friction. Several parameters are considered in this investigation, skew angle, bridge width, joint location, and connection type. Analysis results indicate that volume changes cause high tensile stresses along abutment line, which result in the observed cracking. Several design changes are proposed and precast concrete approach slab alternatives are considered as promising solutions that could result in longer service life and accelerated construction.</p>			
<b>17. Key Words</b> Approach Slab, Shrinkage Cracking, Accelerated Construction, Precast Slabs		<b>18. Distribution Statement</b> No restrictions. This document is available through the National Technical Information Service. 5285 Port Royal Road Springfield, VA 22161	
<b>19. Security Classification (of this report)</b> Unclassified	<b>20. Security Classification (of this page)</b> Unclassified	<b>21. No. of Pages</b> 95	<b>22. Price</b>

## **DISCLAIMER**

The contents of this report reflect the views of the authors, who are responsible for the facts and the accuracy of the information presented herein. The contents do not necessarily reflect the official views or policies neither of the Nebraska Department of Transportations nor the University of Nebraska-Lincoln. This report does not constitute a standard, specification, or regulation. Trade or manufacturers' names, which may appear in this report, are cited only because they are considered essential to the objectives of the report.

The United States (U.S.) government and the State of Nebraska do not endorse products or manufacturers. This material is based upon work supported by the Federal Highway Administration under SPR-1(20) (M108). Any opinions, findings and conclusions or recommendations expressed in this publication are those of the author(s) and do not necessarily reflect the views of the Federal Highway Administration.”

## **ACKNOWLEDGEMENTS**

Funding for this project was provided by the Nebraska Department of Transportation (NDOT) under project number SPR-P1(20) M108 – Design and Detailing of Cast-in-Place and Precast Concrete Approach Slabs. The authors would like to express their gratitude for the support and guidance provided by the NDOT Technical Advisory Committee. Findings and conclusions of this project are of the authors and do not reflect the sponsor agencies and collaborators.

## **ABSTRACT**

Approach slab is a structural concrete slab that spans from the backwall of the abutment (i.e. end of the bridge floor) to the beginning of the paving section. The purpose of the approach slab is to carry the traffic loads over the backfill behind the abutments to avoid differential settlement that causes bumps at the bridge ends. Cast-in-place concrete approach slab is the current practice in US with various spans, reinforcement, thicknesses, joints, and concrete covers. NDOT has observed premature cracking in a significant number of approach slabs, which could result in a shorter service life and costly repairs/replacements as well as traffic closures and detours. The objective of this project is to investigate the extent and causes of approach slab cracking and propose necessary design, detailing and construction changes that could mitigate this deterioration. The literature on current approach slab practices by other state DOTs is reviewed and an analytical investigation is conducted using finite element analysis to evaluate the performance of different approach slabs under live load, volume changes due to shrinkage and temperature, and soil friction. Several parameters are considered in this investigation, skew angle, bridge width, joint location, and connection type. Analysis results indicate that volume changes cause high tensile stresses along abutment line, which result in the observed cracking. Several design changes are proposed and precast concrete approach slab alternatives are considered as promising solutions that could result in longer service life and accelerated construction.

## Table of Contents

ABSTRACT.....	i
Table of Contents .....	ii
List of Figures and Tables.....	iv
Chapter 1. Introduction.....	7
1.1. Background.....	7
1.2. Objectives.....	8
1.3. Report Outline.....	8
Chapter 2 Cast-in-Place Concrete Approach Slabs.....	10
2.1. Introduction.....	10
2.2. Current Practices.....	10
2.2.1. Nebraska.....	11
2.2.2. California.....	13
2.2.3. Washington.....	14
2.2.4. Missouri.....	15
2.2.5. Iowa.....	17
2.2.6. Colorado.....	17
2.3. Survey Results.....	20
Chapter 3. Condition Evaluation.....	27
3.1 Field Observations.....	27
3.2 Inspection Records.....	40
Chapter 4. Analytical Investigation.....	48
4.1 Introduction.....	48
4.2 Effect of Skew Angle.....	50
4.3 Effect of Roadway Width.....	54
4.4 Effect of Longitudinal Joint Type.....	56
4.5 Effect of Abutment Connector Type.....	58
4.6 Effect of Soil Friction.....	61
4.7 Proposed Changes.....	62
Chapter 5. Precast Concrete Approach Slabs.....	64
5.1 Introduction.....	64

5.2 Current Practices.....	64
5.3 Proposed Alternatives .....	79
<b>Chapter 6. Conclusions and Lessons Learned.....</b>	<b>84</b>
6.1. Conclusions .....	84
6.2. Lessons Learned.....	85
<b>REFERENCES.....</b>	<b>86</b>
<b>APPENDIX A: Proposed Specifications .....</b>	<b>88</b>
<b>APPENDIX B: Design Calculations .....</b>	<b>93</b>
<b>APPENDIX C: Precast Concrete Approach Slab Construction.....</b>	<b>107</b>



## List of Figures and Tables

Figure 1.1: Cracking of bridge approach slabs .....	7
Figure 2.1: Approach Slab Terminology.....	10
Figure 2.2: NDOT Typical Approach Slab Design and Detailing .....	12
Figure 2.3: Caltrans Typical Approach Slab Design and Detailing .....	13
Figure 2.4: Caltrans Abutment tie Details.....	14
Figure 2.5: WSDOT Approach Slab Design and Detailing .....	15
Figure 2.6: MoDOT Approach Slab Design and Detailing .....	16
Figure 2.7: IowaDOT Approach Slab Design and Detailing .....	17
Figure 2.8: CDOT Approach Slab Design and Detailing.....	18
Table 2.1. Summary of approach slab designs .....	19
Figure 2.9: Anchorage bar layout in approach slab-abutment connection .....	19
Table 2.2 Results of Approach Slab Survey (Thiagarajan et.al., 2010).....	21
Figure 2.10: Span length frequency distribution.....	22
Figure 2.11: Slab depth frequency distribution.....	22
Figure 2.12: Span-to-depth ratio frequency distribution .....	23
Figure 2.13: Reinforcement ratio frequency distribution.....	23
Figure 2.14: Distribution of approach slab primary problems .....	24
Figure 2.15: Distribution of approach slab cracking directions .....	25
Figure 2.16: Distribution of the material used underneath approach slabs .....	25
Figure 2.17: Distribution of approach slab type of support at pavement end.....	26
Figure 3.1: Plan view of Ayr Bridge.....	27
Figure 3.2: Ayr bridge connection detail at the grade beam .....	28
Figure 3.3: Ayr bridge cracking map.....	28
Figure 3.4: Ayr bridge approach slab and paving section cracking .....	30
Figure 3.5: Cracking map of approach slab and paving section of Little Sandy Creek bridge. ....	31
Figure 3.6: Little Sandy Creek bridge approach slab and paving section cracking .....	32
Figure 3.7: Cracking map of approach slab and paving section of Turkey Creek bridge .....	33
Figure 3.8: Turkey Creek bridge approach slab and paving section cracking .....	34
Figure 3.9: Photos of approach slab and paving section cracking at different bridges .....	39
Figure 3.10: Bridge paving, approach, and main spans as well as their elements.....	41
Figure 3.11: Definitions of condition ratings for different element defects.....	42
Figure 3.12: Frequency distribution of age of the considered NDOT approach slabs .....	43
Figure 3.13: Frequency distribution of skew angle of the considered NDOT approach slabs.....	43
Figure 3.14: Frequency distribution of roadway clear width of the considered NDOT approach slabs .....	44
Figure 3.15: Plots of ADT and % of truck traffic for considered NDOT approach slabs .....	44
Figure 3.16: Relationship between age and % of cracked area .....	45
Figure 3.17: Relationship between skew angle and % of cracked area .....	45
Figure 3.18: Relationship between roadway clear width and % of cracked area .....	46
Figure 3.19: Relationship between ADT and % of cracked area .....	46
Figure 3.20: Relationship between % truck and % of cracked area .....	47
Figure 4.1: Parameters considered in the analytical investigation.....	48
Figure 4.2: Solid Element geometry.....	49
Figure 4.3: Shell Element geometry.....	49

Figure 4.4: Extruded view of the approach slab model.....	50
Figure 4.5: Design live load configurations.....	50
Figure 4.6: Models of approach slabs with different skew angles.....	51
Figure 4.7: Slab bottom longitudinal stresses (ksi) due to dead and live loads .....	51
Figure 4.8: Longitudinal force effect reduction factor at different skew angles.....	51
Figure 4.9: Slab deflections (in.) due to dead and live loads.....	52
Figure 4.10: Direction of principal bottom stresses (ksi) in skewed approach slab .....	52
Figure 4.11: Proposed direction of longitudinal reinforcement in skewed approach slabs and corresponding AASHTO LRFD Section .....	53
Figure 4.12: Proposed orientation of longitudinal reinforcement in approach slabs with no, low and high skew angles .....	53
Figure 4.13: Slab top principal stresses (ksi) due to volume changes .....	54
Figure 4.14: Directions of slab top principal stresses (ksi) due to volume changes .....	54
Figure 4.15: Models of approach slabs with different roadway width .....	55
Figure 4.16: Slab bottom longitudinal stresses (ksi) due to dead and live loads .....	55
Figure 4.17: Slab top principal stresses (ksi) due to volume changes .....	56
Figure 4.18: Typical longitudinal joint in approach slab .....	56
Figure 4.19: Typical NDOT construction joint .....	57
Figure 4.20: IowaDOT KS-2 longitudinal contraction joint (King, 2020) .....	57
Figure 4.21: Models of approach slabs with different types of longitudinal joints.....	57
Figure 4.22: Slab top principal stresses (ksi) due to volume changes .....	58
Figure 4.23: Current practice of using #6 @12 in. dowels to connect approach slab at the abutment.....	58
Figure 4.24: Methods of providing sleeved connectors .....	59
Figure 4.25: Models of approach slabs with sleeved connectors.....	59
Figure 4.26: Slab bottom longitudinal stresses (ksi) due to dead and live loads with sleeved connectors .....	60
Figure 4.27: Slab top principal stresses (ksi) due to volume changes using: a) #6@12"; and b) #7@24" sleeved connectors .....	60
Figure 4.28: Slab top principal stresses (ksi) due to volume changes with considering soil friction .....	61
Figure 4.29: Slab top principal stresses (ksi) due to abutment movement with considering soil friction .....	61
Figure 4.30: Slab top principal stresses (ksi) due to differential settlement .....	62
Figure 5.1: Classification of Precast Concrete Approach Slabs.....	65
Figure 5.2: Full-Width Precast Concrete Approach Slabs (Merritt et.al., 2007) .....	65
Figure 5.3: Partial-Width Full-Length Precast Concrete Approach Slabs .....	66
Figure 5.4: Partial-Width Partial-Length Precast Concrete Approach Slabs (Merritt et.al., 2007) .....	66
Figure 5.5: Surface approach slab (top) and sub-surface approach (bottom) (PCI, 2012) .....	67
Figure 5.6: Options of longitudinal joints (PCI, 2012).....	67
Figure 5.7: Connections at the abutment (left) and at sleeper slab (right) (PCI, 2012).....	67
Figure 5.8: Plan view of precast post-tensioned approach slab panels (Merritt et.al, 2007) .....	68
Figure 5.9: Transverse joint detail (Merritt et.al, 2007).....	68
Figure 5.10: Longitudinal joint detail (Merritt et.al, 2007).....	69
Figure 5.11: Connection to the abutment (Merritt et.al, 2007) .....	69
Figure 5.12: Connection to paving section (Merritt et.al, 2007).....	69
Figure 5.13: Plan view of precast concrete approach slab panels (Ziehl et.al., 2015) .....	70
Figure 5.14: Interior panel showing formed sleeves and U bars (Ziehl et.al., 2015) .....	70
Figure 5.15: Plan and elevation views of longitudinal joint (Ziehl et.al., 2015) .....	71
Figure 5.16: Plan view of precast approach slab panels (Gudimetla, 2012).....	72

<i>Figure 5.17: Cross section in one panel (Gudimetla, 2012)</i> .....	72
<i>Figure 5.18: Longitudinal section of the approach slab (Gudimetla, 2012)</i> .....	72
<i>Figure 5.19: Plan and section views of approach slab with no skew (IDOT, 2017)</i> .....	73
<i>Figure 5.20: Cross section of approach slab near abutment (IDOT, 2017)</i> .....	73
<i>Figure 5.21: Longitudinal Joint detail A (IDOT, 2017)</i> .....	74
<i>Figure 5.22: Reinforcement of precast concrete approach slab panel (IDOT, 2017)</i> .....	74
<i>Figure 5.23: Plan view of the precast approach slab and paving section panels (Belden-Laurel Bridge)</i> .....	75
<i>Figure 5.24: Longitudinal joint between precast concrete panels (Belden-Laurel Bridge)</i> .....	75
<i>Figure 5.25: Transverse joint between precast concrete approach slab and bridge deck (Belden-Laurel Bridge)</i> .....	75
<i>Figure 5.26: Cross section of precast concrete panels of the paving section and their connection to the grade beam (Belden-Laurel Bridge)</i> .....	76
<i>Figure 5.27: Plan and section views of an interior precast concrete panel of the paving section and its connection to the grade beam (I-680/West Center Road Bridge)</i> .....	77
<i>Figure 5.28: Connection of the precast concrete panel of the paving section to the grade beam (I-680/West Center Road Bridge)</i> .....	77
<i>Figure 5.29: Longitudinal joints between precast concrete panels of the paving section (I-680/West Center Road Bridge)</i> .....	77
<i>Figure 5.30: Proposed alternatives of non-prestressed precast concrete approach slabs</i> .....	79
<i>Figure 5.31: Alternatives of longitudinal joints</i> .....	80
<i>Figure 5.32: Alternatives of panel end connection</i> .....	80
<i>Figure 5.33: Comparing design of precast concrete approach slab using Grade 60 A615 and Grade 100 A1035 reinforcing steel</i> .....	81
<i>Figure 5.34: Comparison of typical stress-strain curves for ASTM A615 and ASTM A1035 reinforcement bars (ACI 439-19)</i> .....	81

# Chapter 1. Introduction

## 1.1. Background

The approach slab is a structural concrete slab designed to span from the backwall of the abutment (i.e. end of the bridge floor) to the grade beam or sleeper slab where the paving section begins. The purpose of the approach slab is to carry the dead load and live load of traffic over the backfill behind the abutments to avoid possible settlement of the backfill that causes bump at the end of the bridge. Despite the simplicity of cast-in-place (CIP) concrete approach slab designed as a simply supported one-way reinforced concrete slab, it has been reported by Nebraska Department of Transportation (NDOT) that a significant number approach slabs experience cracking at early ages. Figure 1 shows examples of this cracking that is primarily longitudinal cracking starting at and perpendicular to the backwall support line. This cracking results in premature deterioration of the approach slabs, shorter service life, and costly repairs/replacements. The causes of this cracking are not clearly understood.



*Figure 1.1: Cracking of bridge approach slabs*

On the other hand, NDOT recently considered the use of precast concrete (PC) approach slabs to achieve higher quality and faster construction than CIP concrete approach slabs. The first implementation of precast concrete approach slabs was completed in the summer of 2018 in the construction of Belden-Laurel Bridge. Several lessons were learned from this project, which could be considered to improve the design, fabrication, and construction of precast concrete approach slabs. Therefore, it is important and timely to re-visit the current design, detailing, and construction practice of current CIP and PC approach slabs in order to improve their durability and speed of construction.

## 1.2. Objectives

The main objectives of this research project is to:

1. Investigate causes of premature deterioration of CIP concrete approach slabs
2. Propose a refined design and detailing of CIP concrete approach slabs
3. Propose design alternatives to enhance the design/construction of PC approach slabs
4. Recommend changes to NDOT approach slab policy

## 1.3. Report Outline

This report consists of six chapters as follows.

**Chapter 1 – Introduction:** This chapter discusses the background of the problem and research objectives

**Chapter 2 – Cast-in-Place Approach Slabs:** The chapter presents the current practices of several DOTs at different geographical regions in designing and detailing of CIP concrete approach slabs. Results of recent surveys were also summarized to present the differences in approach slab design and construction practices in US.

**Chapter 3 – Condition Evaluation:** The chapter presents the outcome of three field visits to observe the cracking in bridge approach slabs and paving sections. Also, analysis of element inspection data of approximately 500 records in NDOT database is presented to determine the effect of parameters, such as age, skew angle, bridge width, and traffic volume, on the cracking of approach slabs.

**Chapter 4 – Analytical Investigation:** The chapter presents the finite element analysis conducted to study the effect of skew angle, bridge width, longitudinal joint, abutment connection, and soil friction on the stresses in the approach slabs under live loads and volume changes due to shrinkage and temperature. It also presented the proposed changes to reduce these stresses and control approach slab cracking.

**Chapter 5 – Precast Concrete Approach Slabs:** The chapter presents the different types of precast concrete approach slabs and the designs proposed by PCI as well as current practices in Iowa, South Carolina, Illinois, Missouri, and Nebraska. Design alternatives are proposed using both high-early strength concrete and ultra-high performance concrete in combination with Grade 60 steel and high strength steel.

**Chapter 6 –Conclusions and Lessons Learned:** This chapter presents a summary of the report main conclusions drawn from the finite element analysis of approach slab, design and detailing of CIP and precast concrete approach slabs and design recommendations. It also presents the lessons learned from the production and construction of precast concrete approach slabs.

## Chapter 2 Cast-in-Place Concrete Approach Slabs

### 2.1. Introduction

This chapter presents the literature review on the current practices of different US Departments of Transportation (DOTs), including NDOT, in designing and detailing cast-in-place (CIP) concrete approach slabs. Recent surveys that shows the difference in approach slab dimensions and reinforcement among DOTs are discussed as well as the common deterioration mechanisms and their possible causes. Figure 2.1 shows the plan view of a typical approach slab and the terminology used to describe its parameters.

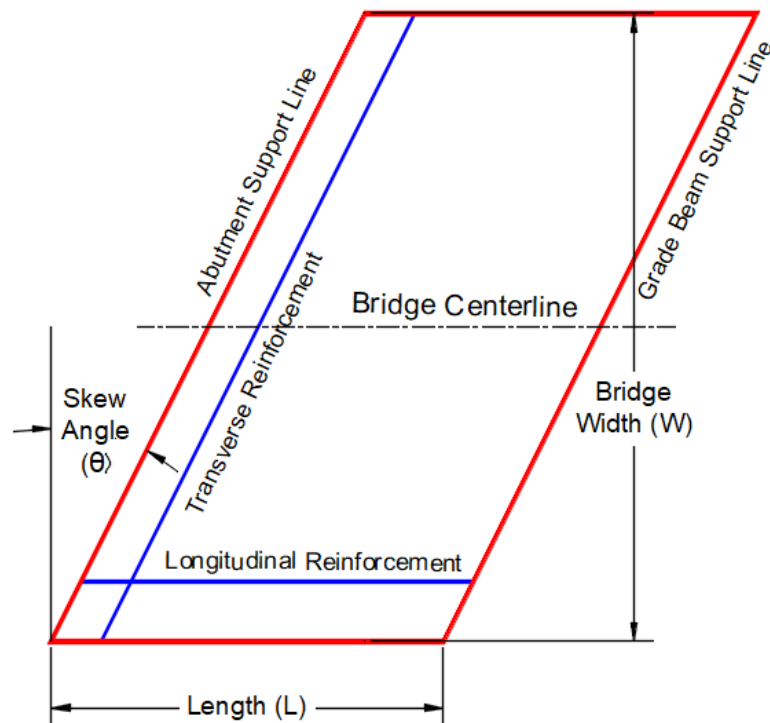


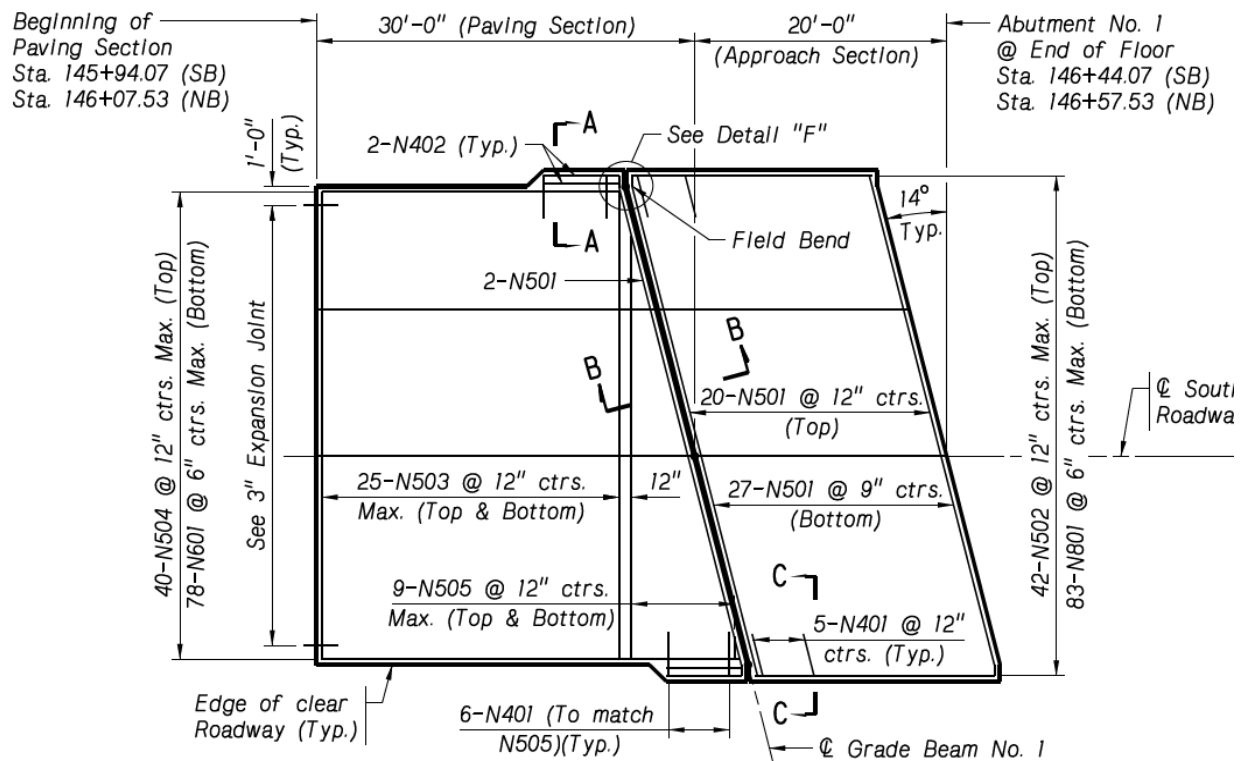
Figure 2.1: Approach Slab Terminology

### 2.2. Current Practices

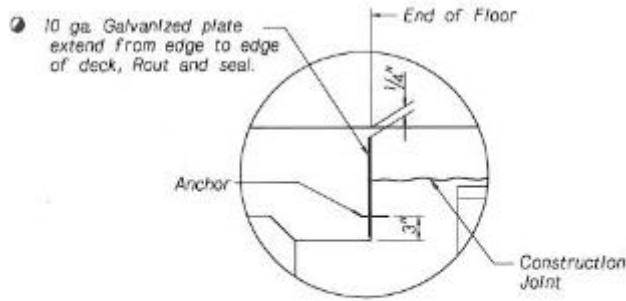
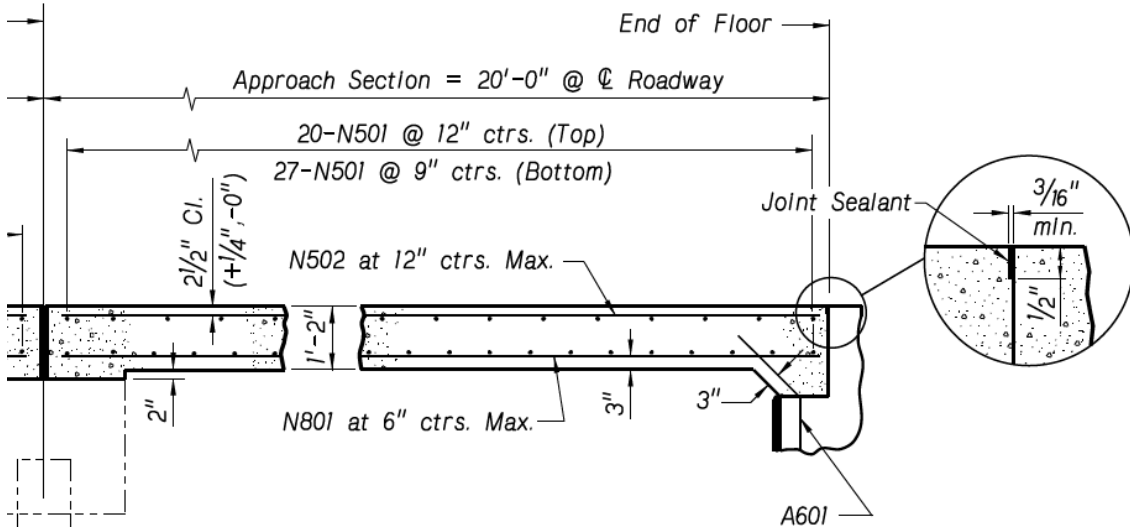
The current practice of CIP concrete approach slabs in US vary among state DOTs with respect to the following parameters: slab length, slab thickness, concrete cover, top and bottom longitudinal and transverse reinforcement, and connections/joints detailing. Below is brief description of these parameters for a selective group of state DOTs.

## 2.2.1. Nebraska

According to NDOT Bridge Office Policies and Procedures (BOPP, 2016), approach slab is designed as one-way slab simply supported by the abutment and the grade beam as shown in Figure 2.2 (BOPP, 2016). The grade beam is a reinforced concrete beam parallel to the abutment, supported by piles to minimize settlement, and extended to cover sidewalk. The minimum span length of approach slab is 20 ft. measured at the centerline of roadway from the end of bridge floor to centerline of grade beam and the minimum thickness is specified as 14 in. The main longitudinal reinforcement is #8 @ 6 in. and #5 @ 12 in. for bottom and top reinforcement, respectively. The transverse reinforcement is #5 @ 12 in. and #5 @ 9 in. for top and bottom reinforcement, respectively. The main longitudinal reinforcement cover is 2.5 in. and 3 in. for top and bottom reinforcement, respectively. The approach slab is anchored to the abutment using #6 bar bent at 45 deg. inside the approach slab with adequate embedment length and cover and spaced at 12 in. The approach slab could be poured separate from the bridge deck or poured continuously with the deck but partially separated using a galvanized plate. Figure 2.2 shows the end of floor detail for each of the two cases. Expansion/contraction joint is placed over the grade beam using joint filler and joint sealant between the approach slab and paving section. Paving section has the same thickness as the approach slab and is anchored to the grade beam using 45 deg. bent bars. It extends for 30 ft to be connected to the roadway pavement using horizontal dowels. Approach slab is resting on a granular backfill and half of the grade beam without a connection, as shown in section B-B, to allow its movement due to temperature changes.







To be used if approach slab is poured continuous with bridge deck.

Stabilize Plate during pour  
ALTERNATE JOINT DETAIL  
AT END OF FLOOR

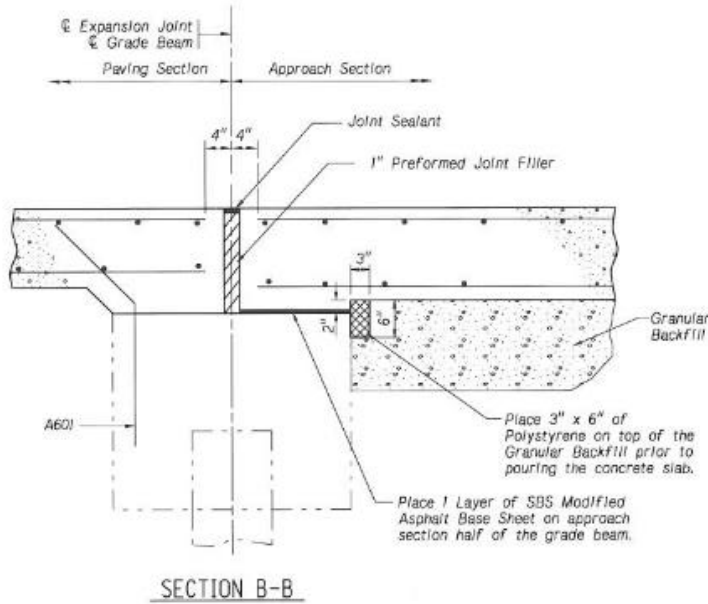


Figure 2.2: NDOT Typical Approach Slab Design and Detailing

## 2.2.2. California

According to Caltrans (2018), different types of CIP concrete approach slabs are available. Figure 2.3 shows only Type N (30) that is 30 ft long and 15 in. thick. Other types of structural approach are: Type R (30), Type R (10), and Type EQ (10). Figure 2.4 shows the different abutment tie details based on movement rating (MR). For MR greater than or equal to 2 in., #5 vertical tie is used at 9 in. spacing. Also, longitudinal reinforcement is used normal to BB and EB lines while transverse reinforcement is always parallel to BB and EB lines.

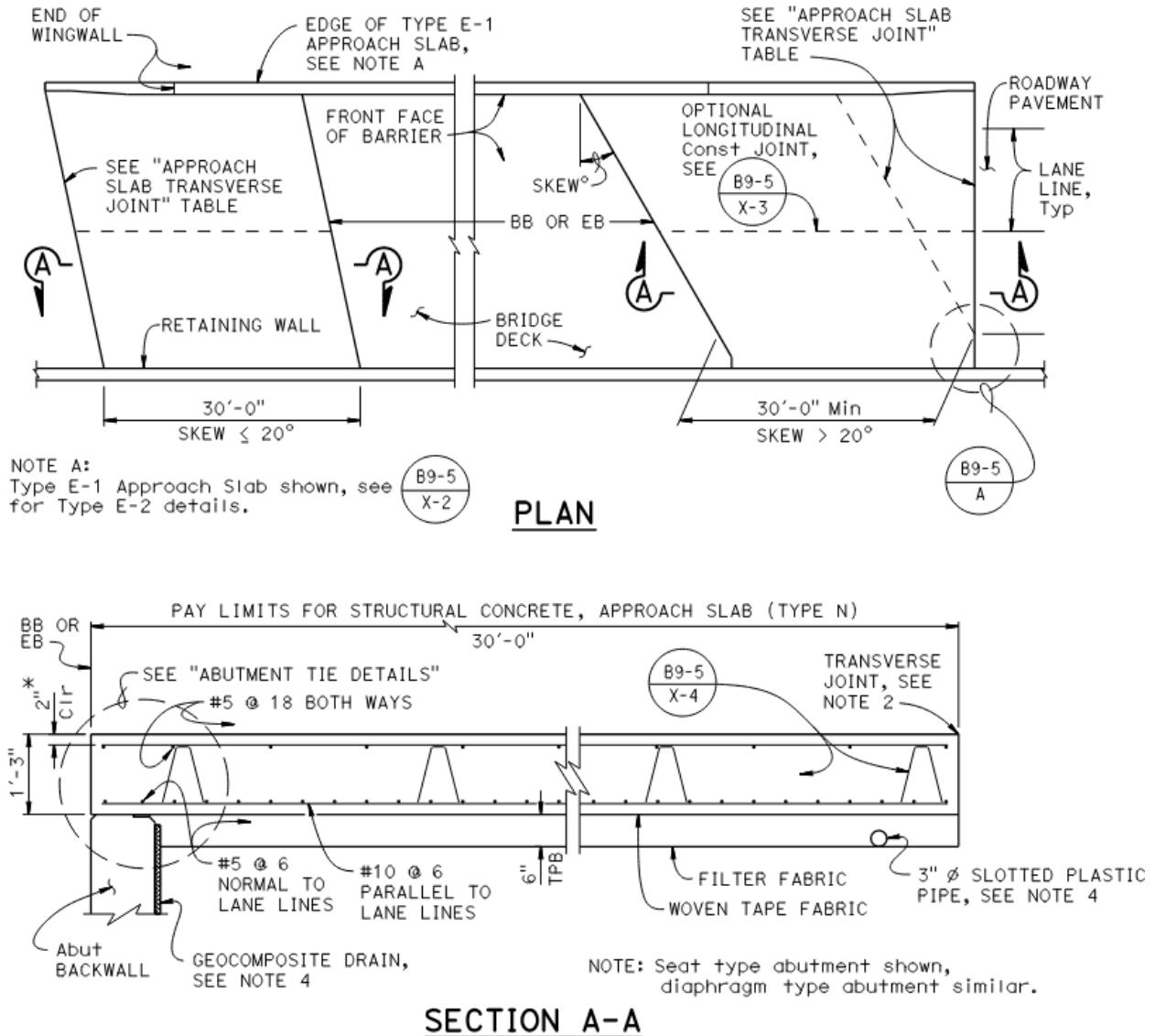


Figure 2.3: Caltrans Typical Approach Slab Design and Detailing

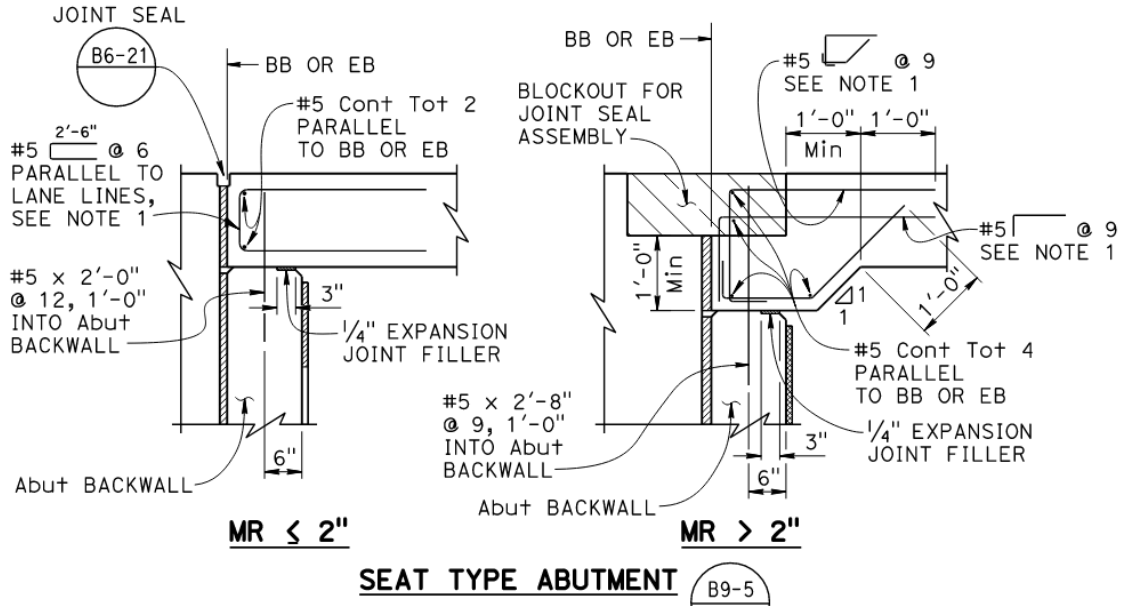
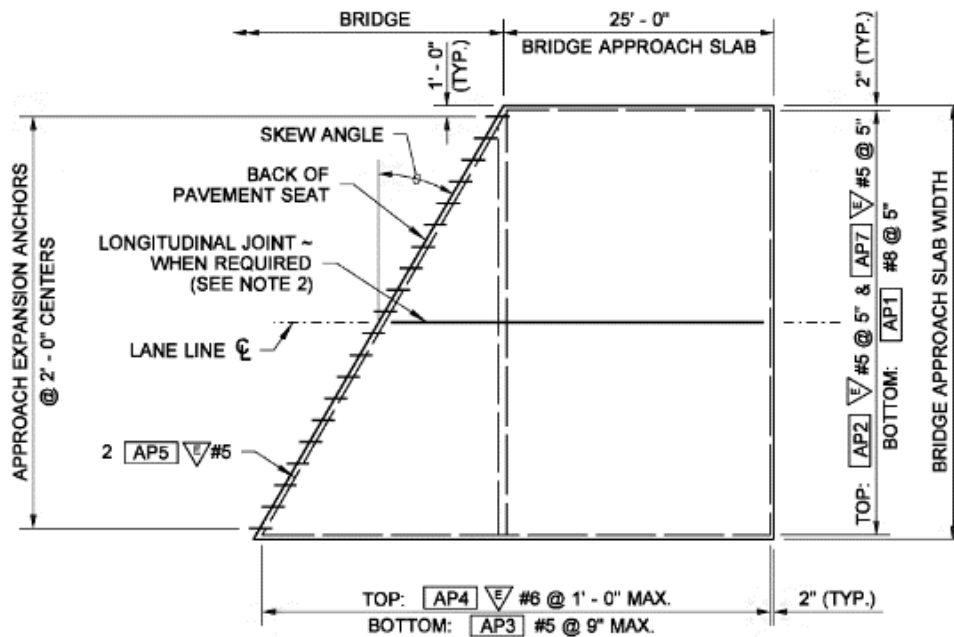


Figure 2.4: Caltrans Abutment tie Details

### 2.2.3. Washington

According to WSDOT (2019), the standard CIP concrete approach slab is 25 ft long and 13 in. thick as shown in Figure 2.5. Dowels are used to connect it to the roadway pavement and 45 deg. bent bars are used to connect it to the abutment. Longitudinal joints are either saw cut at lane lines or full-depth construction joints are used. These joints are required for slabs wider than 40 ft with a maximum section width of 24 ft.



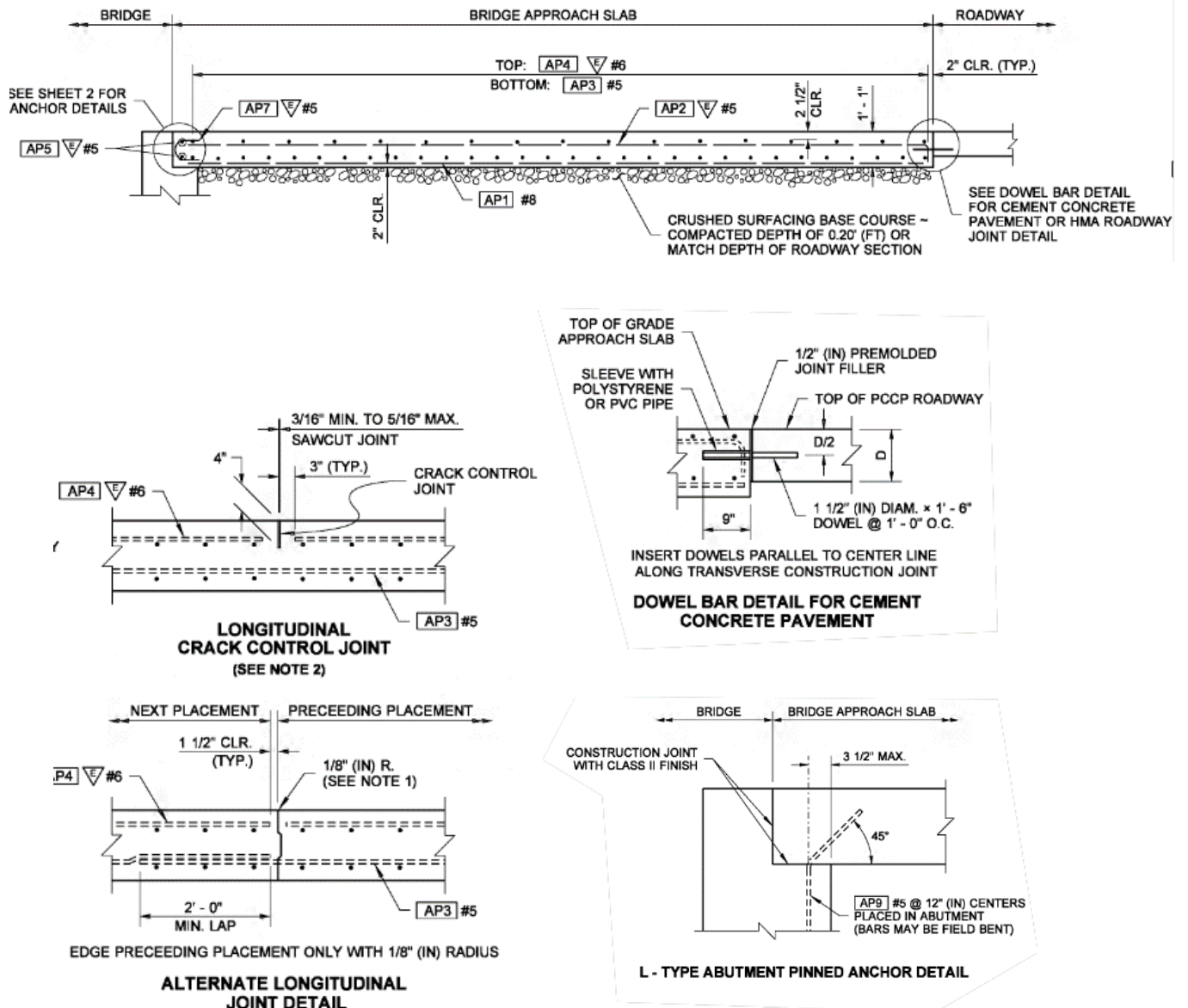


Figure 2.5: WSDOT Approach Slab Design and Detailing

## 2.2.4. Missouri

According to MoDOT (2020), the standard CIP concrete approach slab is 20 ft long and 12 in. thick as shown in Figure 2.6. Approach slab is resting to a 3 ft wide sleeper slab with expansion/contraction joint with the paving section at one end, and 90 deg. bent bar anchors to the abutment at the other end. Approach slabs are poured after and separate from the bridge deck on Type 5 aggregate base. Full-depth keyed construction joints in the approach slab and sleeper slab should be aligned with the construction joint of the bridge deck.

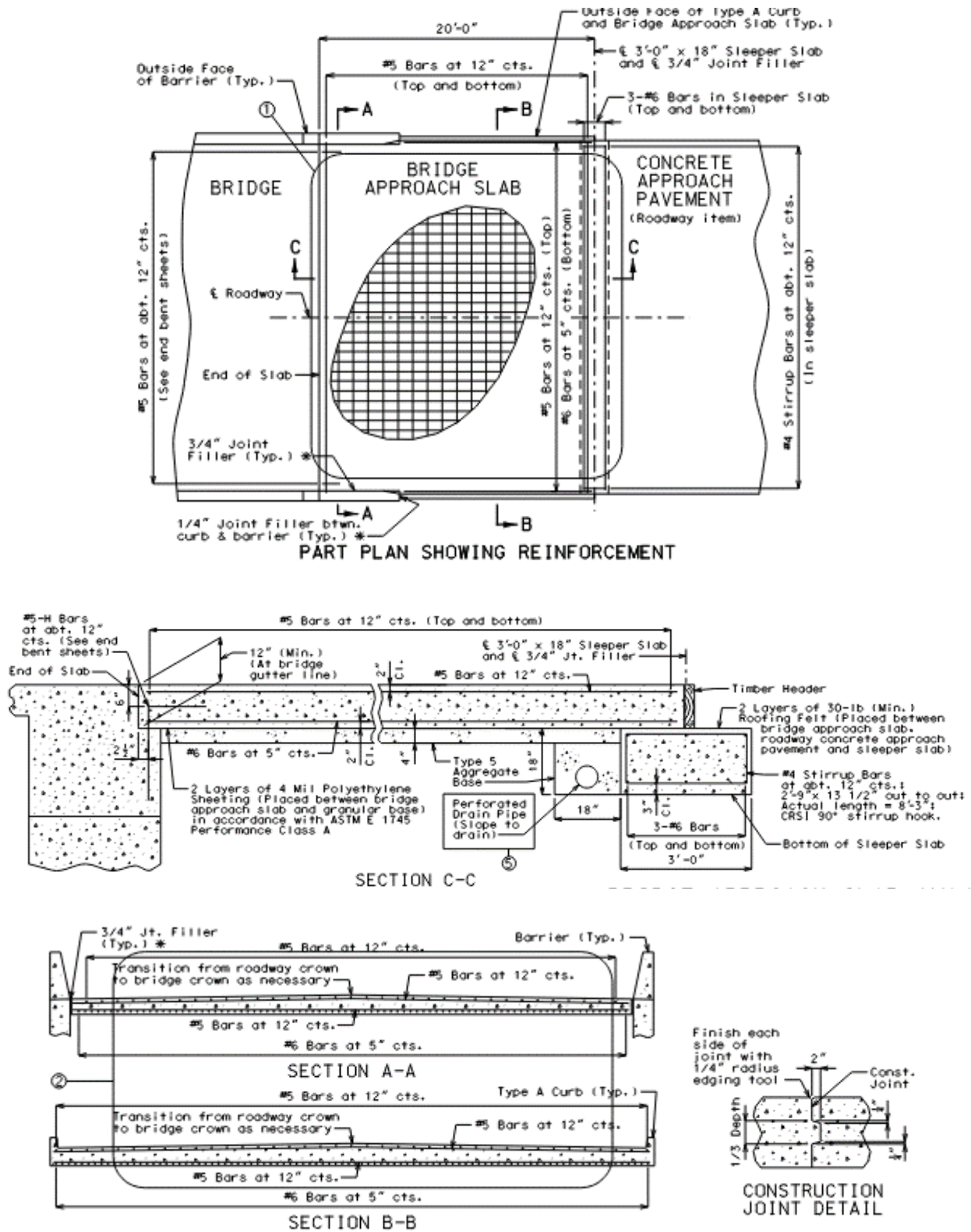


Figure 2.6: MoDOT Approach Slab Design and Detailing

## 2.2.5. Iowa

According to IowaDOT (2020), there are multiple standards for CIP concrete approach slabs with 10 in. and 12 in. thickness, variable and constant depth, singly and doubly reinforced slabs, and for fixed and movable abutments. Figure 2.7 shows the 20 ft long and 12 in. thick constant depth approach slab that is doubly reinforced and connected to single reinforced 20 ft long paving section in case of fixed abutment (top figure), movable abutment (middle figure), and with sleeper slab in case of slab bridges (bottom figure). The figure also shows the pavement lug and wide joint in case of movable abutment.

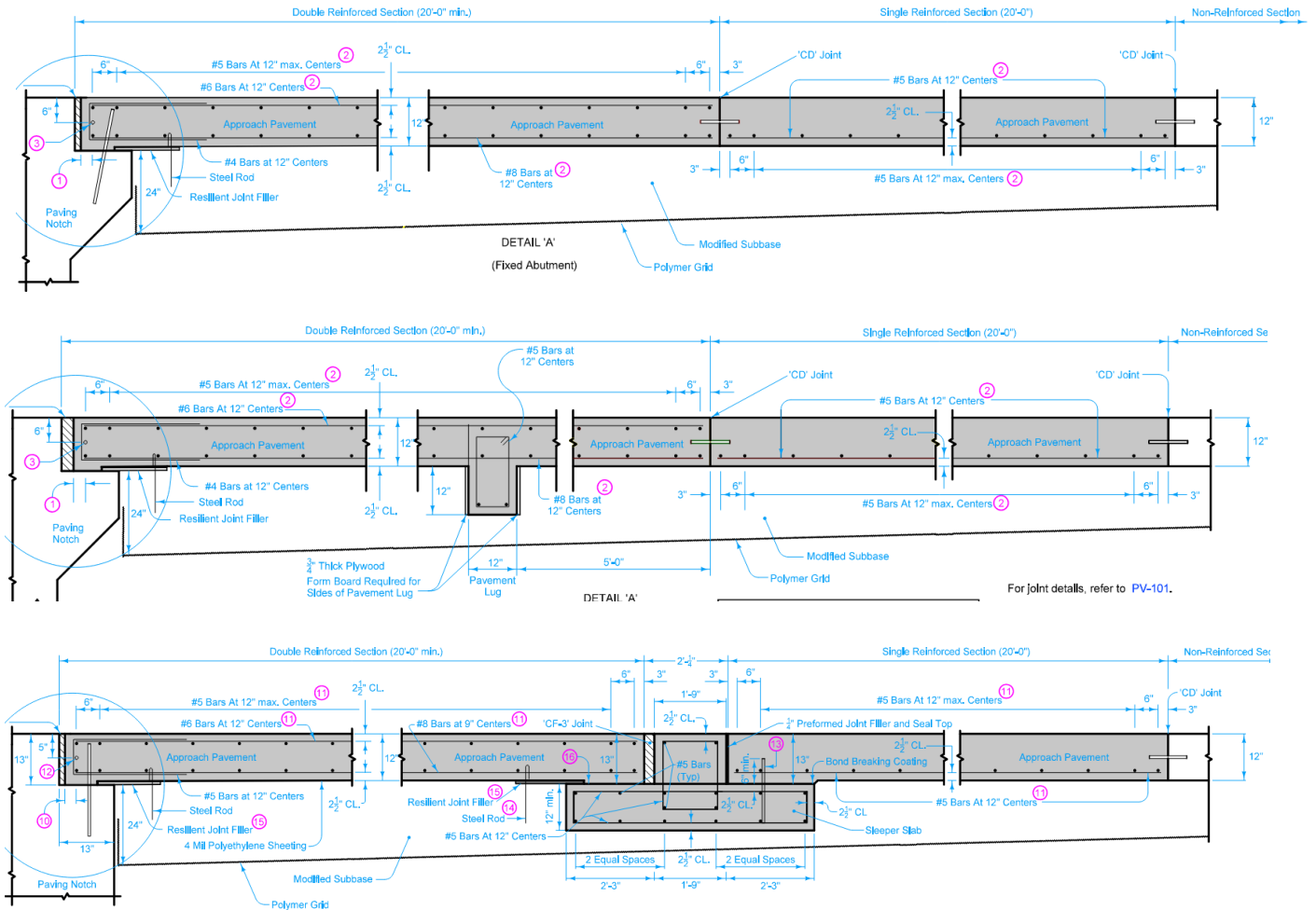


Figure 2.7: IowaDOT Approach Slab Design and Detailing

## 2.2.6. Colorado

According to CDOT (2020), the standard CIP concrete approach slab is 20 ft long and 12 in. thick as shown in Figure 2.8. Approach slab is resting to a sleeper slab with 4 in. wide expansion/contraction joint with the paving section at one end, and 90 deg. bent bar anchors to the abutment at the other end. Longitudinal reinforcement is placed parallel to the centerline of the roadway, while transverse reinforcement is placed

parallel to the abutment support line. When a hot mix asphalt overlay is used, a 2 in. deep saw cut joint filled with sealant is used at the abutment support line.

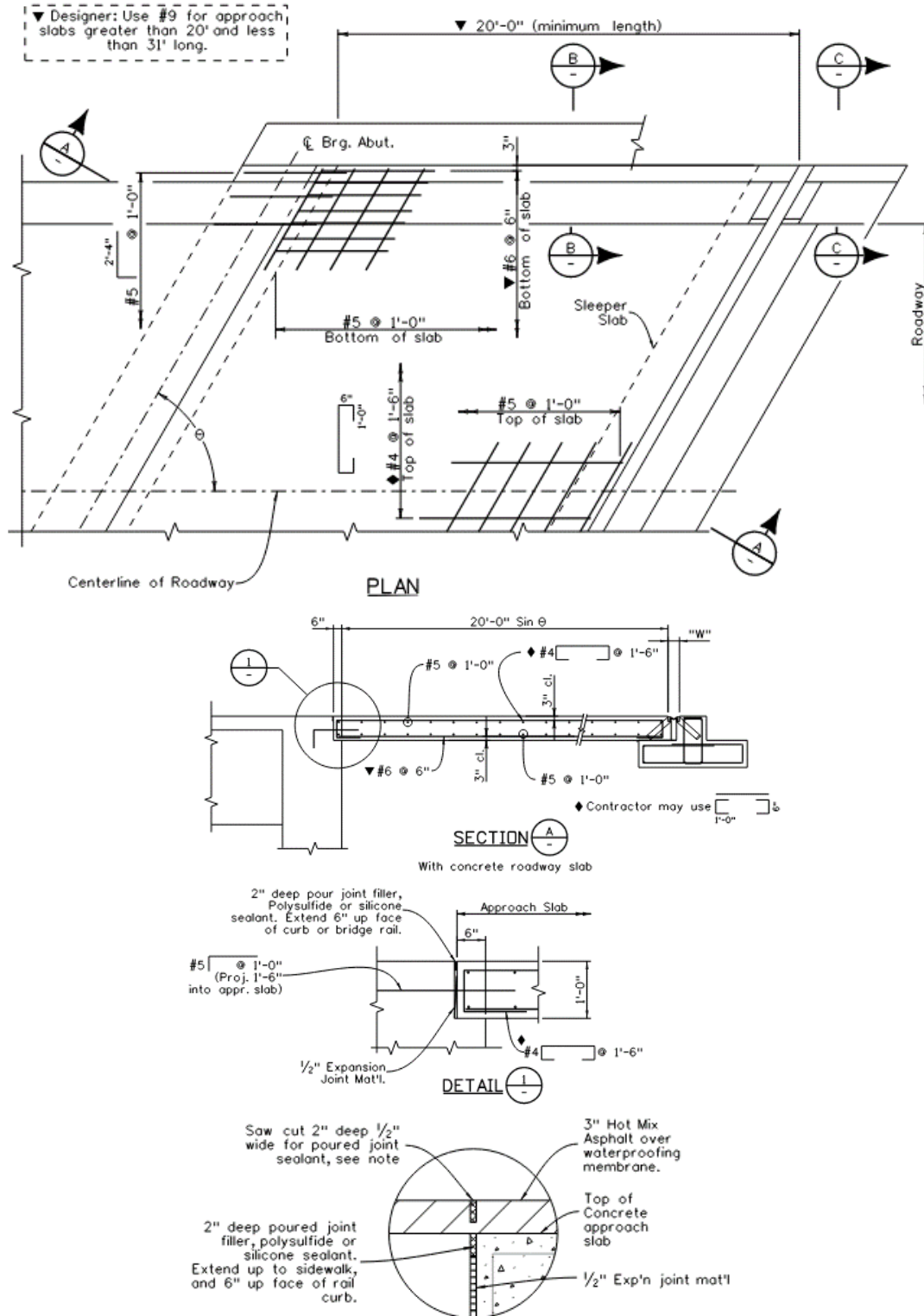


Figure 2.8: CDOT Approach Slab Design and Detailing

Table 1 summarizes the current approach slab detailing for the five different U.S. states presented earlier, which represent different geographic and climatic regions: California Department of Transportation (Caltrans); Washington State Department of Transportation (WSDOT); Missouri Department of Transportation (MoDOT); Iowa Department of Transportation (Iowa DOT); Colorado Department of Transportation (CDOT).

Table 2.1. Summary of approach slab designs

State DOT		Caltrans (Type N 30)	WSDOT	MoDOT	Iowa DOT	CDOT
Span (ft.)		30	25	20	20	20
Slab Thickness (in.)		15	13	12	12	12
Main Longitudinal Reinforcement	Top	#5 @18"	#6@5"	#5@12"	#6@12"	#4 @18"
	Bottom	#10 @6"	#8@5"	#6 @5"	#8 @12"	#6 @6"
Concrete Cover (in.)	Top	2	2.5	2	2.5	3
	Bottom	2	2	2	2.5	3
Transverse Reinforcement	Top	#5@18"	#5 @18"	#5 @12"	#5 @12"	#5 @12"
	Bottom	#5 @6"	#5@9"			
Abutment Edge Joint Type (Figure 2.9)		Vertical #5@9"	45° bent #5@12"	90° bent #5 @ 12"	Vertical Stainless-Steel Dowel	90° bent #5 @ 12"
Other Edge Joint Type		Horizontal #6 dowel @ 12" to paving	Horizontal 1.5 in. dowel @ 18 in. to paving	Resting on Sleeper Slab	Sleeper Slab/ horizontal dowels to paving	Resting on Sleeper Slab

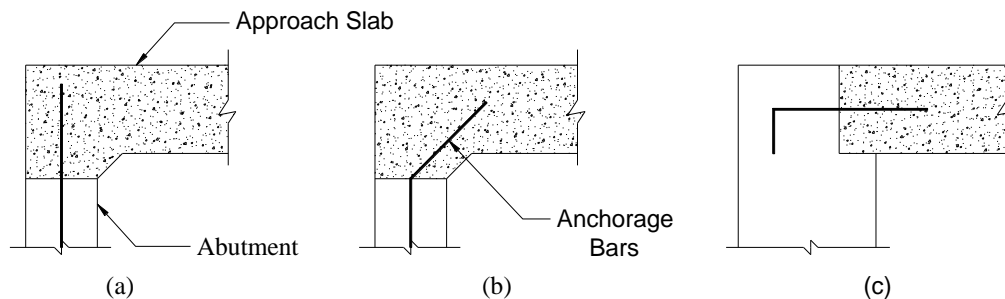


Figure 2.9: Anchorage bar layout in approach slab-abutment connection



### 2.3. Survey Results

Thiagarajan *et.al.* (2010) performed a comprehensive review of approach slab practices in US states DOTs to develop approach slab design and detailing recommendations and perform cost analysis. Table 2.2 summarizes the results of the survey, which include the slab span, depth, bottom and top reinforcement in both longitudinal and transverse directions, cover, and flexural strength. Based on these results, the ranges of different design parameters are as follows:

1. Slab span ranges from 10 ft. to 33 ft.
2. Slab depth ranges from 8 in. to 17 in.
3. Span-to-depth ratio ranges from 10 to 36
4. Bottom longitudinal reinforcement ranges from #5 @ 8 in. to #10 @ 6.5 in.
5. Main reinforcement ratio ranging from 0.3% to 1.4%
6. Bottom transverse reinforcement range from #4 @ 24 in. to #6 @ 6 in.
7. Top longitudinal reinforcement ranges from #4 @ 18 in. to #7 @ 12 in.
8. Top transverse reinforcement ranges from #4 @ 18 in. to #6 @ 12 in.
9. Concrete cover ranges from 1 in. to 4 in.
10. Flexural strength ranges from 16.5 kip.ft to 122.9 kip.ft.

In order to present the results of the survey in a simple and clear manner, Figures 2.10, 2.11, 2.12, and 2.13 are plotted to show the frequency distribution of the following four key design parameters, respectively: span length, slab depth, span-to-depth ratio, and bottom longitudinal reinforcement ratio. These figures also highlight in black-bordered box the range where NDOT approach slab design parameters fall, which indicate that current NDOT approach slab design parameters are not extreme, but rather match the most common ranges used by other states.

Table 2.2 Results of Approach Slab Survey (Thiagarajan et.al., 2010)

State	Span (ft)	Depth (in.)	S/D Ratio	Bottom Long.			Bottom Trans.		Top Long.		Top Trans.		Cover (in.)	ϕ Mn (ft-kip)
				Bar #	Spacing (in.)	Reinf. Ratio	Bar #	Spacing (in.)	Bar #	Spacing (in.)	Bar #	Spacing (in.)		
Alabama	20	9	26.7	6	6	0.8%	4	15	4	4	4	12	3	19.7
Arizona	15	12	15.0	8	9	0.7%	5	12	5	12	5	12	3	36.6
Arkansas	20	9	26.7	5	6	0.6%	4	12					2	17.4
	20	14.5	16.6	7	6	0.7%	5	12	4	18	4	18	2	60.4
California	30	14	25.7	8	6	0.9%	5	12	6	12	5	18	2	73.5
Colorado	20	12	20.0	9	6	1.4%	5	12	5	12	5	12	3	62.7
Connecticut	16	15	12.8	6	6	0.5%	5	12	5	12	5	12	3	43.5
Delaware	18	15	14.4	5	8	0.3%	5	12	5	12	5	12	3	23.7
	30	15	24.0	5	8	0.3%	5	12	5	12	5	12	3	23.7
Florida	30	12	30.0	8	9	0.7%	5	9	5	12	5	12	4	31.9
Georgia	10	10	12.0	7	8	0.8%	5	19	5	12	5	12	1.5	30.0
	30	10	36.0	7	8	0.8%	5	19	5	12	5	12	1.5	30.0
Idaho	20	12	20.0	8	9	0.7%	5	12	4	18	5	12	3	36.6
Illinois	30	15	24.0	9	5	1.3%	5	8	5	12	5	12	2	115.3
Iowa	20	12	20.0	8	12	0.5%	5	12	6	12	5	12	2.5	29.9
Kansas	13	10	15.6	6	6	0.7%	5	18	5	12	5	12	2	27.6
Kentucky	25	17	17.6	8	6	0.8%	5	10					3	87.7
Louisiana	20	12	20.0	6	6	0.6%	4	12	5	12	5	12	3	31.6
Maine	15	8	23.1	6	6	0.9%	5	12	5	12	5	12	1	23.7
Massachusetts	20	10	24.0	7	5	1.2%	4	18	4	9	4	18	3	35.7
Minnesota	20	12	20.0	6	6	0.6%	5	12	5	12	5	12	3	31.6
Mississippi	20	9	26.7	7	12	0.6%	5	24	7	24	5	24	2	16.5
Missouri	25	12	25.0	8	5	1.3%	6	15	7	12	4	18	2	69.2
Missouri Mas	25	12	25.0	6	6	0.6%	4	12	5	12	4	18	2	35.6
<b>Nebraska</b>	<b>20</b>	<b>14</b>	<b>17.1</b>	<b>8</b>	<b>6</b>	<b>0.9%</b>	<b>5</b>	<b>9</b>	<b>5</b>	<b>12</b>	<b>5</b>	<b>12</b>	<b>3</b>	<b>66.4</b>
Nevada	24	12	24.0	7	6	0.8%	4	4	4	12	4	12	3	41.5
New Mexico	14	11	15.3	7	6	0.9%	5	9	4	9	4	9	3.5	33.4
New York	10	12	10.0	5	8	0.3%	5	12	5	8	5	12	3	17.5
North Carolina	25	12	25.0	6	6	0.6%	4	12	5	12	5	12	2	35.6
North Dakota	20	14	17.1	6	6	0.5%	6	6	5	12	5	12	3	39.5
Ohio	15	12	15.0	10	10	1.1%	5	9	5	18	5	18	3	49.8
	20	13	18.5	10	7.5	1.3%	5	8	5	18	5	18	3	72.1
	25	15	20.0	10	7	1.2%	5	8	5	18	5	18	3	95.8
	30	17	21.2	10	6.5	1.1%	5	8.5	5	18	5	18	3	122.9
Oklahoma	20	13	18.5	9	8	1.0%	4	12	4	12	4	12	2.5	59.6
	24	13	22.2	9	8	1.0%	4	12	4	12	4	12	2.5	59.6
	29	13	26.8	9	8	1.0%	4	12	4	12	4	12	2.5	59.6
Oregon	20	12	20.0	7	6	0.8%	6	12	6	12	6	12	2	46.9
	30	14	25.7	9	6	1.2%	6	12	6	12	6	12	2	89.7
Pennsylvania	25	16	18.8	10	9	0.9%	6	12	5	12	5	12	3	84.8
South Carolina	20	12	20.0	9	6	1.4%	5	12	5	12	5	12	3	62.7
South Dakota	20	9	26.7	6	6	0.8%	6	6	5	12	5	12	3	19.7
Tennessee	24	12	24.0	6	6	0.6%	4	18	5	12	5	12	2	35.6
Texas	20	13	18.5	8	6	1.0%	5	12	5	12	5	12	3	59.3
Vermont	15	14	12.9	6	6	0.5%	5	12					3	39.5
	20	15	16.0	9	10	0.7%	5	12					3	57.0
	25	16	18.8	9	9	0.7%	5	12					3	68.7
Virginia	20	15	16.0	7	6	0.7%	5	9	5	12	5	18	3.5	55.0
	22	15	17.6	8	6	0.9%	5	9	5	12	5	18	3.5	70.0
	25	15	20.0	8	6	0.9%	5	9	5	12	5	18	3.5	70.0
	28	15	22.4	9	6	1.1%	5	9	6	12	5	18	3.5	85.2
Washington	25	13	23.1	8	5	1.2%	5	9	6	5	5	18	2	77.7
Wisconsin	16	12	16.0	6	6	0.6%	4	24	5	12	5	12	2	35.6
Wyoming	33	12	33.0	5	8	0.3%	5	12	5	12	5	12	3	17.5
<b>MIN.</b>	<b>10</b>	<b>8</b>	<b>10</b>	<b>5</b>	<b>5</b>	<b>0.3%</b>	<b>4</b>	<b>4</b>	<b>4</b>	<b>4</b>	<b>4</b>	<b>9</b>	<b>1</b>	<b>16.5</b>
<b>MAX.</b>	<b>33</b>	<b>17</b>	<b>36</b>	<b>10</b>	<b>12</b>	<b>1.4%</b>	<b>6</b>	<b>24</b>	<b>7</b>	<b>24</b>	<b>6</b>	<b>24</b>	<b>4</b>	<b>122.9</b>

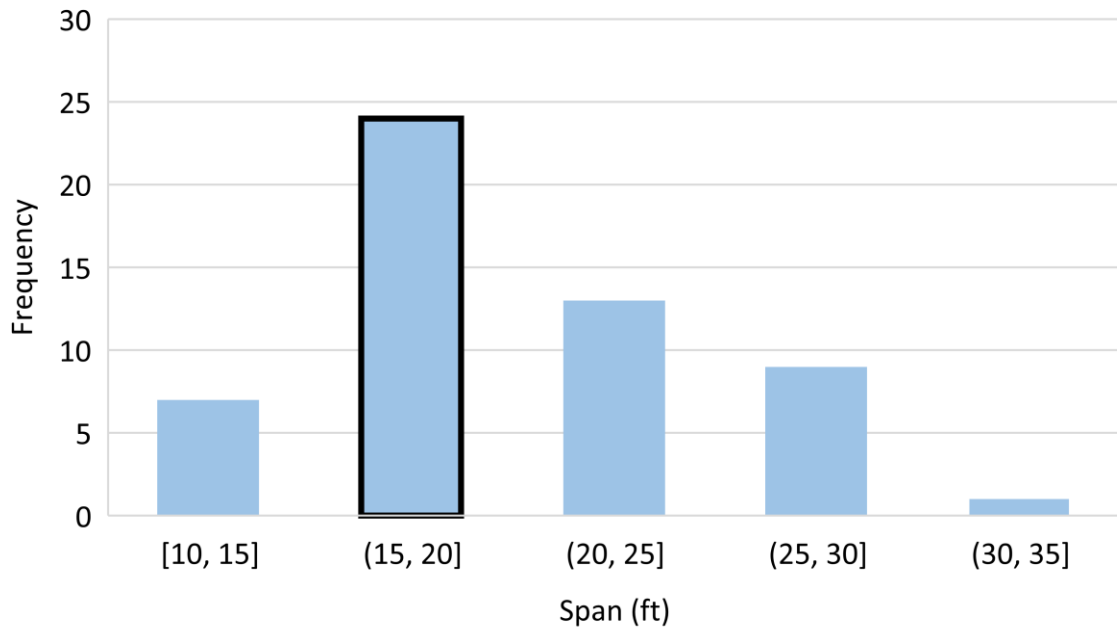


Figure 2.10: Span length frequency distribution

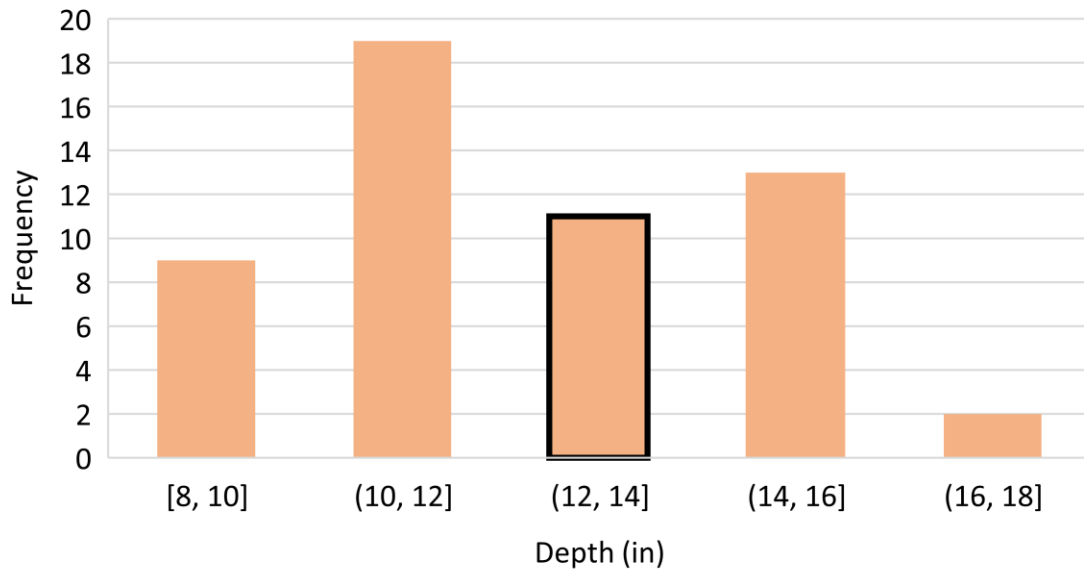


Figure 2.11: Slab depth frequency distribution

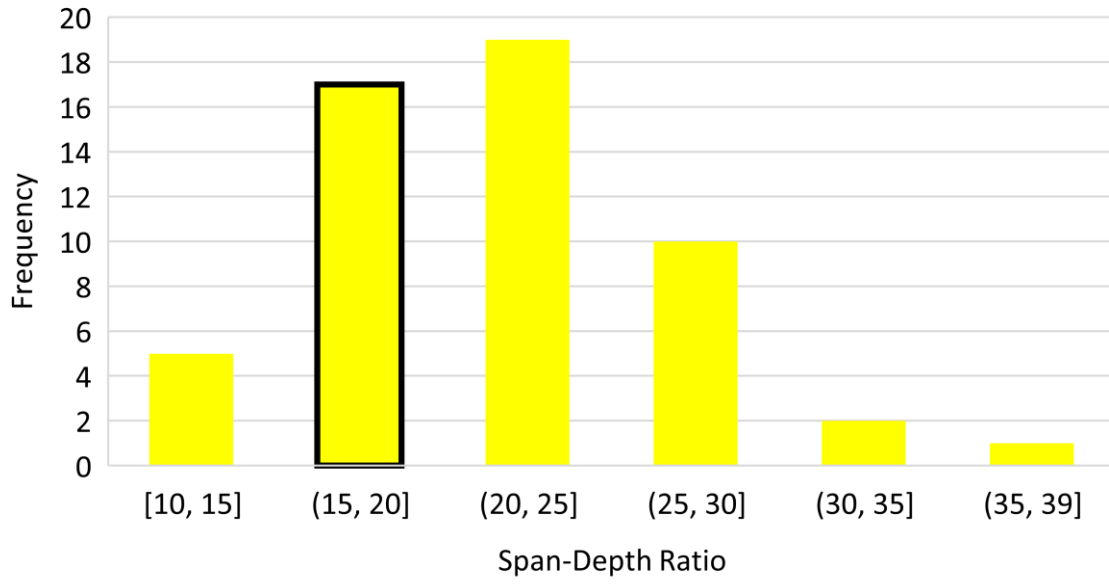


Figure 2.12: Span-to-depth ratio frequency distribution

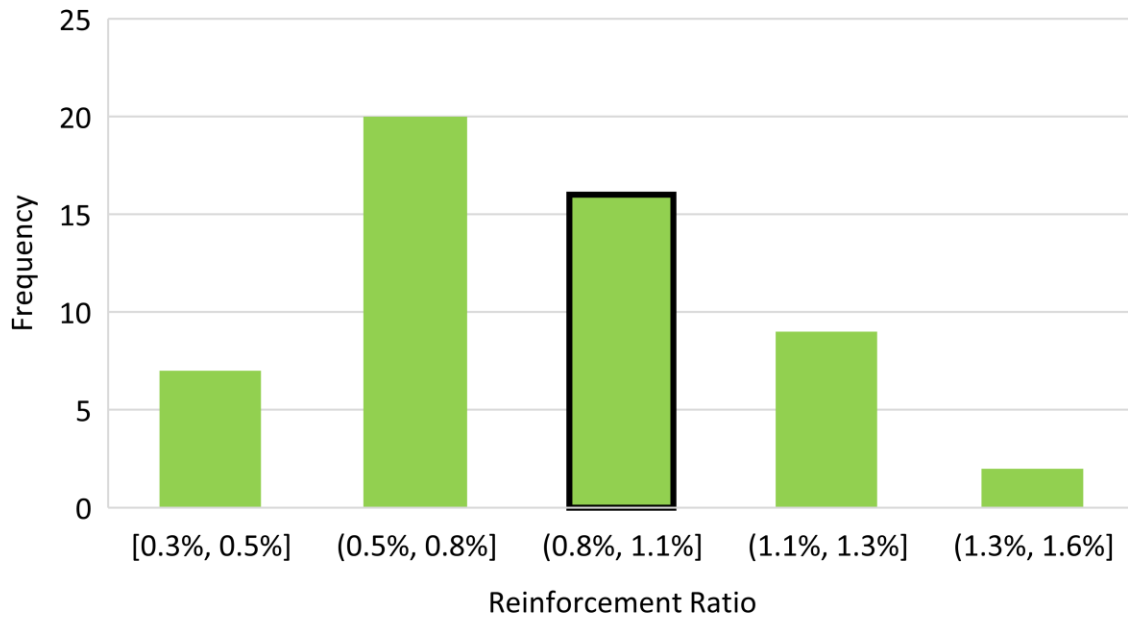


Figure 2.13: Reinforcement ratio frequency distribution

Chee, (2018) conducted a survey for state DOTs about the general design and construction practices for integral abutment bridges and the performance of approach slabs in these bridges compared to conventional bridges. The purpose of the survey was to identify the parameters that might contribute to approach slab deterioration, in general, and cracking in particular. Twenty-three states responded to the survey, most of them are Midwest states. Figure 2.14 shows the type of problem that was identified by the states as a primary problem in approach slabs. This plot indicates that approximately 50% of the states identified cracking as the primary problem, which is second to settlement. Figure 2.15 plots the type/direction of the observed cracking. This plot indicates that longitudinal cracks are the most dominant type of cracking in approach slabs. According to the survey results, the following are the different method suggested by states to minimize the cracking in approach slabs:

1. Increase reinforcement (most common)
2. Increase thickness
3. Limit skew angle to 45°
4. Design as simply supported slab
5. Adjust concrete mix and wet curing process
6. Saw cut along lane lines
7. Cast as individual sections
8. Restrict slab length

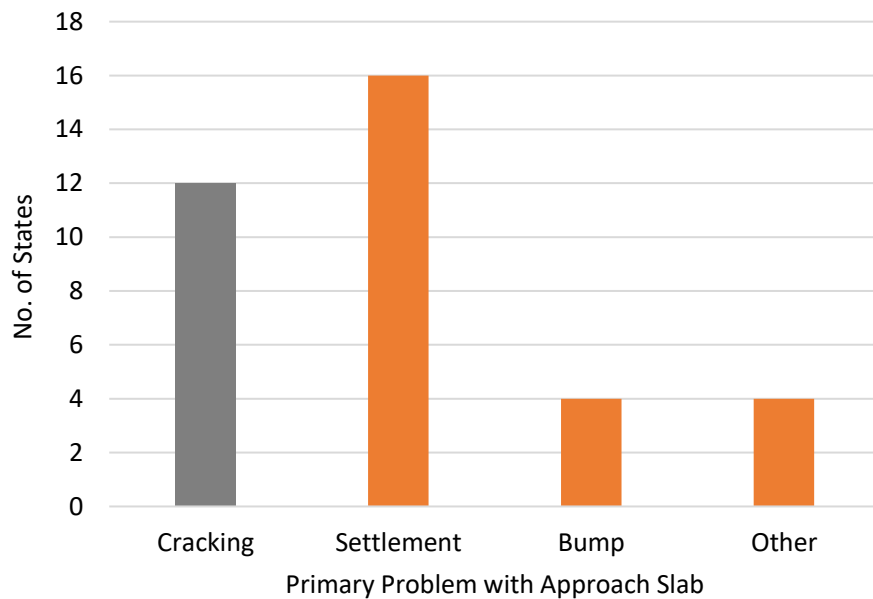


Figure 2.14: Distribution of approach slab primary problems

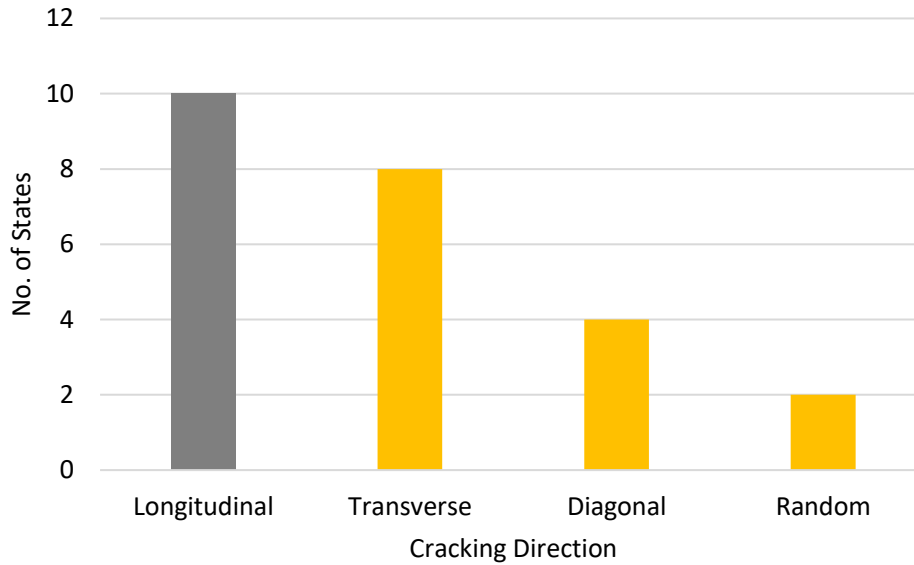


Figure 2.15: Distribution of approach slab cracking directions

This survey also included questions regarding the material used underneath the approach slabs to reduce soil friction and type of support used at the paving end. Figure 2.16 and Figure 2.17 show the answers to these two questions respectively. Figure 2.23 indicates that about 43% of the surveyed states use a certain method to reduce the friction with the soil, primarily polyethylene sheeting. Figure 2.24 indicates that sleeper slab is the most common type of support for approach slab at the paving end. More information about other details, such as connection at the abutment end, can be found in the reference Chee, (2018)

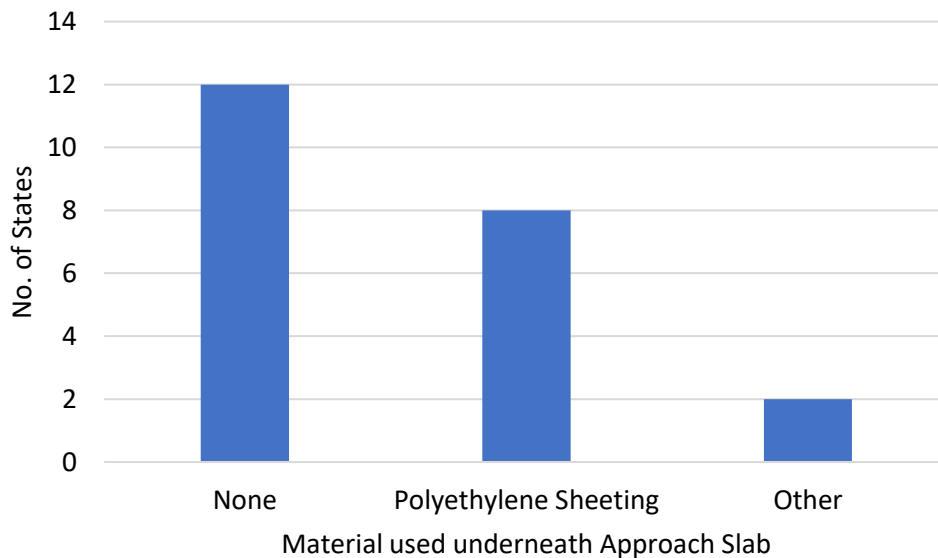
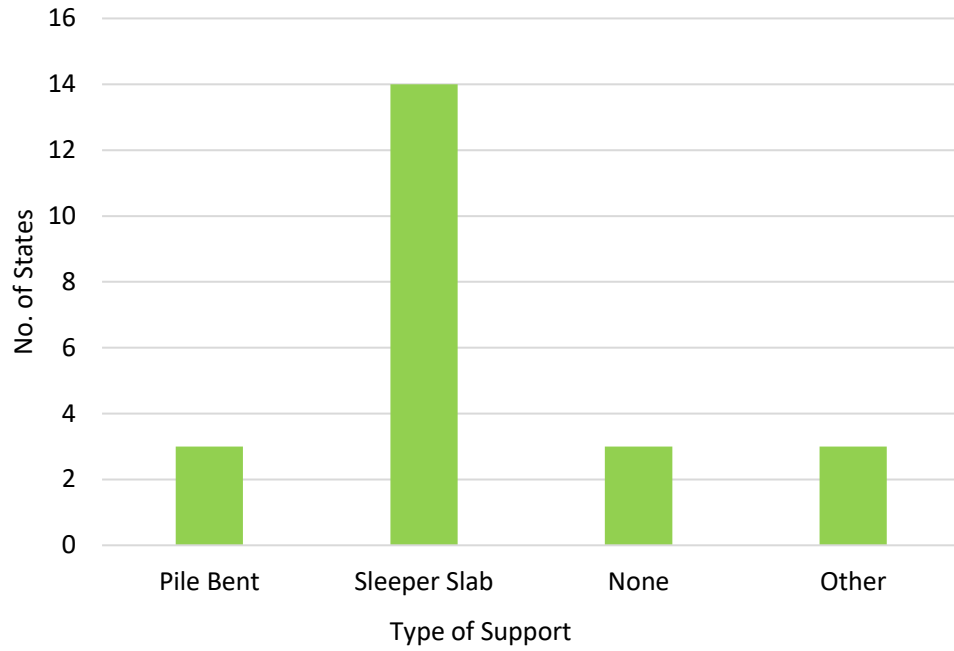


Figure 2.16: Distribution of the material used underneath approach slabs



*Figure 2.17: Distribution of approach slab type of support at pavement end*

# Chapter 3. Condition Evaluation

## 3.1 Field Observations

Three field visits were conducted on October 2, 2020 to visually inspect approach slabs and assess the level of cracking. This is in addition to the data obtained from routine visual inspection of bridges obtained from NDOT, which are presented in the next section. The three selected bridge had different conditions with respect to approach slab detailing, skew angle, and traffic volume to evaluate the effect of these conditions on the cracking pattern and intensity. Below are description of each of the three bridges, map of approach slab and paving section cracking, and photos of their cracking.

### Ayr Bridge on Little Blue River

This is a three-span steel girder bridge in Ayr, Adams County, NE over Little Blue River. The bridge was redecked in 2014 with a new approach slab and paving section. The bridge has 35 degree skew and roadway width of 30 ft, as shown in Figure 3.1, and an Average Daily Traffic (ADT) of 440. The unique feature of this bridge is the connection of the paving section to the grade beam, which had a 3 in. x 3 in. x 3 in. polysterene block around the #6 dowel bar as shown in Figure 3.2. This was provided to reduce stress concentration at the connection and, consequently, minimize cracking due to volume changes. However, the observed crackign shown in Figure 3.3 for the bridge deck, approach slab, and paving section indicates that there are several cracks that are primarily longitudinal and perpendicular to the support lines. The intensity and extent of these cracking is evident in the photos shown in Figure 3.4. This cracking could be attributed to the high skew angle and restrained skrinkage of the slabs in the transverse direction, which will be analytically investigated in the next chapter.

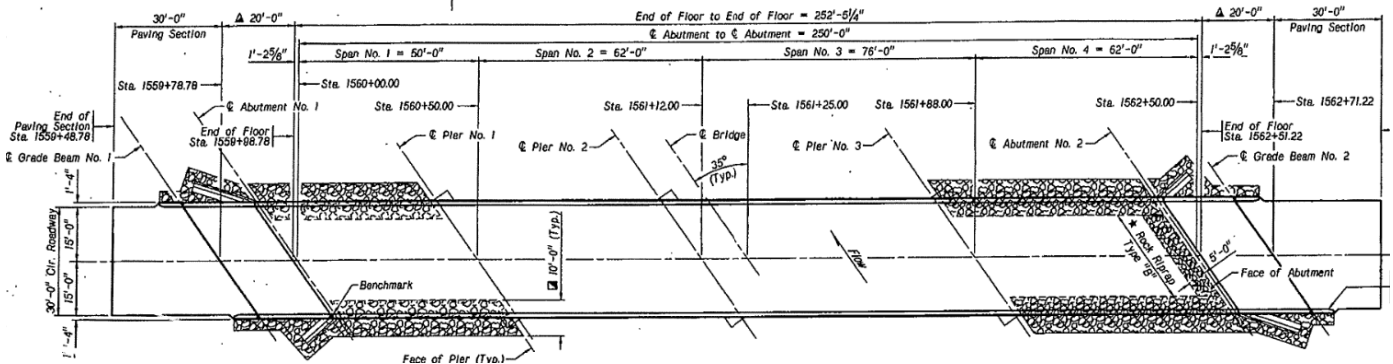


Figure 3.1: Plan view of Ayr Bridge



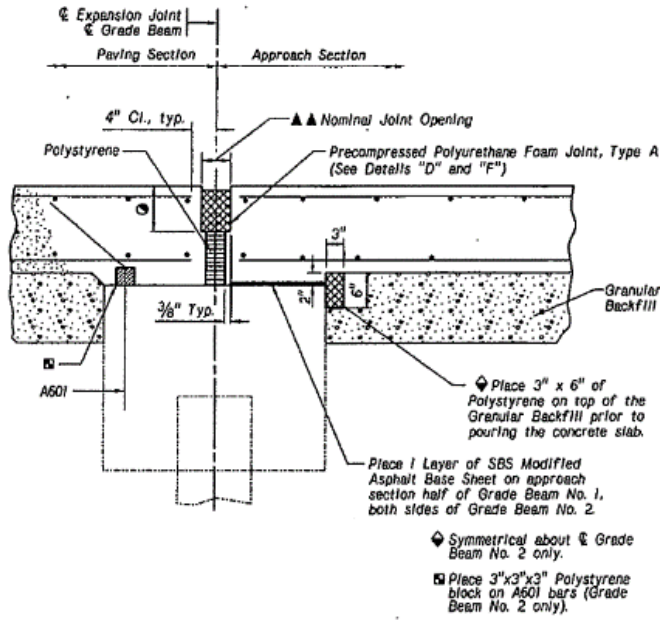


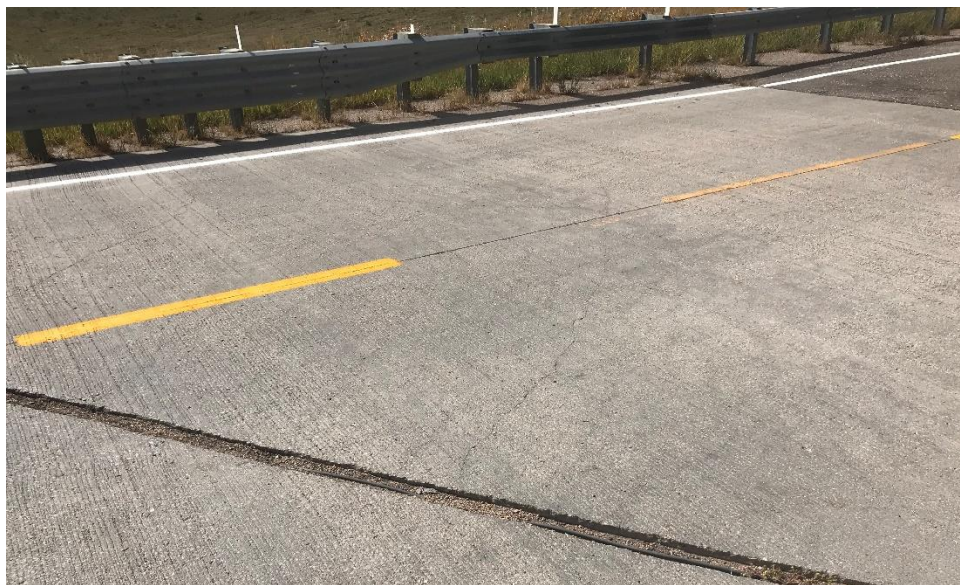
Figure 3.2: Ayr bridge connection detail at the grade beam



Figure 3.3: Ayr bridge cracking map



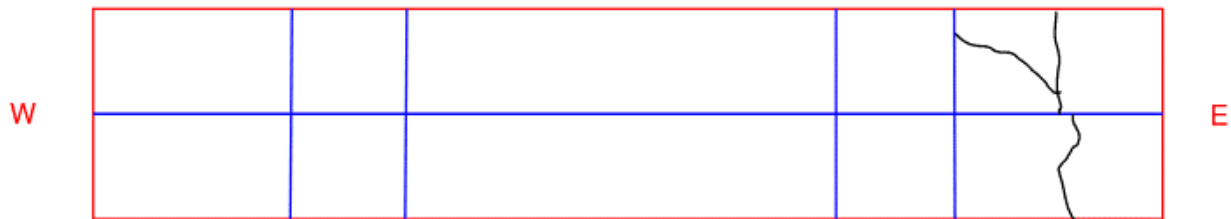




*Figure 3.4: Ayr bridge approach slab and paving section cracking*

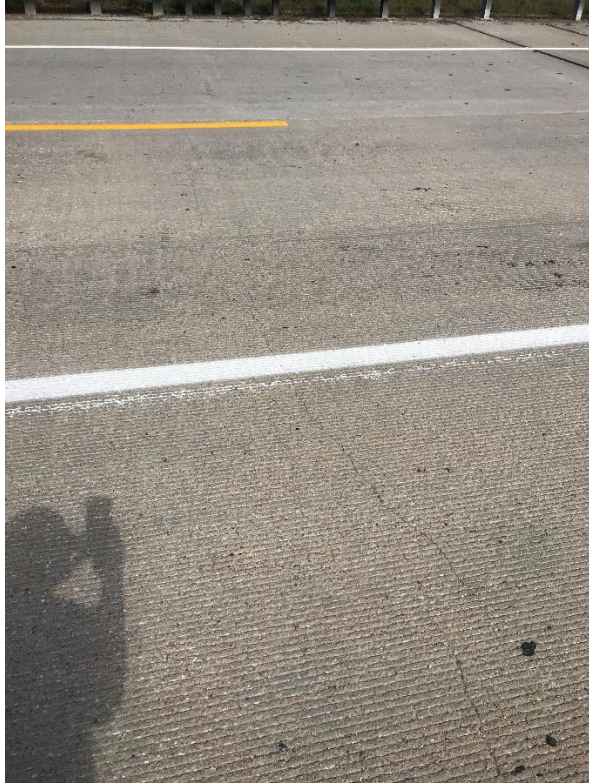
### Little Sandy Creek Bridge on I-74 E

This is a three-span concrete girder bridge on I-74E over Little Sandy Creek in Adams County, NE. The bridge has no skew and had only transverse cracks in the paving section as shown in Figure 3.5. This could be attributed to the relative settlement between the grade beam end and roadway end. The photos shown in Figure 3.6 indicate that no cracking was observed in the approach slabs, which could be as result of having no skew in addition to low traffic volume.



*Figure 3.5: Cracking map of approach slab and paving section of Little Sandy Creek bridge.*





*Figure 3.6: Little Sandy Creek bridge approach slab and paving section cracking*

## Turkey Creek Bridge on US 81

This is a three-span prestressed concrete Tee girder bridge on US 81 over Turkey Creek in Furnas County, NE. The bridge was built in 2001 and has 15 degrees skew and roadway width of 38.4 ft. The bridge has an ADT of 6540 with 22% truck traffic. Figure 3.7 shows the cracking map of the approach slab and paving section indicating minor longitudinal cracking in the approach slab and significant transverse cracking of the paving section, which could be attributed to the relative settlement between the grade beam end and roadway end. Figure 3.8 shows photos of these cracks as well as deterioration at the expansion joint.



*Figure 3.7: Cracking map of approach slab and paving section of Turkey Creek bridge*





*Figure 3.8: Turkey Creek bridge approach slab and paving section cracking*

## Other Bridges

Figure 3.9 shows the cracking patterns observed in several bridge approach slabs during the routine visual inspections. Structure number and year of inspection are provided below each photo.



SS66C00220\_Y15





S275\_06764L\_Y15



S275\_06761\_Y11



S275\_06761\_Y11



S080\_42831R\_Y12



S080\_42831R\_Y12



S034\_31644\_Y15



S034\_31644\_Y15



S034\_31644\_Y11



S080\_42770L\_Y14

*Figure 3.9: Photos of approach slab and paving section cracking at different bridges*

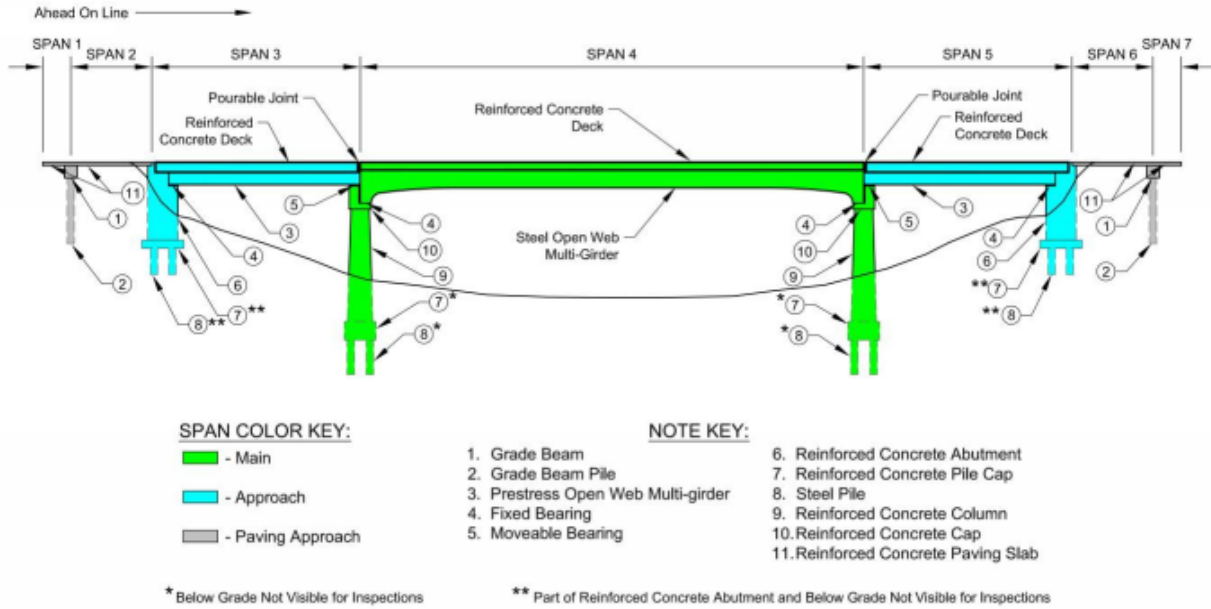
### 3.2 Inspection Records

National Bridge Inspection Standards (NBIS) were established in the 1970s to collect condition ratings and other functional and geometric data (National Bridge Inventory (NBI) data) for bridges to calculate the Sufficiency Rating for funding prioritization. These NBI condition ratings are determined for main bridge components (superstructure, substructure, deck and culverts) through biannual visual inspections. Based on these inspections, the condition of approach slabs and their deterioration cannot be determined. Since 2014, NDOT has been gathering Element Inspection (EI) data, which is detailed data that allows them to manage their bridge inventory more effectively by (NDOT, 2018):

- Quantifying and describing element condition observed during inspection and the extent of deterioration.
- Identifying candidates for preservation, maintenance, rehabilitation, improvement (i.e. widening, raising, strengthening) and replacement practices/strategies.
- Predicting future deterioration of bridge elements for schedule purposes.
- Managing their budgets for bridge preservation.




Therefore, EI data was gathered and analyzed to assess the deterioration of approach slabs and determine the effect of governing parameters, such as age, skew angle, average daily traffic, and percentage of truck traffic, on their deterioration. These data was obtained from NDOT bridge office during the summer of 2020.

Figure 3.10 presents the bridge elements of the paving, approach, and main spans. Element number 321 represents Reinforced Concrete Paving Slab, which is defined as the reinforced concrete slabs immediately adjacent to the bridge structure and connected to the roadway. When the approach slab spans between the bridge abutment and a grade beam, this element also includes the paving slab beyond the approach slab. Rating is conducted in square foot of the slab in each condition state. Figure 3.11 shows the definitions of each condition state for each type of defects. Since cracking is the major concern in concrete approach slabs, defect number 1130 is considered in this study to determine the intensity and extent of cracking. The assessment should represent the worst condition stated in each square foot, which includes only the top of the approach slab. If an overlay is present, destructive or nondestructive testing or indicators in the overlay are used to assess the condition of the approach slab that is not visible.



Span Unit Type	Span Unit Number	Element Number
Main	1	12 - R/C Deck (Span 4)
Main	1	301 - Pourable Joint Seal (x2) (Span 4)
Main	1	107 - Steel Open Girder/Beam (Span 4)
Main	1	9304 - Fix Plate Bearing (x2) (Span 4)
Main	1	205 - R/C Column (x2) (Span 4)
Main	1	234 - R/C Pier Cap (x2) (Span 4)
Approach	2	12 - R/C Deck (x2) (Span 3 & 5)
Approach	2	109 - Prestressed Concrete Open Girder/Beam (x2) (Span 3 & 5)
Approach	2	9304 - Fix Plate Bearing (x2) (Span 3 & 5)
Approach	2	9228 - Roller Bearing (x2) (Span 3 & 5)
Approach	2	215 - R/C Abutment (x2) (Span 3 & 5)
Paving	3	321 - R/C Paving Slab (x4) (Span 1, 2, 6 & 7)
Paving	3	9230 - Grade Beam Cap (x2) (Span 1, 2, 6 & 7)
Paving	3	9234 - R/C Grade Beam Pile (x2) (Span 1, 2, 6 & 7)

Figure 3.10: Bridge paving, approach, and main spans as well as their elements

Defects	Condition States			
	1	2	3	4
	GOOD	FAIR	POOR	SEVERE
Delamination/ Spall/ Patched Area (1080)	None.	Delaminated. Spall 1 in. or less deep or 6 in. or less in diameter. Patched Area that is sound.	Spall greater than 1 in. deep or greater than 6 in. diameter. Patched Area that is unsound or showing distress. Does not warrant structural review.	The condition warrants a structural review to determine the effect on strength or serviceability of the element or bridge; OR a structural review has been completed and the defects impact strength or serviceability of the element or bridge.
Exposed Rebar (1090)	None.	Present without measurable section loss.	Present with measurable section loss but does not warrant structural review.	
Efflorescence/ Rust Staining (1120)	None.	Surface white without build-up or leaching without rust staining.	Heavy build-up with rust staining.	
	*			
Cracking (RC and Other) (1130)	Width less than 0.012 in. or spacing greater than 3.0 ft.	Width 0.012 in. to 0.05 in. or spacing of 1.0 ft. to 3.0 ft.	Width greater than 0.05 in. or spacing of less than 1 ft.	The condition warrants a structural review to determine the effect on strength or serviceability of the element or bridge; OR a structural review has been completed and the defects impact strength or serviceability of the element or bridge.
Abrasion/Wear (PSC/RC) (1190)	No abrasion or wearing.	Abrasion or wearing has exposed coarse aggregate but the aggregate remains secure in the concrete.	Coarse aggregate is loose or has popped out of the concrete matrix due to abrasion or wear.	
Damage (7000)	Not applicable.	The element has impact damage. The specific damage caused by the impact has been captured in Condition State 2 under the appropriate material defect entry.	The element has impact damage. The specific damage caused by the impact has been captured in Condition State 3 under the appropriate material defect entry.	The element has impact damage. The specific damage caused by the impact has been captured in Condition State 4 under the appropriate material defect entry.

\*Note: Photos approximate the boundary condition between Good/Fair, Fair/Poor and Poor/Severe.

Figure 3.11: Definitions of condition ratings for different element defects

Figures 3.12, 3.13, 3.14, and 3.15 show the frequency distribution of age, skew angle, roadway clear width, and traffic volume (ADT and % truck), respectively, for NDOT approach slab elements considered in this study, which were approximately 500 elements. These parameters were determined based on the literature review and several studies contributed the cracking to one or more of these parameters. Figures 3.16, 3.17, 3.18, 3.19, and 3.20 show the relationships between

each of these governing parameters and the percentage of approach slab area that is cracked including all those in the four condition states. These plots indicate that there is no strong relationship between the % cracked area and any of these governing parameters. However, age appears to be the parameter that has the highest direct correlation as more cracking is observed in older approach slabs than newer ones.

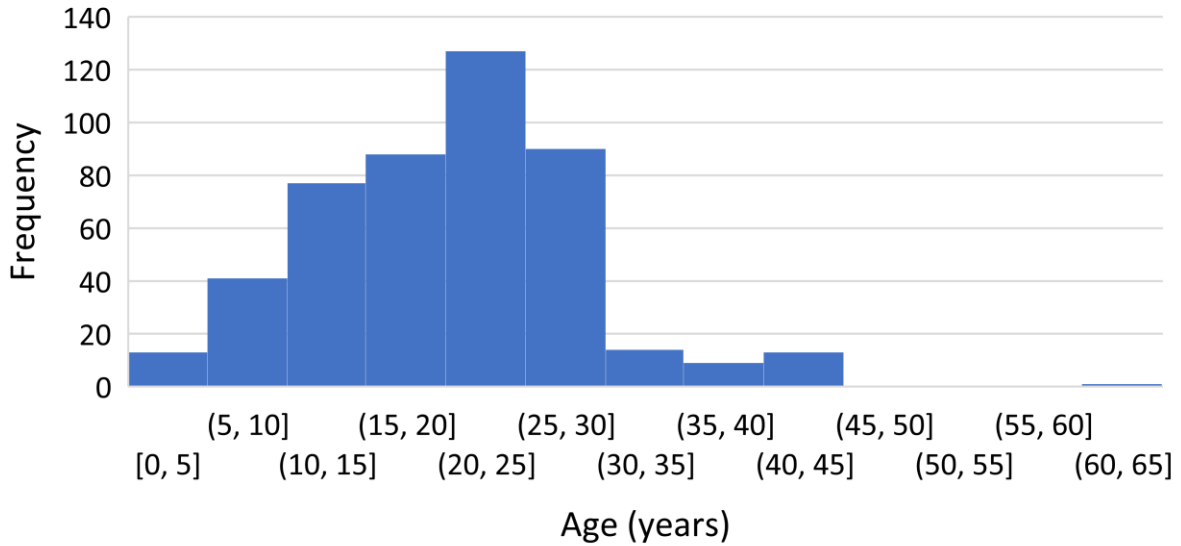


Figure 3.12: Frequency distribution of age of the considered NDOT approach slabs

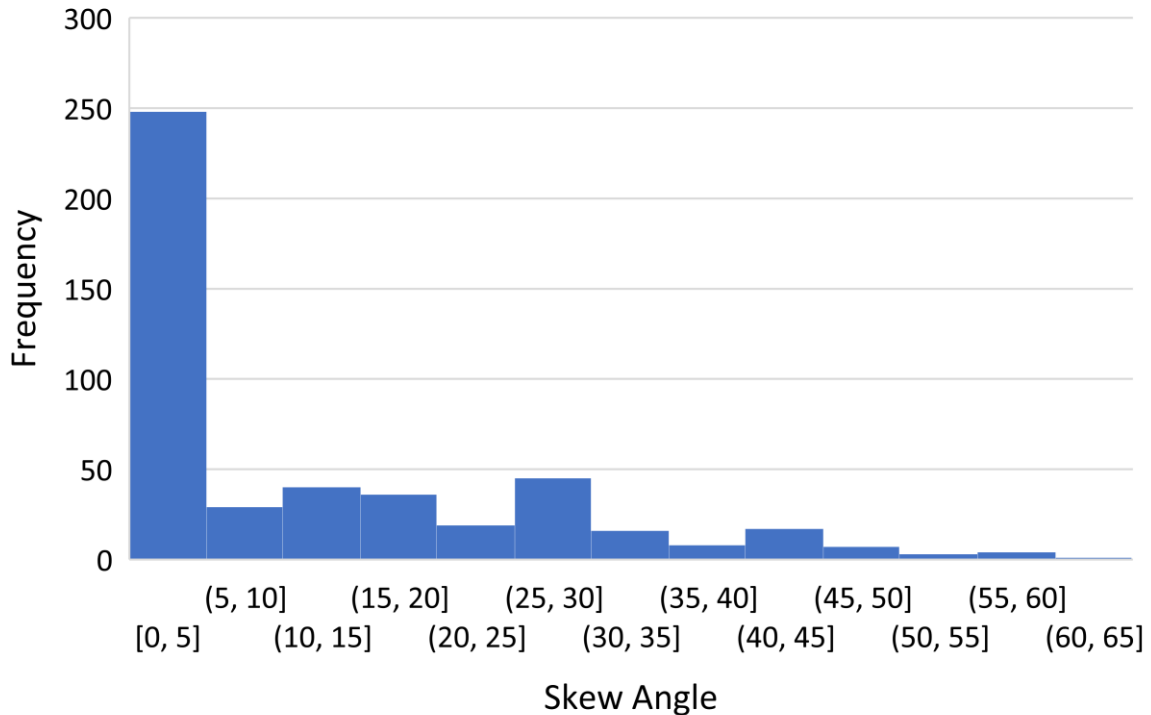


Figure 3.13: Frequency distribution of skew angle of the considered NDOT approach slabs



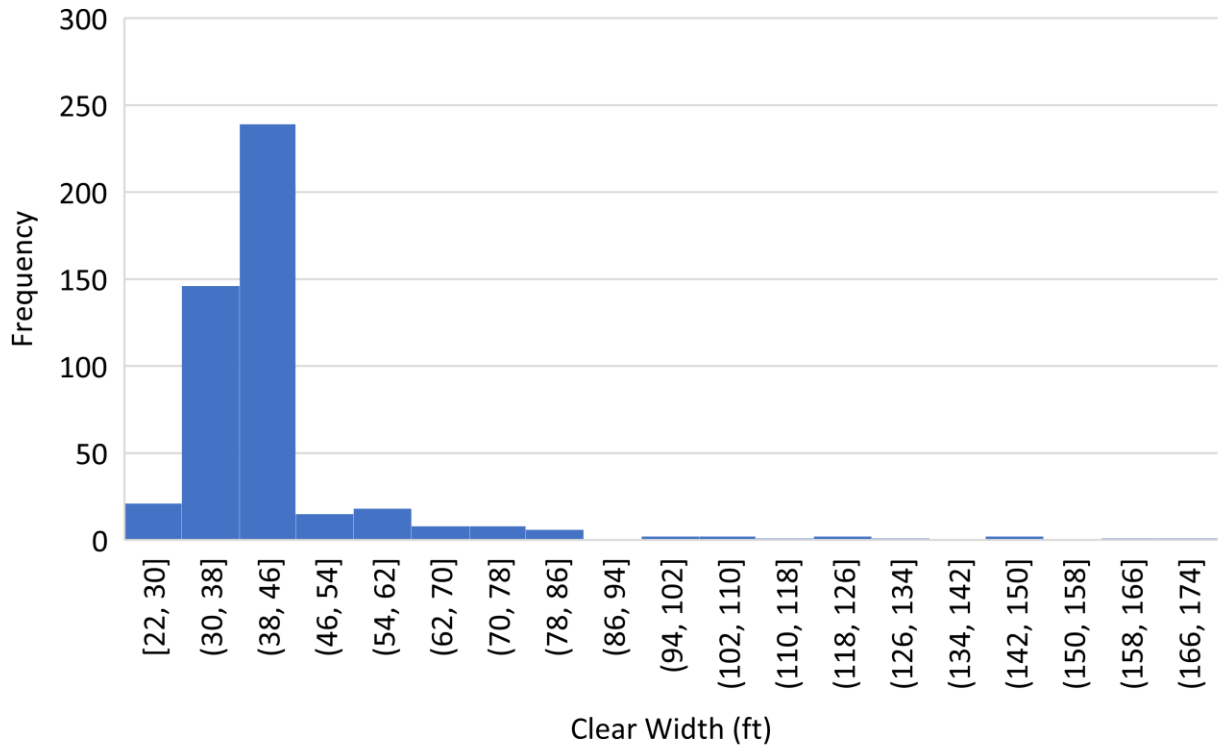


Figure 3.14: Frequency distribution of roadway clean width of the considered NDOT approach slabs

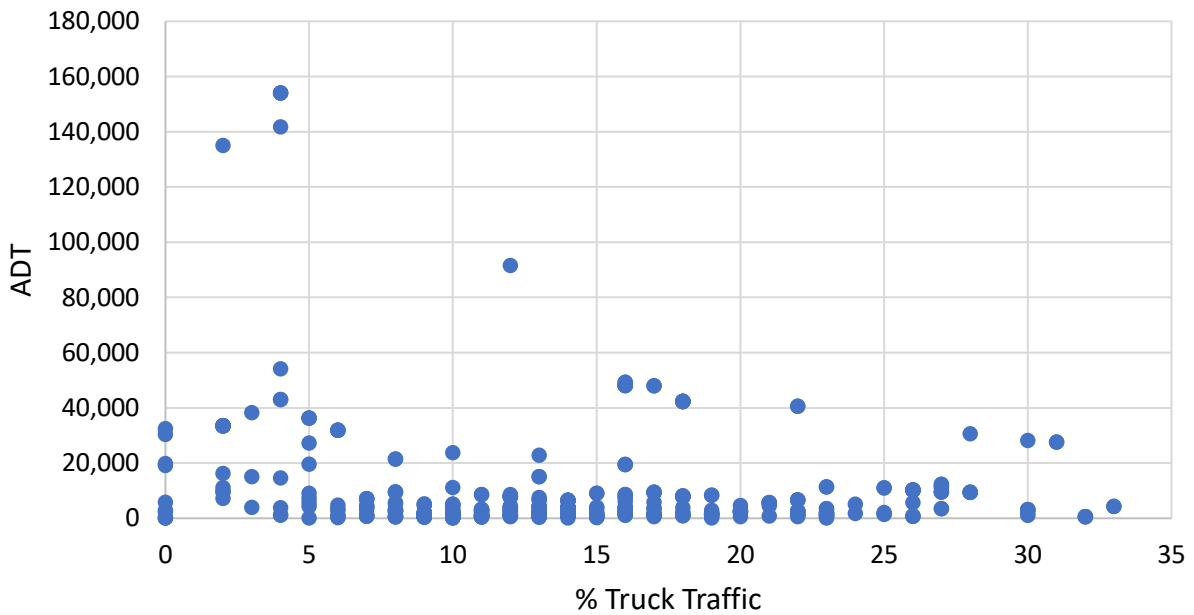


Figure 3.15: Plots of ADT and % of truck traffic for considered NDOT approach slabs

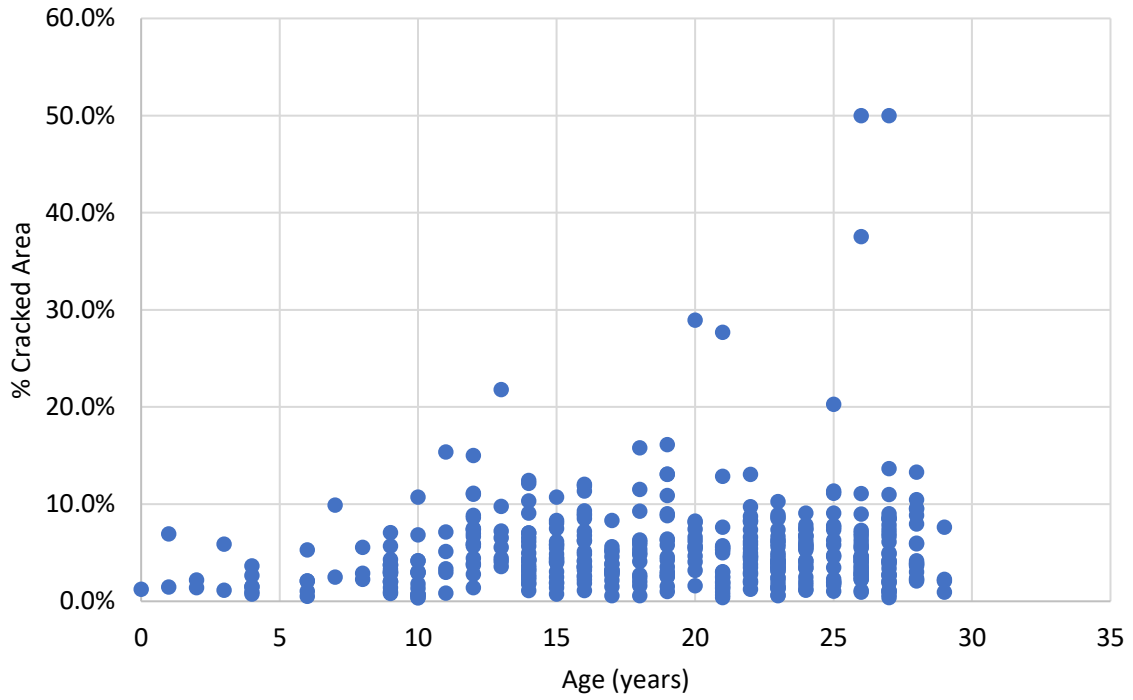


Figure 3.16: Relationship between age and % of cracked area

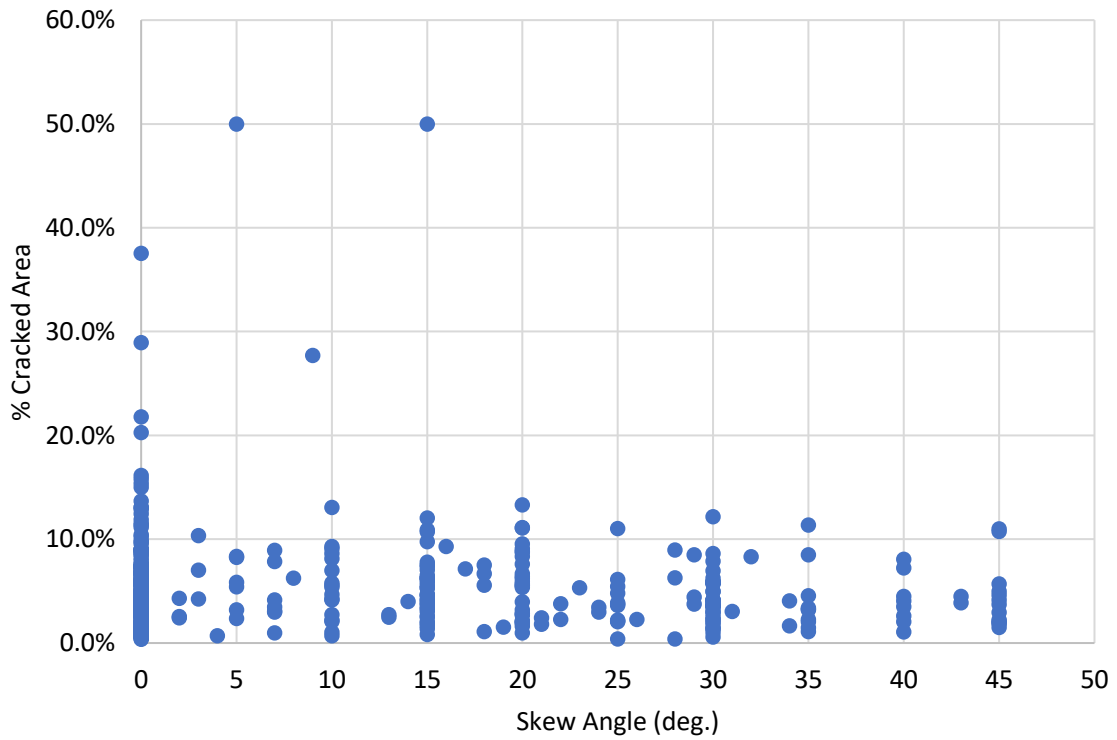


Figure 3.17: Relationship between skew angle and % of cracked area

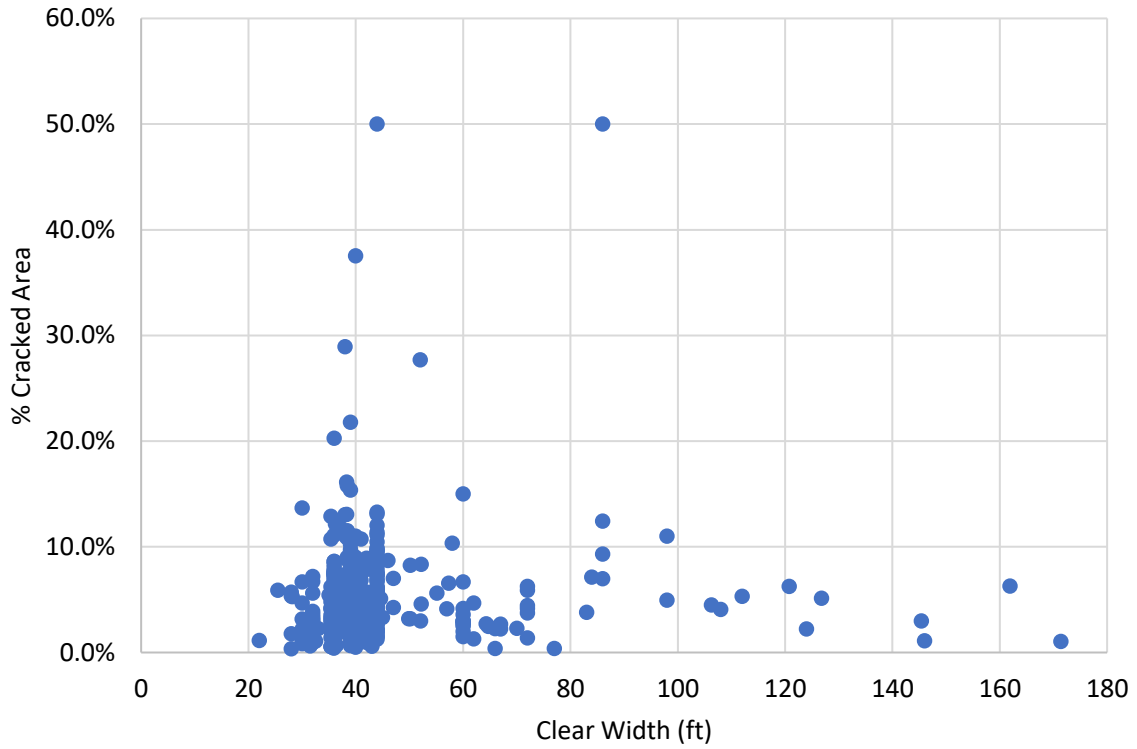


Figure 3.18: Relationship between roadway clear width and % of cracked area

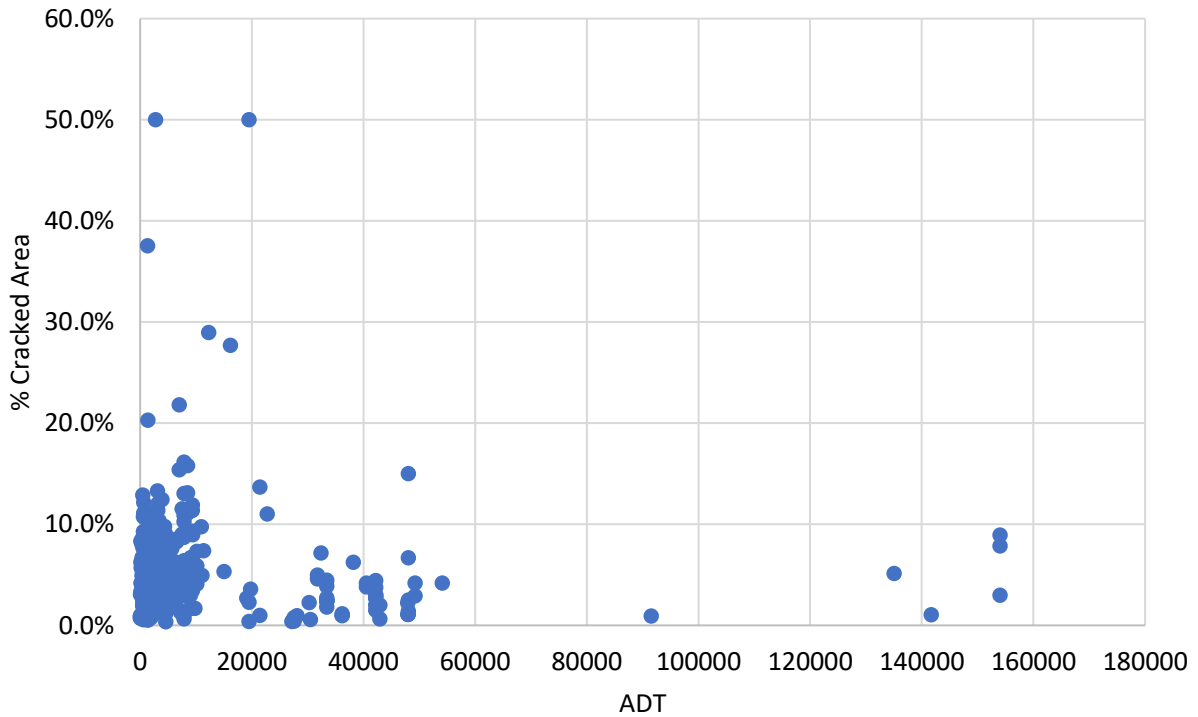
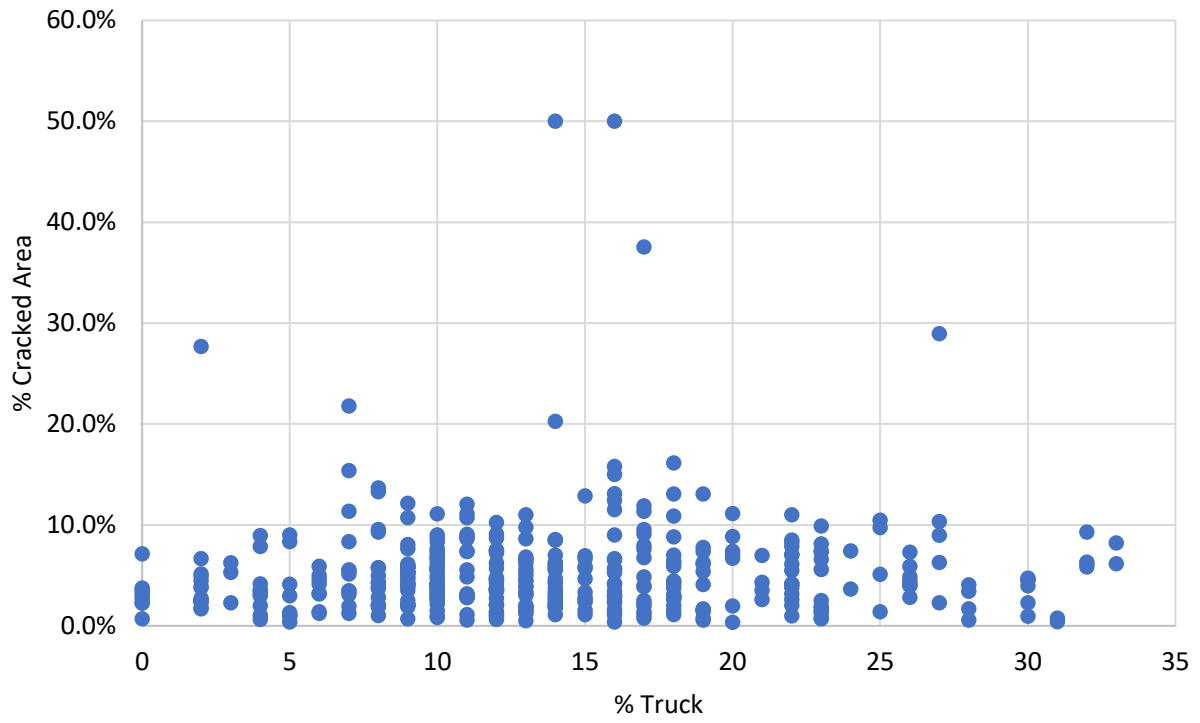


Figure 3.19: Relationship between ADT and % of cracked area



*Figure 3.20: Relationship between % truck and % of cracked area*

## Chapter 4. Analytical Investigation

### 4.1 Introduction

In order to determine the causes of approach slab cracking, an analytical investigation was conducted using finite element modeling (FEM) to simulate the behavior of a typical approach slab currently used in Nebraska (20 ft span and 14 in. thick). The analysis was conducted to evaluate the response of the approach slab to dead and live loads as well as volume changes due to shrinkage and temperature. A parametric study was also conducted by changing the values of the following parameters: skew angle, roadway width, type of longitudinal joints, abutment connection and soil friction. The values of these parameters considered in the investigation are shown in Figure 4.1. According to BOPP Manual (NDOT, 2016), the concrete used in this investigation is a normal weight concrete (150 pcf) with a specified compressive strength ( $f_c'$ ) of 4000 psi. Cracking strength (modulus of rupture) of 480 psi, modulus of elasticity (MOE) of 3987 ksi, and Poisson ratio of 0.2 were assumed according to AASHTO LRFD (2017).

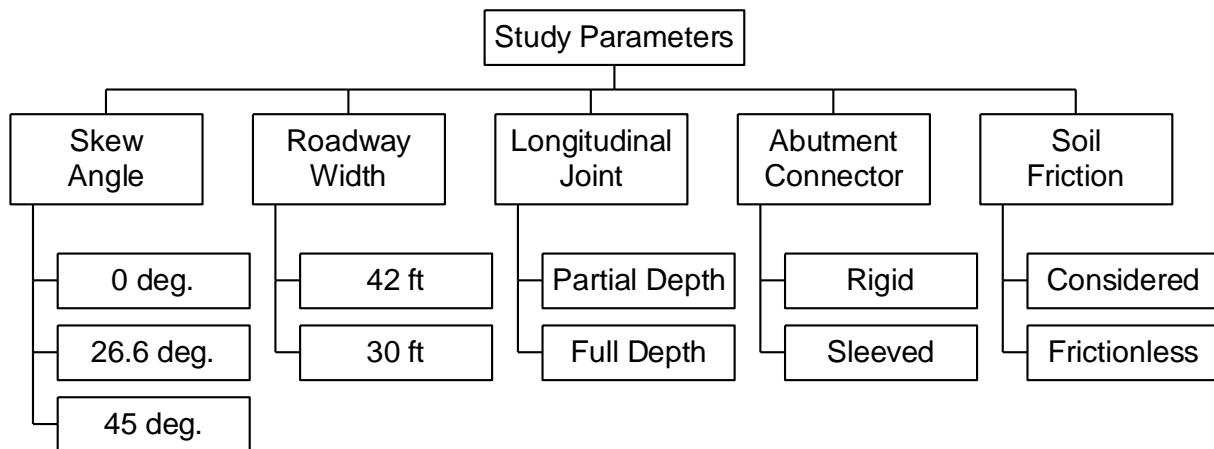


Figure 4.1: Parameters considered in the analytical investigation

The modeling of the approach slab was conducted using two modeling techniques for verification: *Solid65* element in Ansys V19 R1 as shown in Figure 4.2; and thick shell element in SAP2000 V21 as shown in Figure 4.3. The two techniques yielded similar results, therefore, the results of only the shell elements for clarity are presented here in this chapter. The approach slab was meshed to 1 ft x 1 ft thick shell elements that are either squares or parallelograms in the direction of the support lines. All elements had thickness of 14 in. except the elements at the abutment support line has thickness of 18 in. and the elements at the grade beam support line had a thickness of 16 in. The joints between approach slab and abutment were simulated as hinged supports every 1 ft to restrain movement, while the connections between the approach slab and grade beam were simulated as roller supports as there is no restriction on approach slab horizontal movement. The rail was modeled as frame elements at ends of the approach slab as shown in the extruded view of

the approach slab model in Figure 4.4. The dead load applied to the approach slab includes the own weight of the slab (100 psf) and rail (0.45 klf assuming 34 in. closed rail). Wearing surface of 25 psf and live load of the HL93, which includes lane load of 64 psf and axle loads of the design truck or design tandem shown in Figure 4.5, were applied. Two lanes were loaded and the axle loads of the tandem plus 33% impact, which controlled the design, were located following the AASHTO LRFD (2017) specifications. For volume change effects,  $\pm 45^\circ\text{F}$  was applied to simulate the strains due to shrinkage and temperature assuming a coefficient of thermal expansion used of  $6.0 \times 10^{-6} \text{ in./in./}^\circ\text{F}$ . Shrinkage calculations, shown in Appendix B, indicates that drying shrinkage strain of approach slab concrete is almost the same as that of temperature reduction of  $45^\circ\text{F}$ .

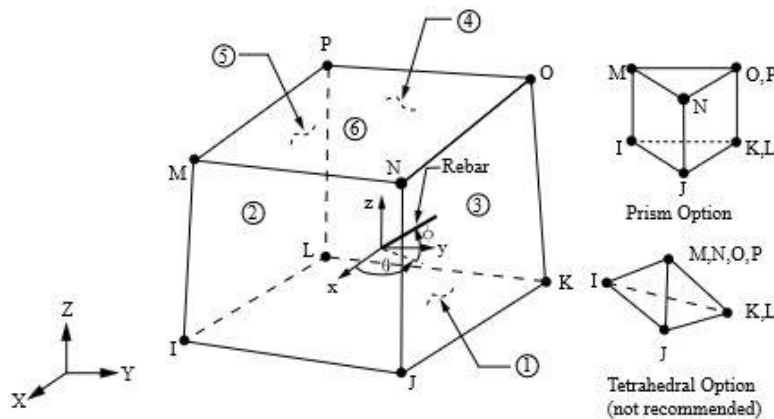


Figure 4.2: Solid Element geometry

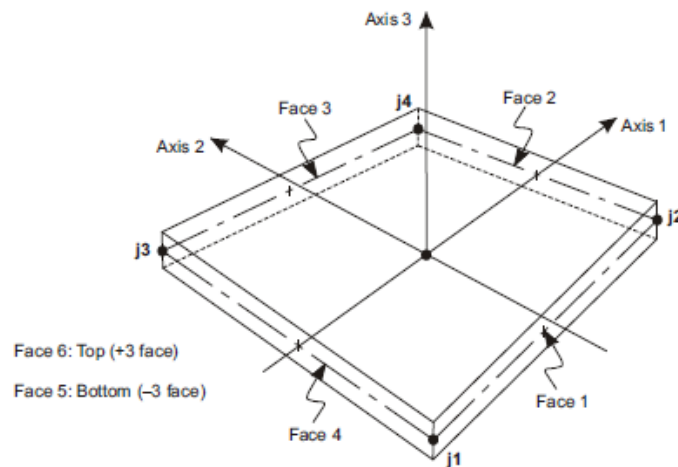


Figure 4.3: Shell Element geometry

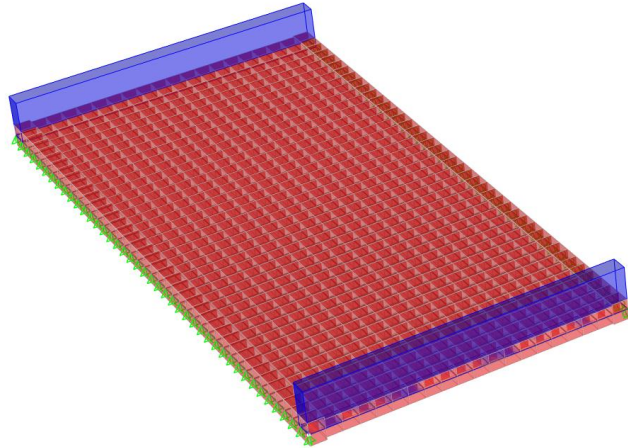


Figure 4.4: Extruded view of the approach slab model

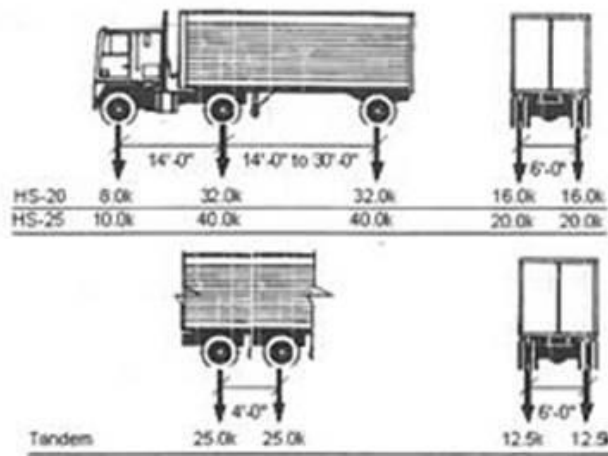


Figure 4.5: Design live load configurations

## 4.2 Effect of Skew Angle

Three bridge approach slabs with three different skew angles were investigated as shown in Figure 4.6. The bottom longitudinal service stresses were plotted for each slab as shown in Figure 4.7, which indicates that the stresses decrease as the skew angle increases. This is in agreement with the AASHTO LRFD (2017) equation 4.6.2.3-3 that calculates a reduction factor for longitudinal force effects in skewed bridges as a function of the skew angle, which is shown in Figure 4.8. To confirm this behavior, Figure 4.9 plots the deflection of the slab under dead and live loads for the three cases, which confirms that deflection decreases as skew angle increases. This is primarily due to the fact that higher skew angle creates a shorter load path as the perpendicular distance between support lines decreases. However, this also results in a change in the direction of principal stresses as shown in Figure 4.10. Therefore, it is recommended that the direction of longitudinal reinforcement follows the direction of principal tensile stresses for approach slabs with high skew angles as shown in Figure 4.11, which is in agreement with AASHTO LRFD (2017) 9.7.1.3.

Figure 4.12 shows the orientation of transverse and longitudinal reinforcement in approach slabs with no skew, skew angles less than 30 deg., and skew angles equal to or greater than 30 deg.

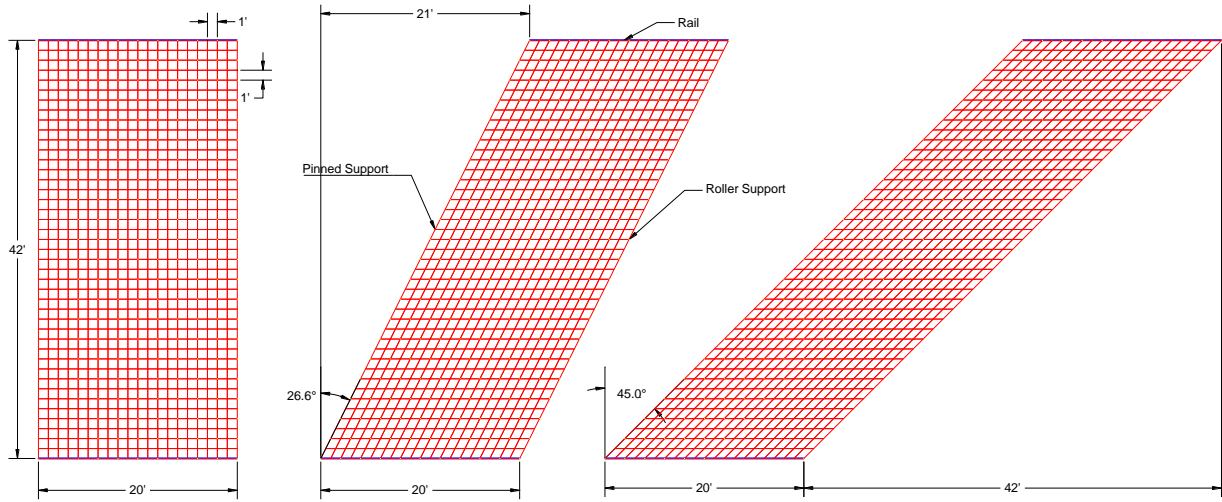


Figure 4.6: Models of approach slabs with different skew angles

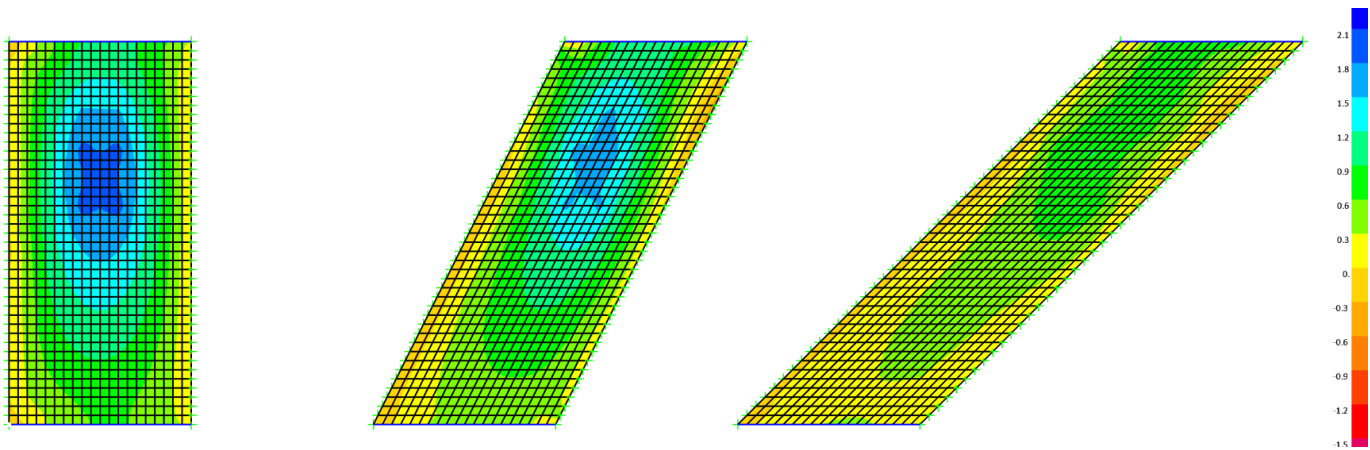


Figure 4.7: Slab bottom longitudinal stresses (ksi) due to dead and live loads

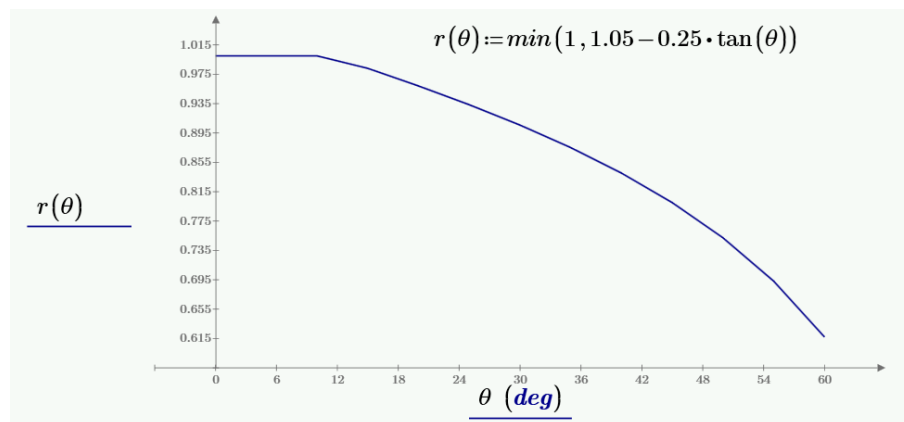


Figure 4.8: Longitudinal force effect reduction factor at different skew angles



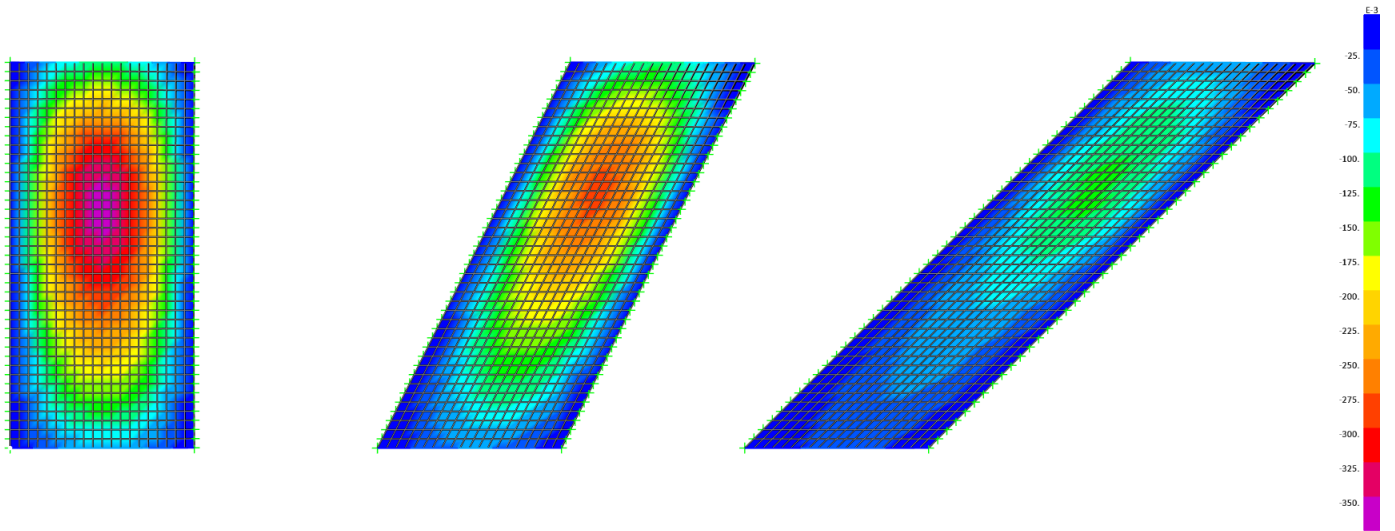


Figure 4.9: Slab deflections (in.) due to dead and live loads

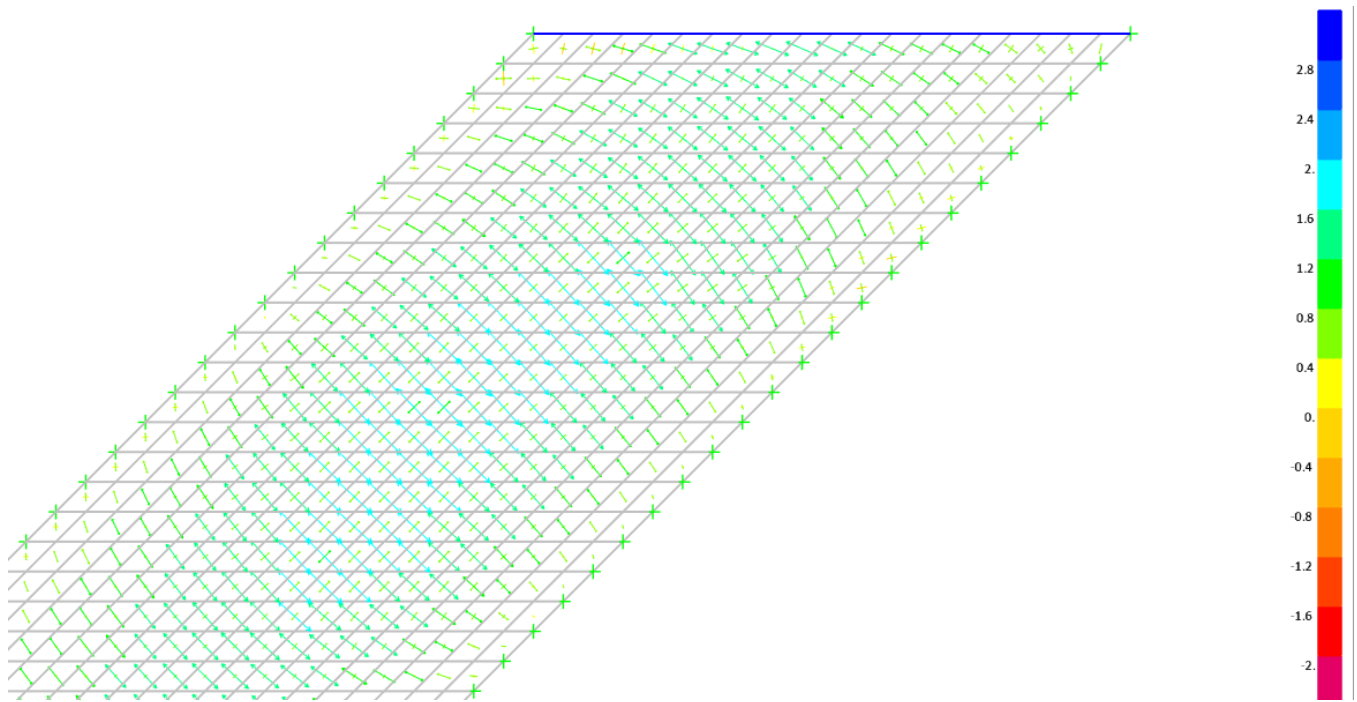


Figure 4.10: Direction of principal bottom stresses (ksi) in skewed approach slab

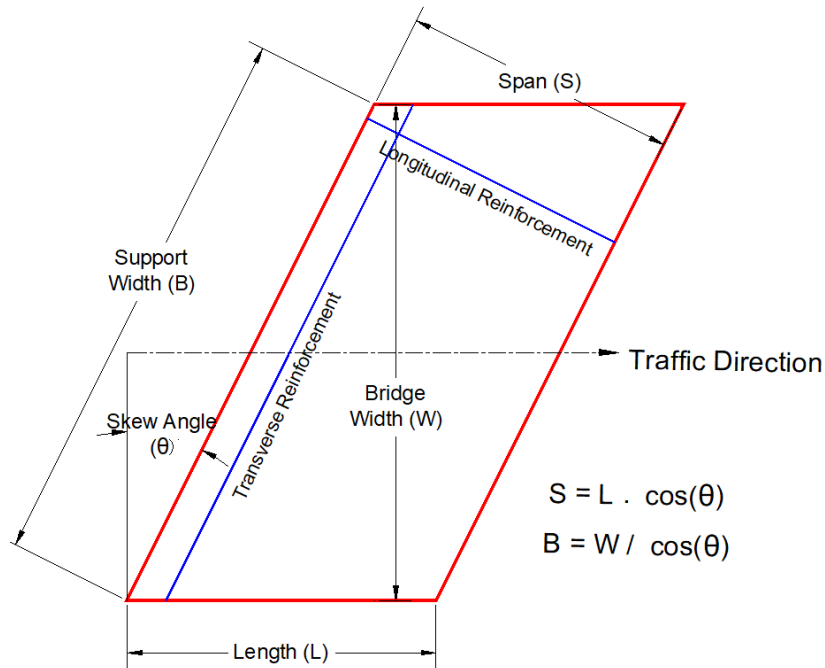


Figure 4.11: Proposed direction of longitudinal reinforcement in skewed approach slabs and corresponding AASHTO LRFD Section

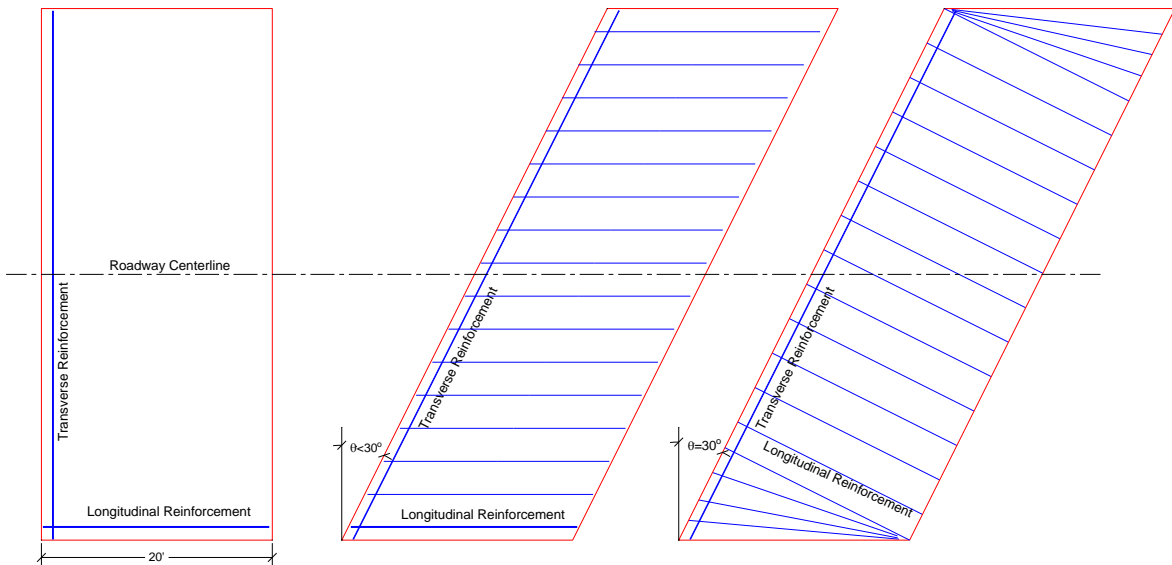


Figure 4.12: Proposed orientation of longitudinal reinforcement in approach slabs with no, low and high skew angles

The top principal service stresses due to volume changes (i.e. shrinkage and temperature) are shown in Figure 4.13 for each of the approach slabs. This figure indicates that the stresses increase as the skew angle increases. It also shows that the highest stresses are those close to the abutment support line especially at the corners due to the restraining effects of the dowel connectors and the

stresses decrease away from it. Figure 4.14 clarifies that by plotting the principal stresses as arrows, which confirms the direction of the longitudinal cracks reported in chapter 3.

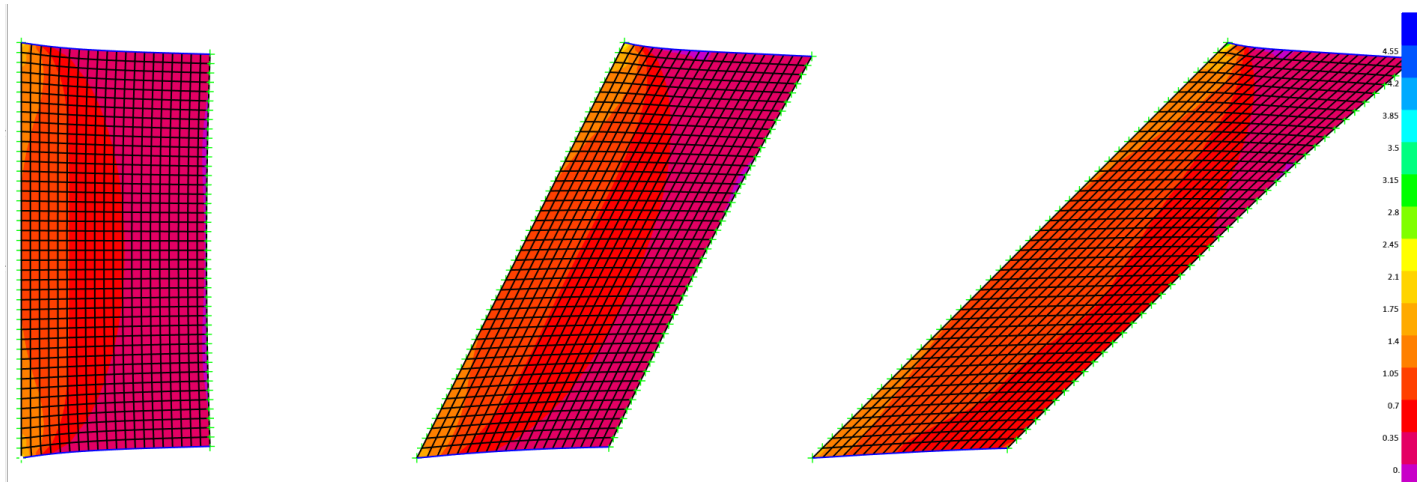


Figure 4.13: Slab top principal stresses (ksi) due to volume changes

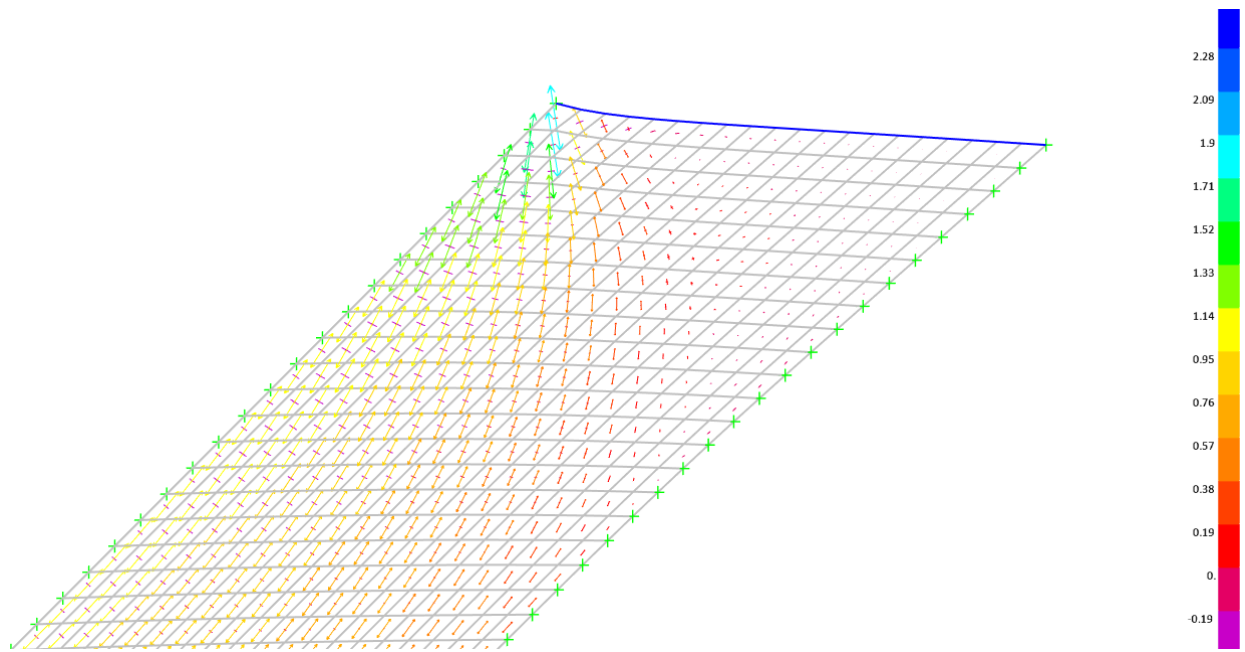


Figure 4.14: Directions of slab top principal stresses (ksi) due to volume changes

### 4.3 Effect of Roadway Width

The effect of roadway width on approach slab performance was studied on the case with highest skew angle as it was believed it is the most critical case. A 30 ft. (2 lanes) and 42 ft (3 lanes) wide approach slabs, shown in Figure 4.15, were analyzed to obtain the maximum stresses at the bottom and top fibers. Figure 4.16 shows the principal bottom stresses due to dead and live loads, while

Figure 4.17 shows the principal top stresses due to volume changes. Both figures indicate that there is not significant difference in approach slab stresses due to changes in the roadway width.

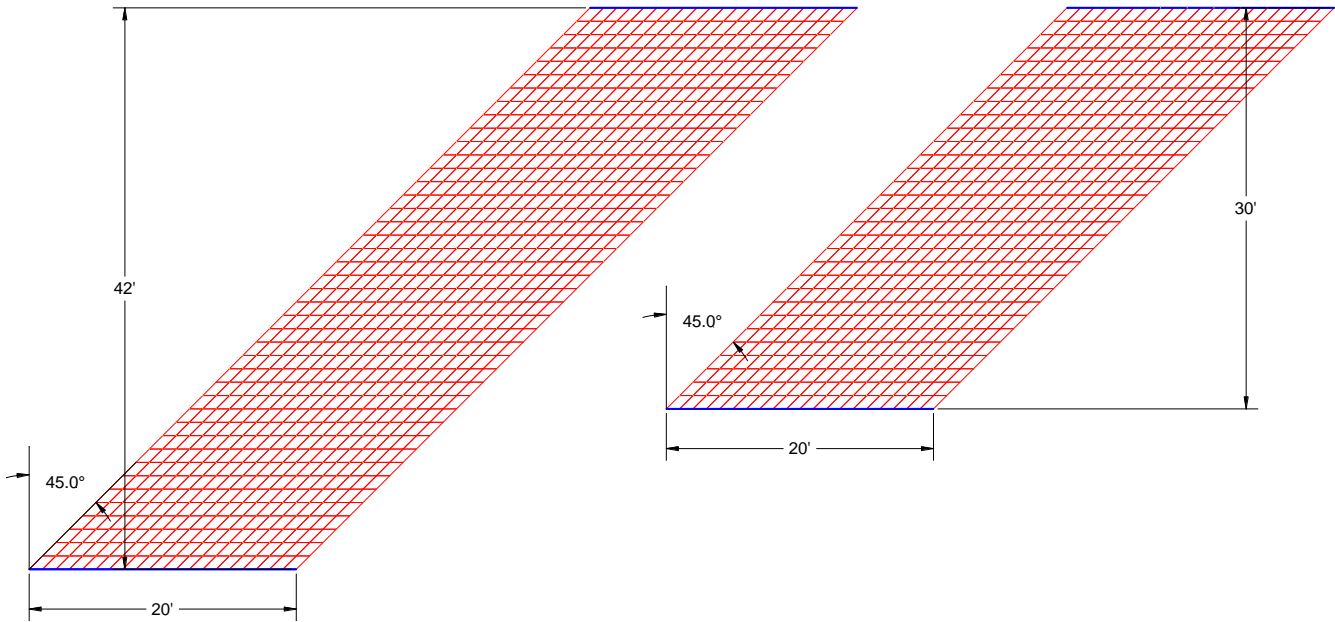


Figure 4.15: Models of approach slabs with different roadway width

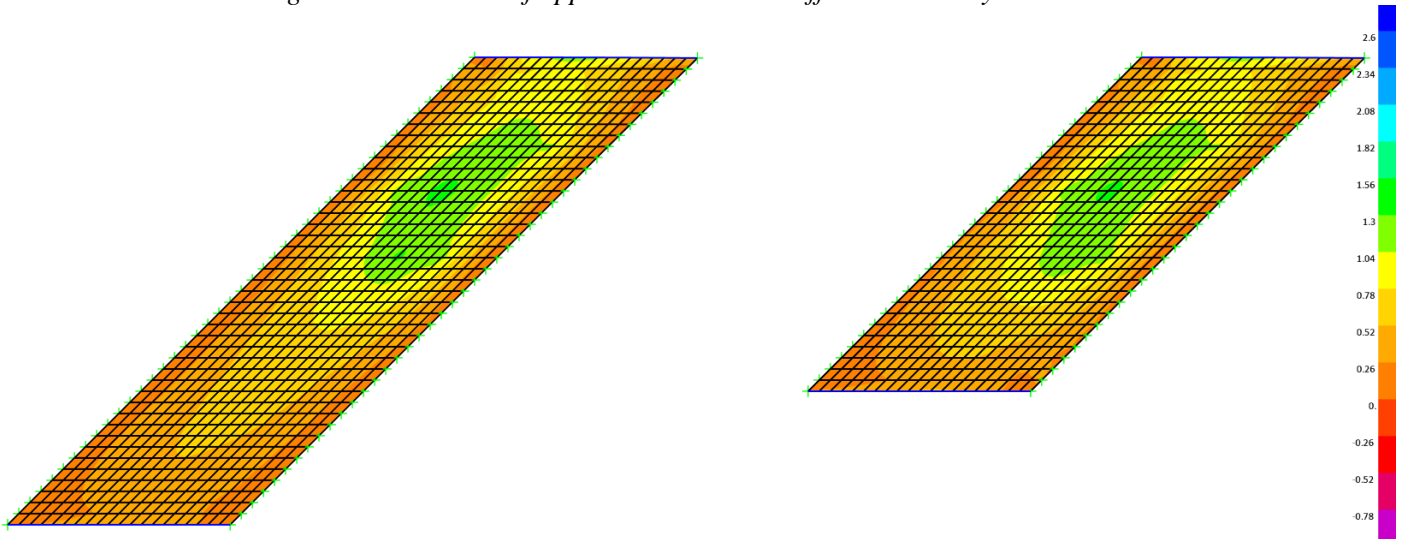


Figure 4.16: Slab bottom longitudinal stresses (ksi) due to dead and live loads

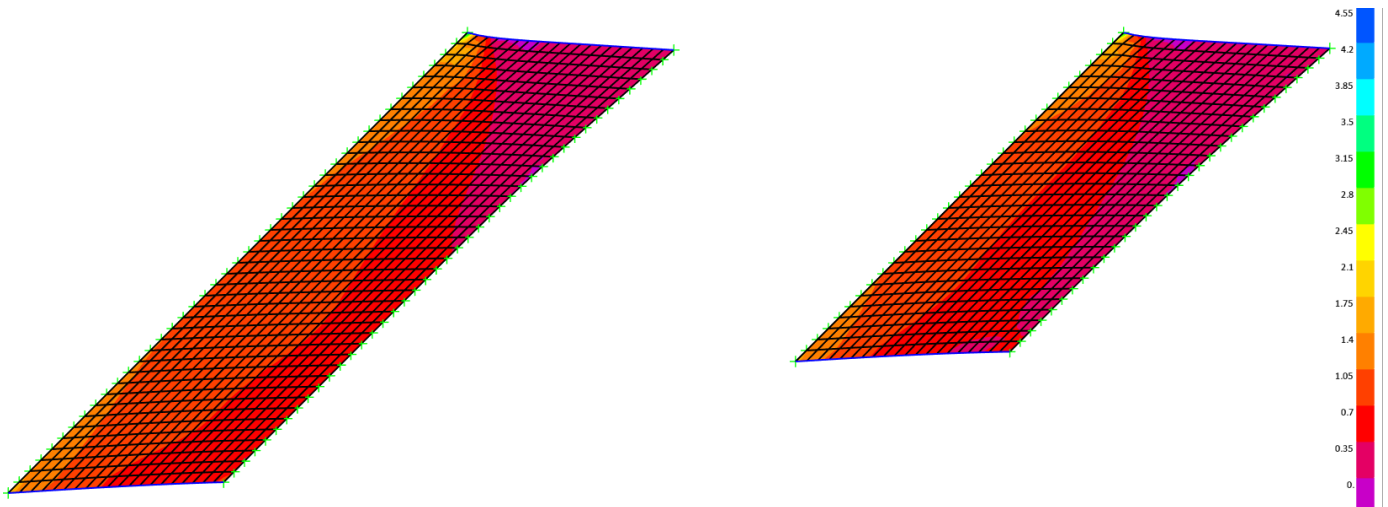


Figure 4.17: Slab top principal stresses (ksi) due to volume changes

#### 4.4 Effect of Longitudinal Joint Type

According to NDOT BOPP (2016) section 2.2.4 on approach slab policy, the approach and paving sections of bridge approaches should have a longitudinal joint placed at the centerline of the roadway or phase line if not phased about the centerline. On approaches where half the clear roadway exceeds 21 ft., additional longitudinal joints shall be placed at the edges of the 12' traffic lanes. The minimum spacing from the last joint to outside edge of approach should not be less than 10 ft. Figure 4.18 shows the details of a typical longitudinal joint, which is a partial-depth joint.

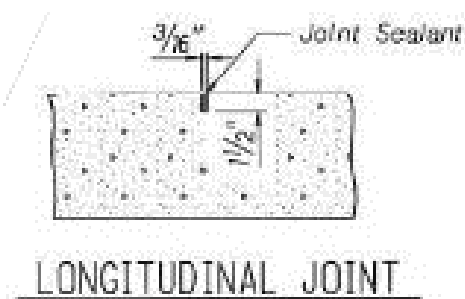


Figure 4.18: Typical longitudinal joint in approach slab

Another option is the full-depth longitudinal joint, which is similar to NDOT construction joint shown in Figure 4.19. Also, Iowa DOT has a full-depth longitudinal joint (KS-2) proposed for bridge approaches as shown in Figure 4.20 (King, 2020). The main difference between the two joints is the use of 30 in. long #5 every 12 in. along the joint to act as a dowel across the shear key. The effect of longitudinal joint type on approach slab performance was studied in the case with no skew angle. Two slabs were analyzed: one without longitudinal joint and the other with full-depth longitudinal joint at the middle as shown in Figure 4.21. Figure 4.22 shows the top stresses in the two slabs due to shrinkage/temperature effects. The figure indicates that the full-depth longitudinal joint is more effective in reducing transverse stresses than the partial-depth longitudinal joint.

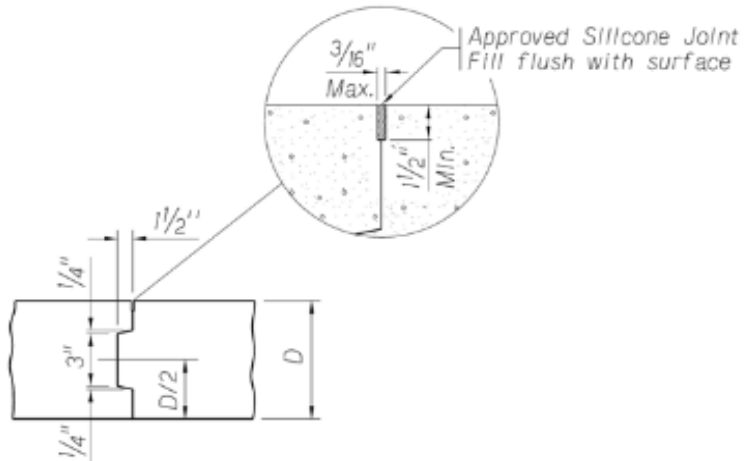


Figure 4.19: Typical NDOT construction joint

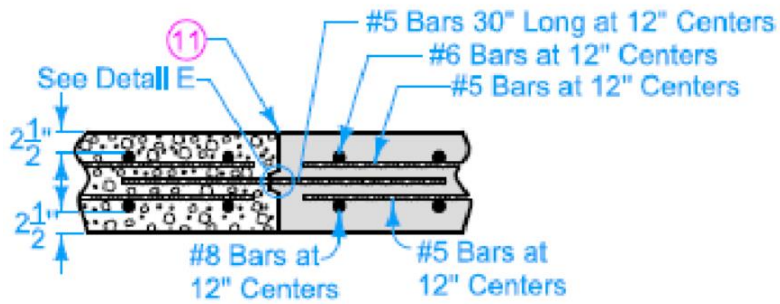


Figure 4.20: IowaDOT KS-2 longitudinal contraction joint (King, 2020)

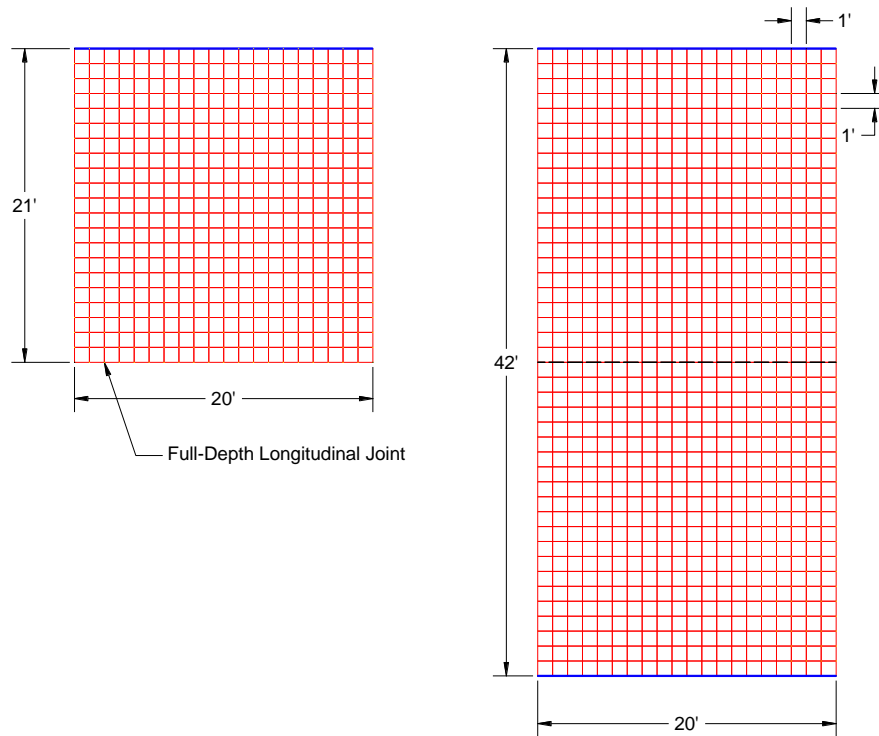


Figure 4.21: Models of approach slabs with different types of longitudinal joints

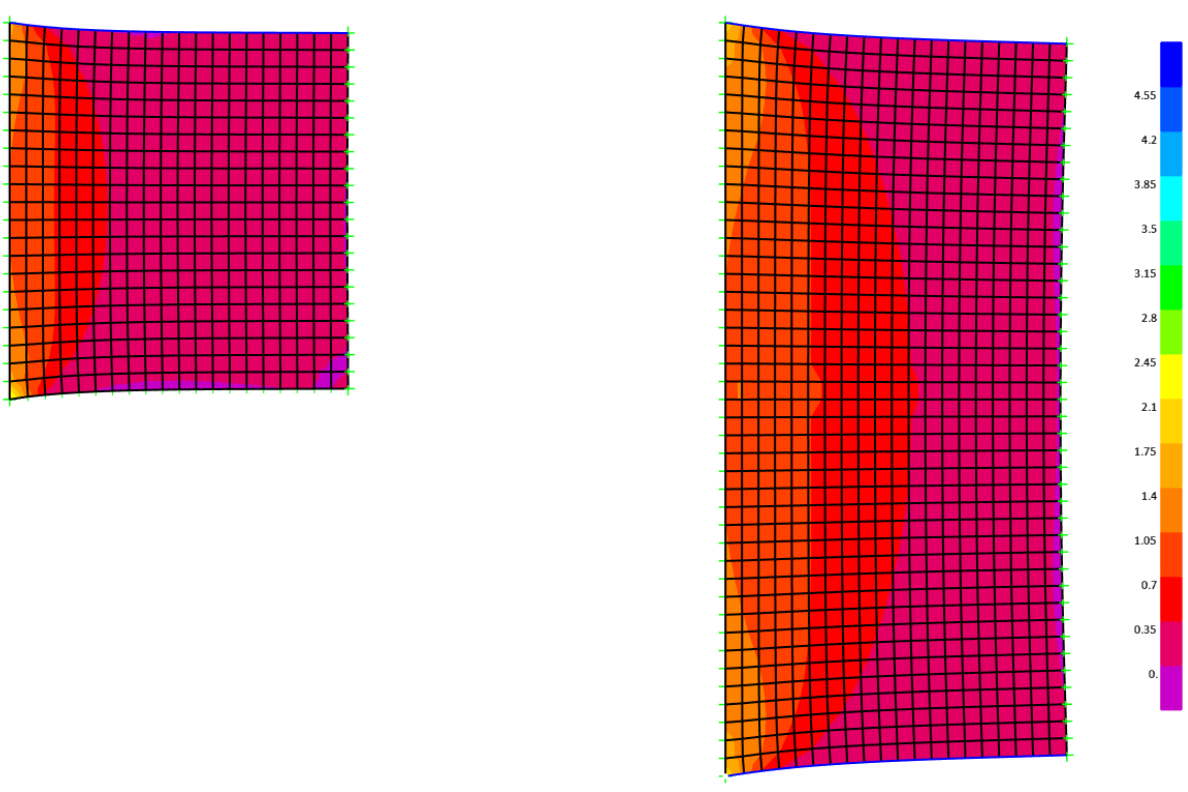


Figure 4.22: Slab top principal stresses (ksi) due to volume changes

#### 4.5 Effect of Abutment Connector Type

In integral abutment systems, the approach slabs are rigidly connected to the backwall so they are allowed to move with the superstructure and abutments. Expansion joints are provided at the grade beam ends of the approach slabs. Figure 4.23 shows the #6 connectors every 12 in. at the abutment end to be embedded into the approach slab. It is believed that these dowels restrain the movement of the approach slab due to volume changes resulting in the common longitudinal cracks.



Figure 4.23: Current practice of using #6 @12 in. dowels to connect approach slab at the abutment

Therefore, it is proposed to use sleeved connectors that partially allow horizontal movement of approach slabs due to volume changes, which reduces the stress concentration at the connector location. Figure 3.2 in the previous chapter showed an example of using 3 in. polystyrene blocks on the paving section connectors. Figure 4.24 shows a similar method but using 2 in. diameter and 4 in. long cylindrical sleeves to be placed around connectors. These sleeved connectors will act as springs rather than hinged supports with horizontal stiffness that depends on the connector diameter and the sleeved length. The calculated stiffness of the spring that corresponds to #6 connector with 4 in. sleeve was found to be 84 kip/in. as shown in Appendix B. Figure 4.25 shows the models of the approach slabs using springs that represents two cases: #6 bars at 12 in. spacing and #7 bars at 24 in. spacing. Figure 4.26 shows that using sleeved connectors does not have any effect on the stresses due to gravity loads (dead and live), while Figure 4.27 shows that they resulted in a significant reduction in the stresses due to volume changes (shrinkage and temperature effects). Figure 4.27 also shows there is no significant difference between using #6@12 in. and #7@24 in. sleeved connectors, which suggests that using #7 @24 in. could be more cost effective.



Figure 4.24: Methods of providing sleeved connectors

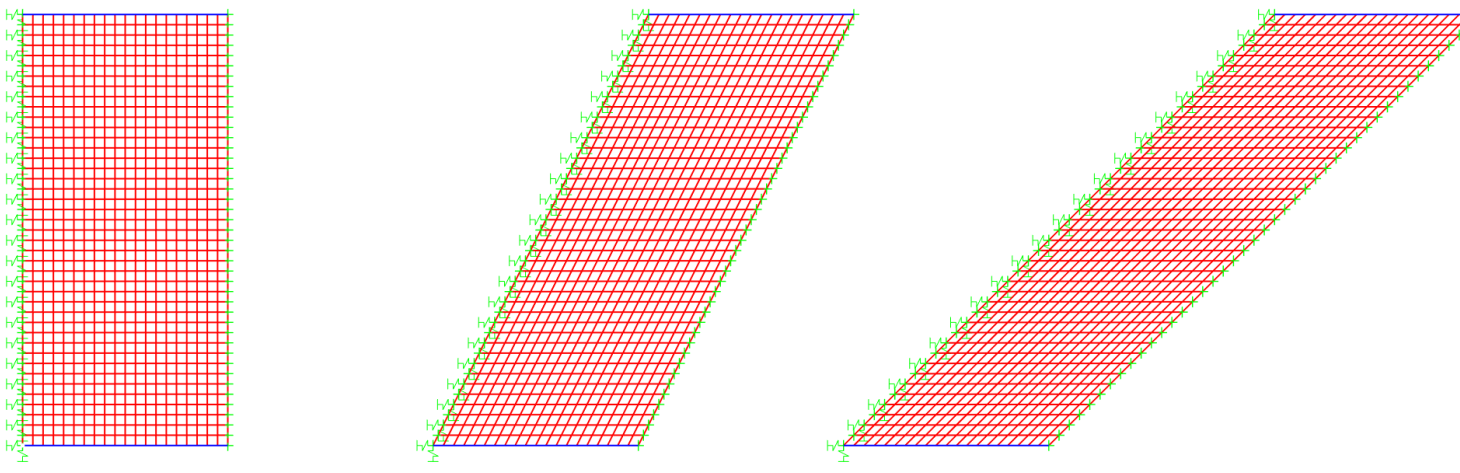


Figure 4.25: Models of approach slabs with sleeved connectors



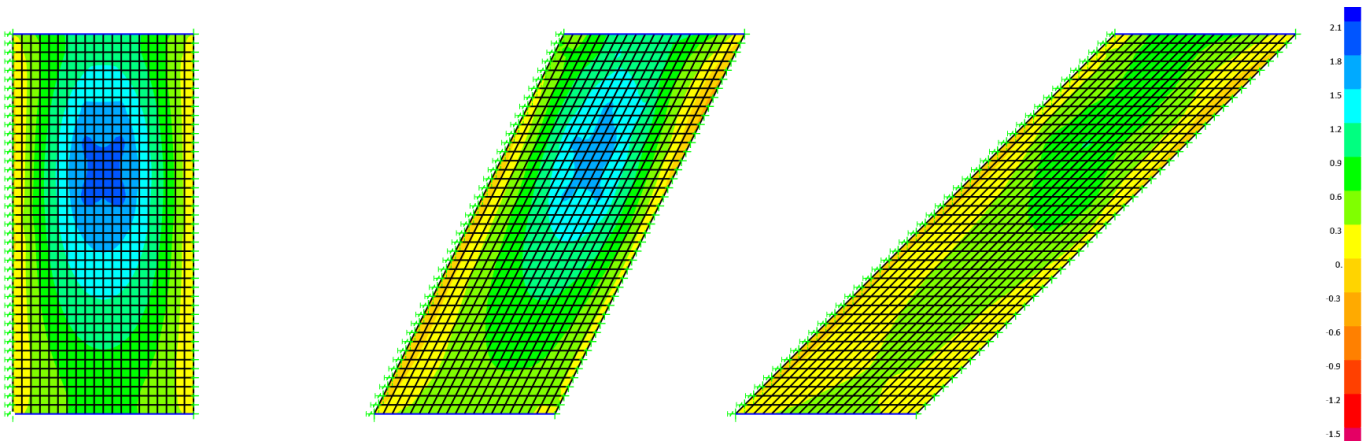
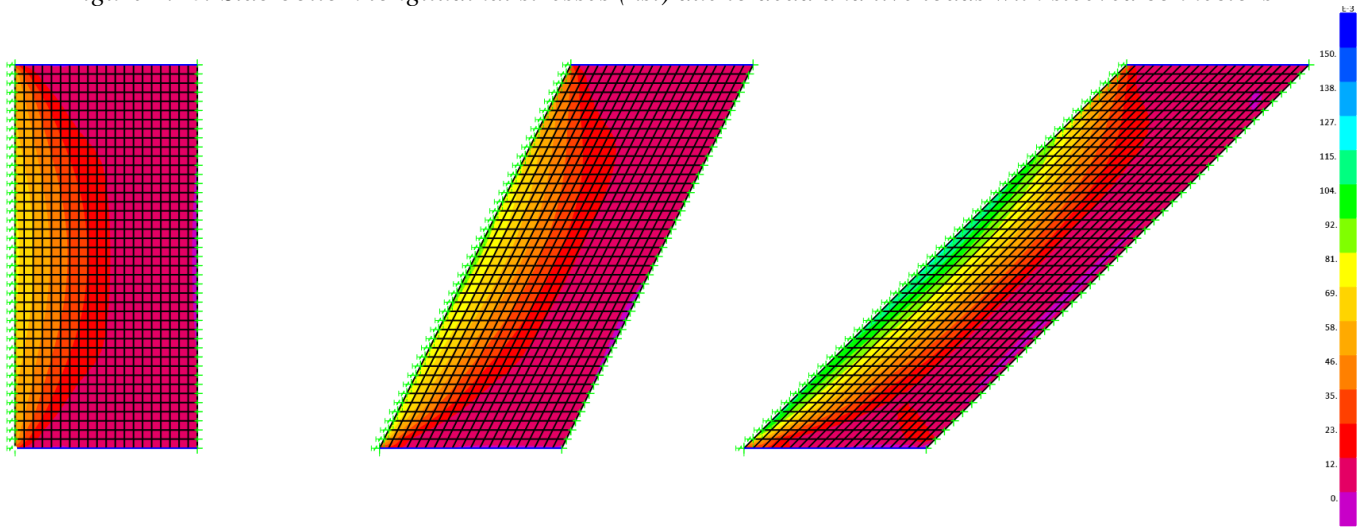
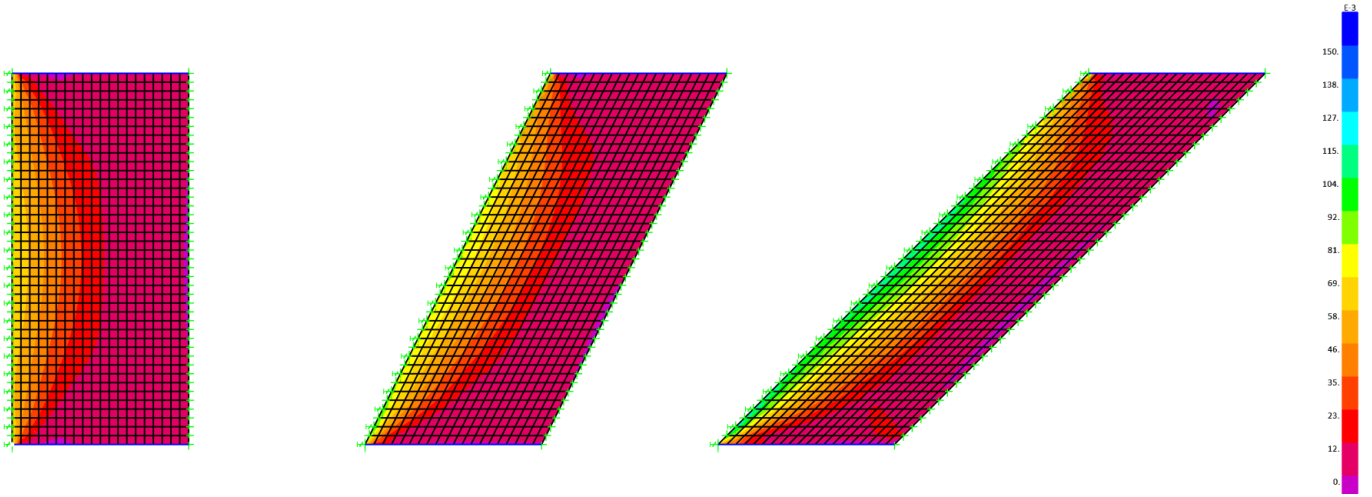


Figure 4.26: Slab bottom longitudinal stresses (ksi) due to dead and live loads with sleeved connectors



(a)



(b)

Figure 4.27: Slab top principal stresses (ksi) due to volume changes using: a) #6@12"; and b) #7@24" sleeved connectors

## 4.6 Effect of Soil Friction

In all the previous models, it was assumed that there is no friction between the approach slab and the backfill underneath it, which does not affect the results due to gravity loads. However, this could have effect on the slab stresses due to shrinkage and temperature and abutment movement. In order to evaluate the effect of soil friction on the stresses in the approach slab, horizontal springs were added to all the nodes to simulate the resistance to horizontal movement due to soil friction. A friction coefficient of 0.6 and modulus of subgrade reaction of 247 pci is assumed for a fair soil quality based on the calculations shown in Appendix B. Figure 4.28 shows the top principal stresses in the approach slab due to volume changes when soil friction is considered. Comparing these stresses with those shown in Figure 4.27 (without friction) indicates that soil friction increases the stresses slightly, which could increase approach slab cracking. Figure 4.29 shows the top principal stresses in the approach slab due to 1 in. abutment movement when soil friction is considered. This figure also indicates that there are additional stresses due to abutment movement. Therefore, it is recommended to add frictionless sheets underneath the approach slab to minimize/eliminate these effects.

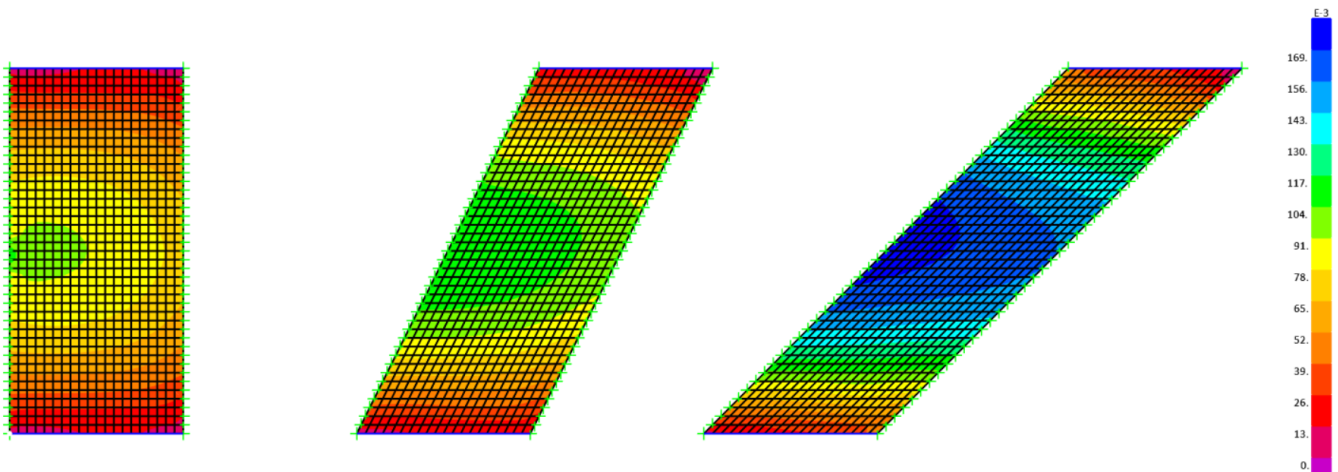


Figure 4.28: Slab top principal stresses (ksi) due to volume changes with considering soil friction

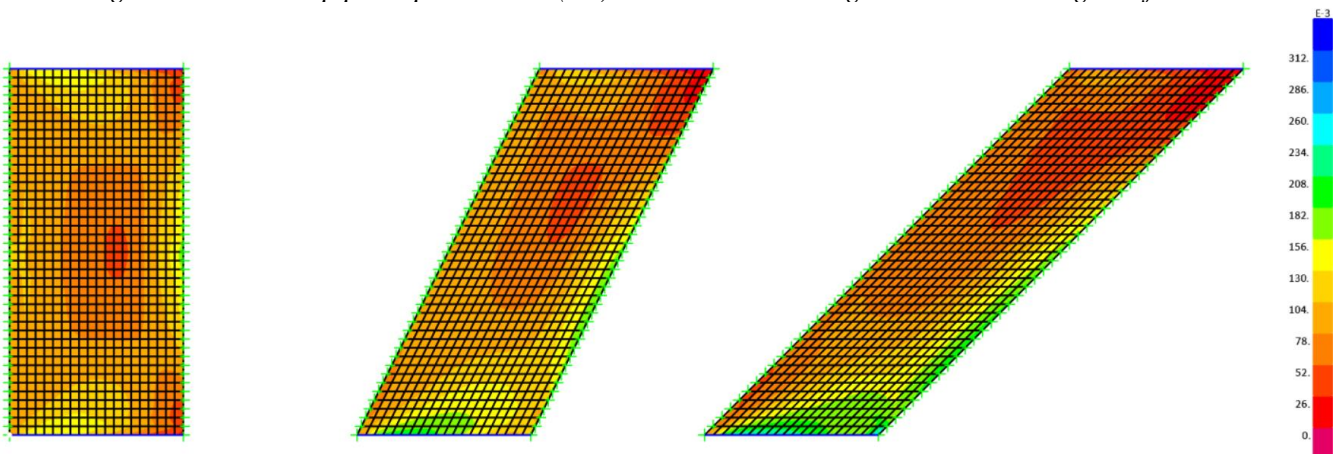


Figure 4.29: Slab top principal stresses (ksi) due to abutment movement with considering soil friction

Also, in all the previous models, the effect of backfill in supporting the approach slab was neglected. Although this is more conservative for the case of dead and live loads, it is not conservative for the case of differential settlement. Therefore, vertical springs with stiffness equal to 35.5 kip/in (calculated as shown in Appendix B) were added to every node to simulate the effect of subgrade reaction when differential settlement of 1 in. between the grade beam and abutment occurs. Figure 4.30 shows very high principal stresses at the top of the approach slab due to differential settlement when full soil support exists, which will result in transverse cracking. These stresses do not exist if the approach slab is assumed as simply supported at the ends with no subgrade reaction. Partial soil support, which is more realistic, will result in lower stresses that could lead to transverse cracking similar to that shown in Figure 3.8. This analysis emphasizes the importance of having pile-supported grade beams and abutments, which reduce the differential settlement between the ends of the approach slabs.

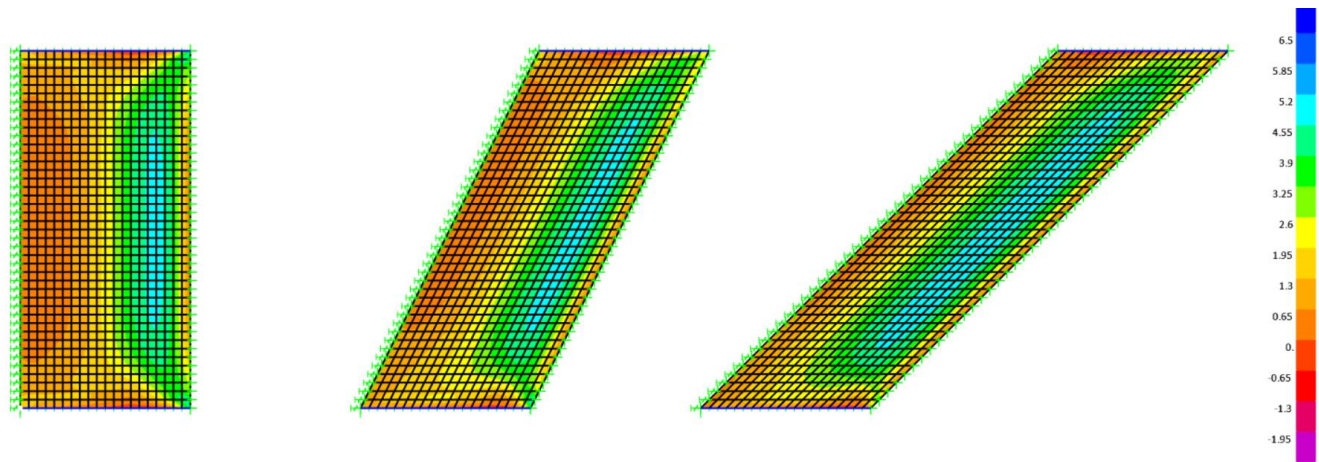


Figure 4.30: Slab top principal stresses (ksi) due to differential settlement

#### 4.7 Proposed Changes

Based on the results of the analytical investigation presented in this chapter, the following changes to the CIP concrete approach slab design and detailing are proposed to improve its performance and minimize the longitudinal cracking commonly observed in the current design (Figure 4.31):

1. Use two 4 mil or one 6 mil polyethylene sheets underneath the approach slab to minimize soil friction.
2. Use 2 in. diameter and 4 in. long polystyrene around connectors between the approach slab and backwall. These connectors can be #7 at 24 in. instead of #6 at 12 in. to reduce cost.
3. Use one full-depth longitudinal contraction/construction joint at the middle of the approach slab to reduce cracking. Additional longitudinal joints remain partial-depth joints.
4. Increase the number of top transverse reinforcement to be #5 at 6 in. in the 10 ft close to the abutment end to better control cracking. The remaining 10 ft will have #5 at 12 in.
5. For highly skewed slabs, place longitudinal reinforcement perpendicular to support lines.

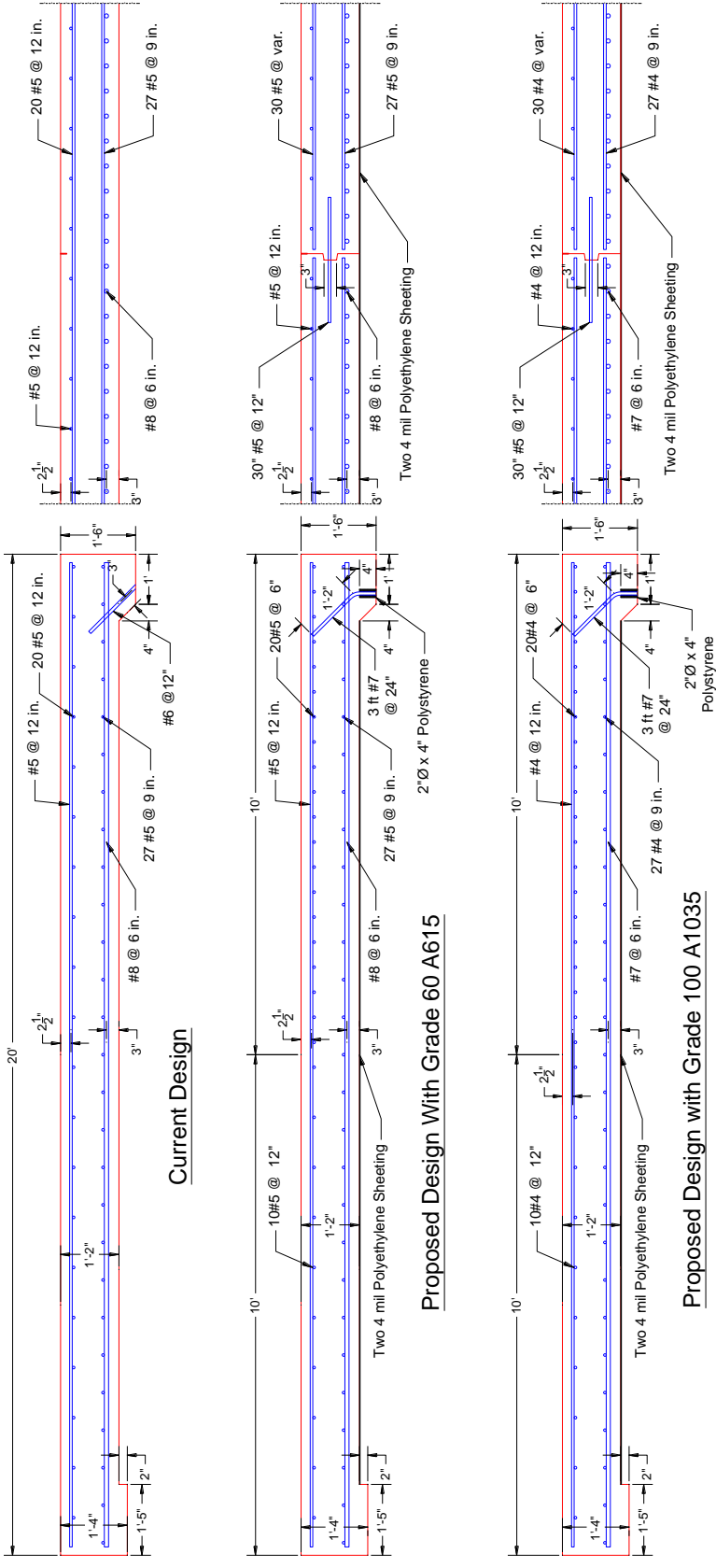


Figure 4.31: CIP concrete approach slab current and proposed designs

## **Chapter 5. Precast Concrete Approach Slabs**

### **5.1 Introduction**

Construction of CIP concrete approach slabs faces several challenges, such as unexpected delays due to weather conditions, inconsistencies due to uncontrolled environment and lack of skilled labor, and long duration of forming, casting, and curing concrete. These challenges could affect the speed and quality of construction as well as long-term performance of CIP concrete approach slabs. In addition, the analysis conducted earlier indicated that volume changes of restrained CIP concrete approach slabs due to shrinkage and temperature effects are major contributors to their premature cracking. Precast concrete (PC) approach slabs minimize, if not eliminate, most of these challenges as they are fabricated in a controlled environment, independent from weather conditions and under tighter quality control procedure that results in higher product quality. Moreover, PC approach slab panels are small in size and erected and connected when most of the shrinkage already took place before being restrained, which minimizes shrinkage cracking. Therefore, several organizations, such as Precast/Prestressed Concrete Institute (PCI) and state DOTs, developed PC approach slab systems, some of which were implemented in demonstration projects recently to evaluate their constructability, performance, and economics. The next section presents examples of these systems. Appendix C shows photos of the production and construction of these systems .

### **5.2 Current Practices**

PC approach slab systems can be classified as shown in Figure 5.1. Full-width panels are the least common as they require using longitudinal post-tensioning to connect the panels in the traffic direction, which increases construction cost and duration. Also, full-width panels need to have a variable thickness in order to have a crown in the middle as shown in Figure 5.2 (Merritt et.al., 2007). Partial-width panels can be produced with constant thickness as there will be a longitudinal joint at the location of the crown, which simplifies fabrication. Partial-width panels can be full-length panels, as shown in Figure 5.3 or partial-length panels, as shown in Figure 5.4. Full-length panels have the advantage of being either prestressed or non-prestressed, while partial-length panels require longitudinal post-tensioning in addition to transverse post-tensioning in most cases.

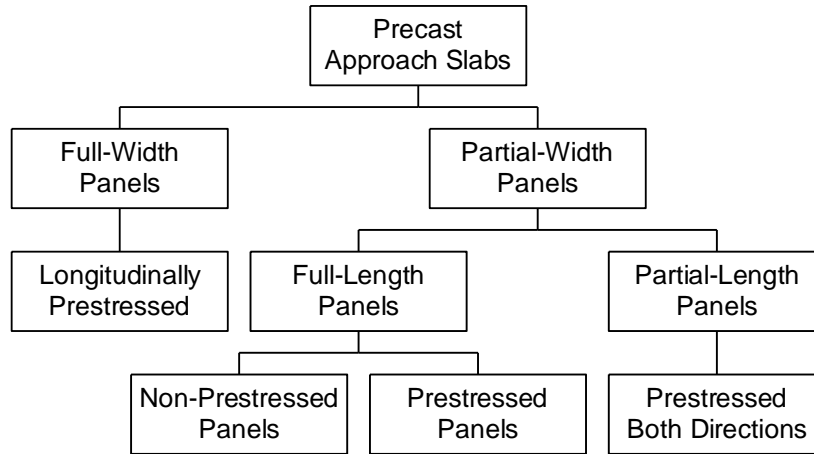


Figure 5.1: Classification of Precast Concrete Approach Slabs

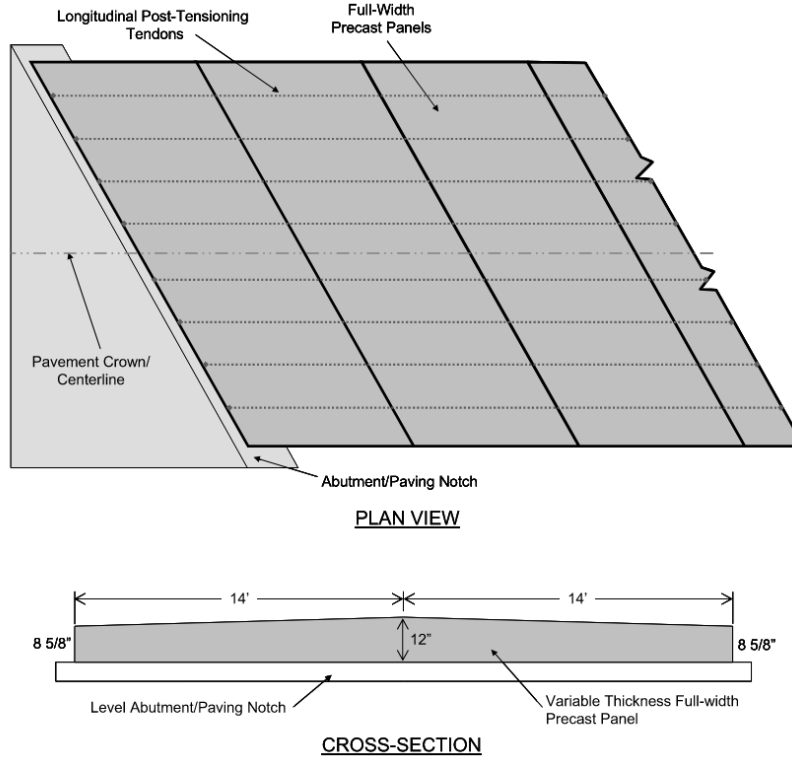


Figure 5.2: Full-Width Precast Concrete Approach Slabs (Merritt et al., 2007)

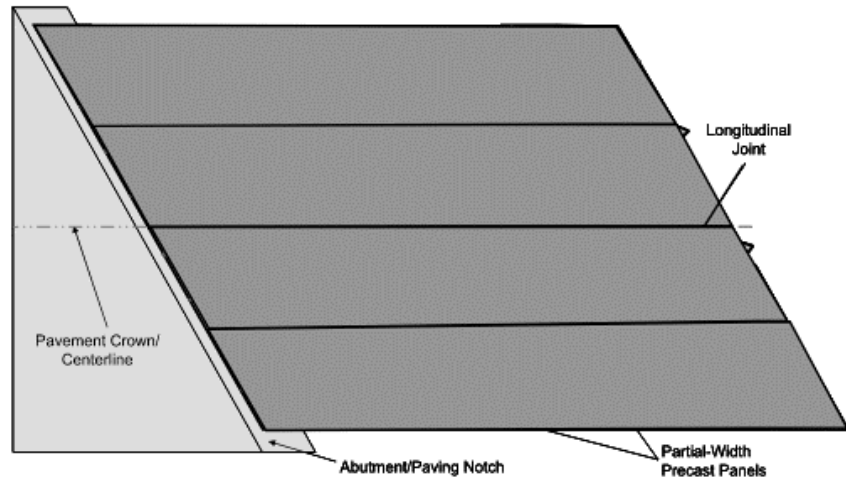


Figure 5.3: Partial-Width Full-Length Precast Concrete Approach Slabs

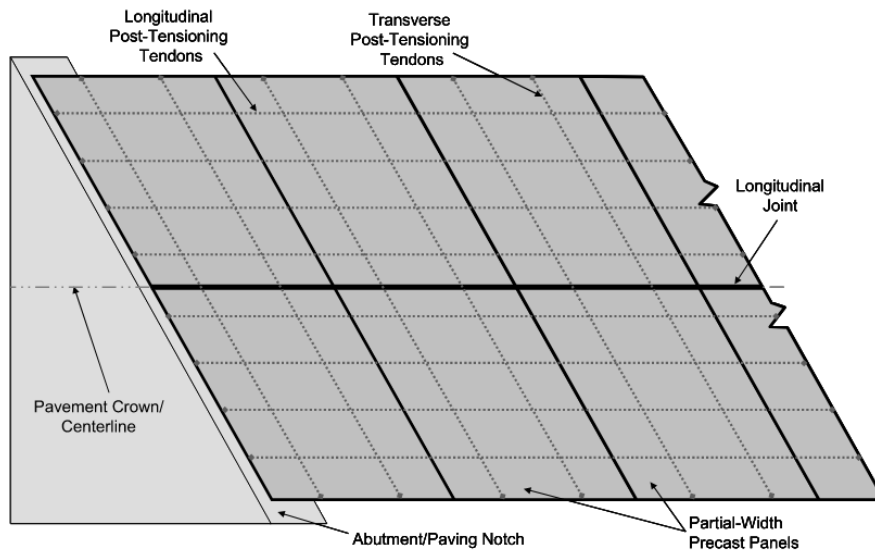
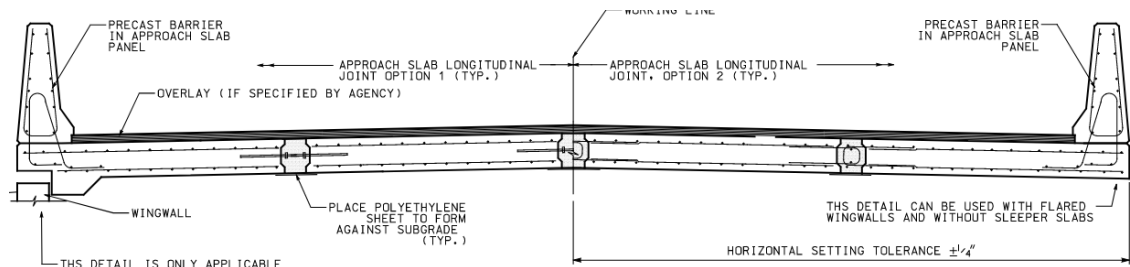


Figure 5.4: Partial-Width Partial-Length Precast Concrete Approach Slabs (Merritt et al., 2007)

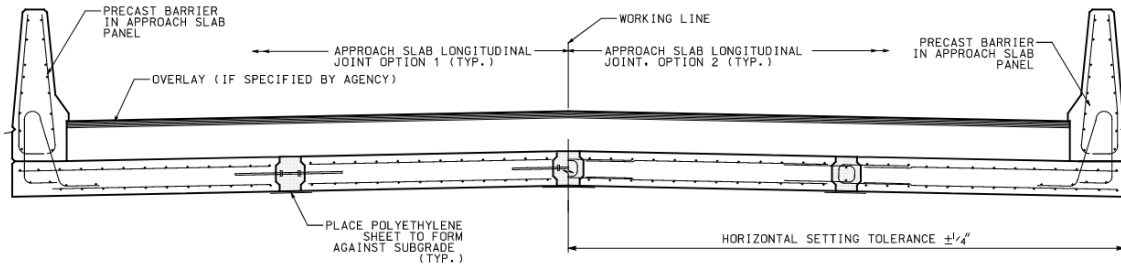
In 2012, PCI published guidelines presenting suggested design and detailing of precast concrete approach slabs. Two typical designs are presented for the following two cases: surface approach slab and sub-surface approach slab, as shown in Figure 5.5. Also, the guidelines contain different configurations for longitudinal joints as shown in Figure 5.6, and connections at the abutment and sleep slab as shown in Figure 5.7. Below are some of the design guidelines recommended by PCI:

- Maximum panel width is 12 ft. including any projecting reinforcement
- Maximum panel weight is 100 kips
- Minimum concrete compressive strength 5,000 psi
- Use shrinkage compensating admixture for site-cast concrete
- Flowable grout of the same concrete strength is used to fill small voids or gaps



**TYPICAL SECTION: SURFACE APPROACH SLAB WITH INTEGRAL BARRIER**

NOTE: APPROACH SLABS CAN BE CONSTRUCTED WITHOUT INTEGRAL PARAPETS. CONSULT AGENCY STANDARDS



**TYPICAL SECTION: SUB-SURFACE APPROACH SLAB WITH INTEGRAL BARRIER**

Figure 5.5: Surface approach slab (top) and sub-surface approach (bottom) (PCI, 2012)

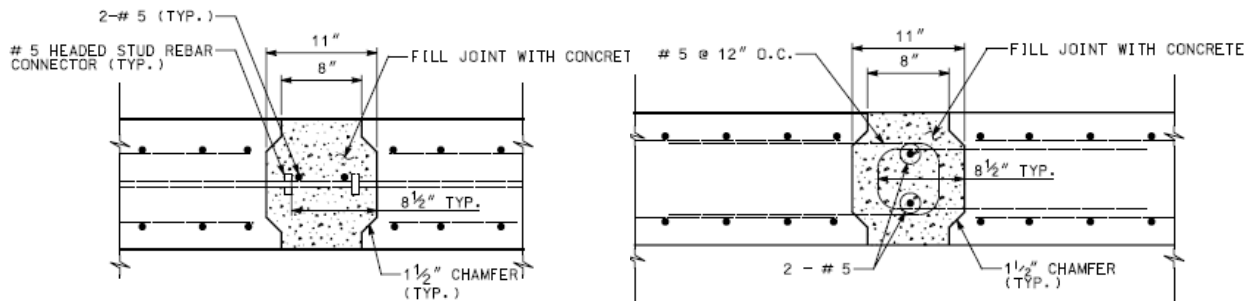


Figure 5.6: Options of longitudinal joints (PCI, 2012)

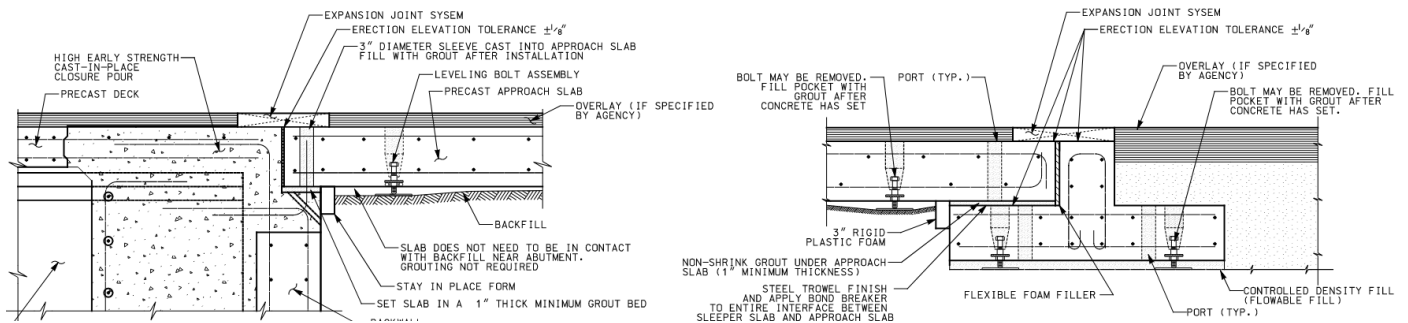


Figure 5.7: Connections at the abutment (left) and at sleeper slab (right) (PCI, 2012)



Merritt et.al. (2007) reported the replacement of the approach slab of a bridge on Highway 60 near Sheldon, IA by eight 12 in. thick precast concrete panels as shown in Figure 5.8. Six panels were rectangular with dimensions of 20 ft. x 14 ft. each and two panels were skewed. The precast slabs were post-tensioned in both directions using 0.6 in. diameter Grade 270 7-wire stands at 24 in. spacing and a flowable grout was used to fill the ducts. Each precast panel had #8 at 12 in. and #6 at 24 in. as bottom and top longitudinal reinforcement, respectively. Each panel had #5 at 12 in. for top and bottom transverse reinforcement. A key-shaped transverse joint was used to connect the panels using epoxy after aligning the longitudinal post-tension ducts as shown in Figure 5.9. A grout filled longitudinal joint was used as shown in Figure 5.10. The skewed panels were connected to the abutment using #8 stainless steel anchorage bars in grouted sleeves in precast panels as shown in Figure 5.11. Figure 5.12 shows the connection of the end precast panels with the paving section using a shear key and tie bar. The under-slab was filled by pumped grout to ensure adequate support. Construction challenges were aligning panels with skewed bridge floor, aligning post-tensioning ducts, and grouting operations. Photos of panel installation and encountered challenges are shown in Appendix C

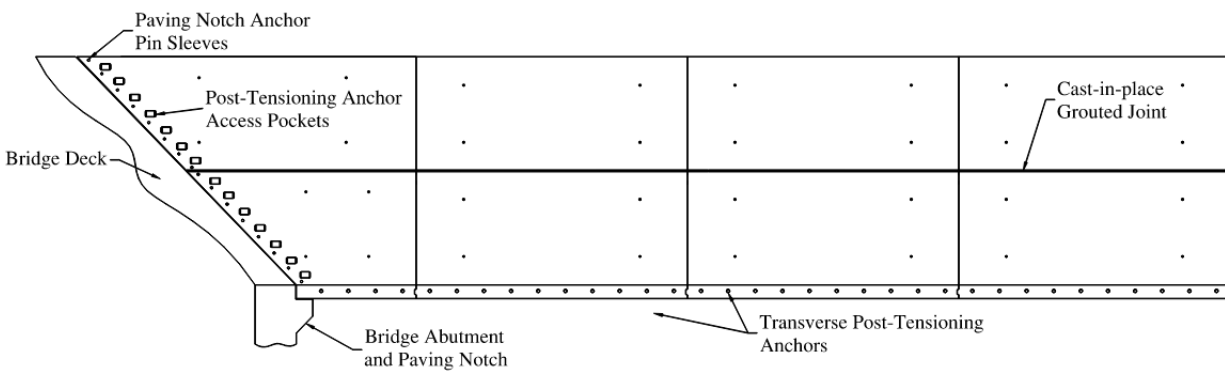


Figure 5.8: Plan view of precast post-tensioned approach slab panels (Merritt et.al, 2007)

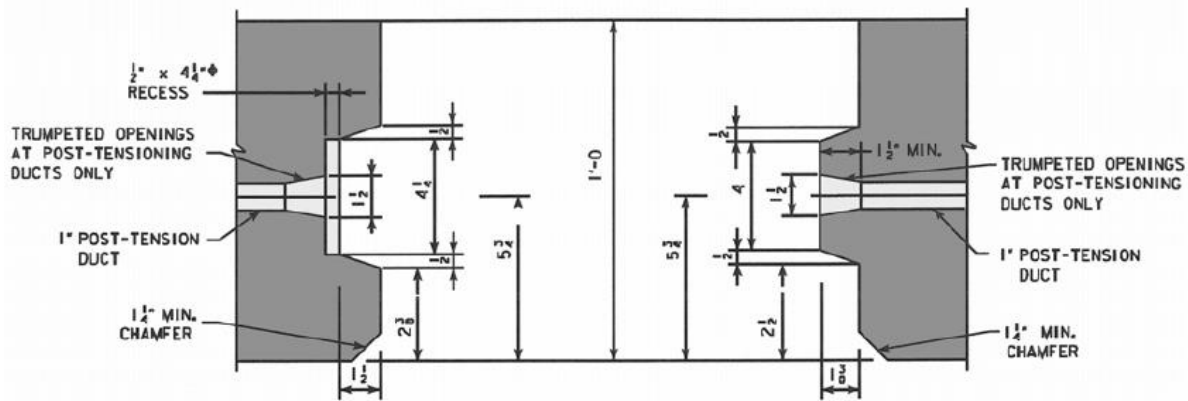


Figure 5.9: Transverse joint detail (Merritt et.al, 2007)

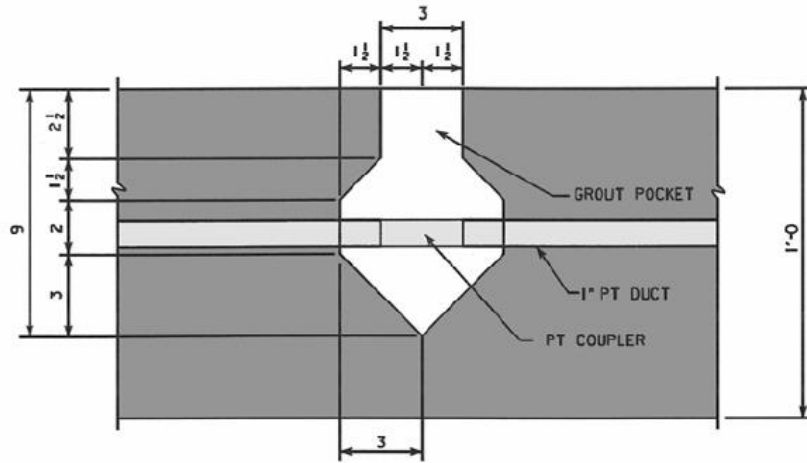


Figure 5.10: Longitudinal joint detail (Merritt et.al, 2007)

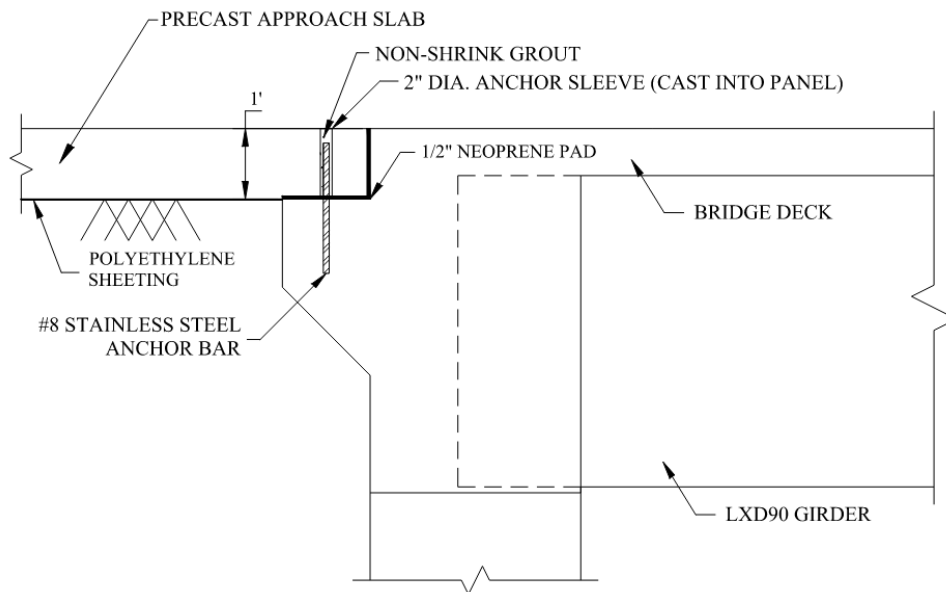


Figure 5.11: Connection to the abutment (Merritt et.al, 2007)

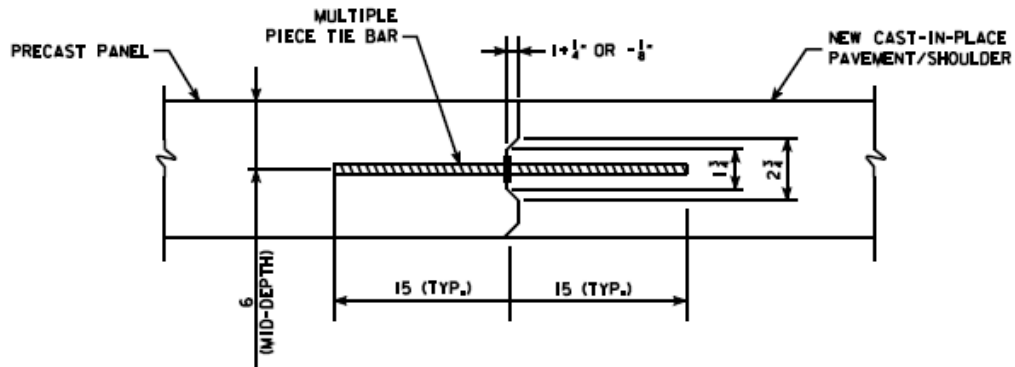


Figure 5.12: Connection to paving section (Merritt et.al, 2007)

Ziehl et.al. (2015) reported on the use of four 12 in. thick precast concrete panels to replace the approach slab of a bridge over Big Brown Creek on River Road (S-86) in Union County, South Carolina. The bridge was 37.25 ft. wide and had a skew angle of 38°. The four panels shown in Figure 5.13 were installed and monitored for long-term performance. For installation, the backfill was replaced by #789 stone and cover by a 6 in. thick roller compacted macadam as a sub-base material and polyethylene moisture barrier. Then, panels were installed starting from exterior panel by fitting the anchorage dowels of the deck ledger into the panel formed sleeves, shown in Figure 5.14, and filling the sleeves with grout. The longitudinal joints between panels had 2#6 longitudinal bars inside the overlapped #5-U shaped bars, as shown in Figure 5.15, and were filled with field-cast concrete. Precast panels were overlaid by 2.5 in asphalt layer for protection. However, separation cracks were noticed later at the joint between approach slab and pavement as shown in Appendix C.

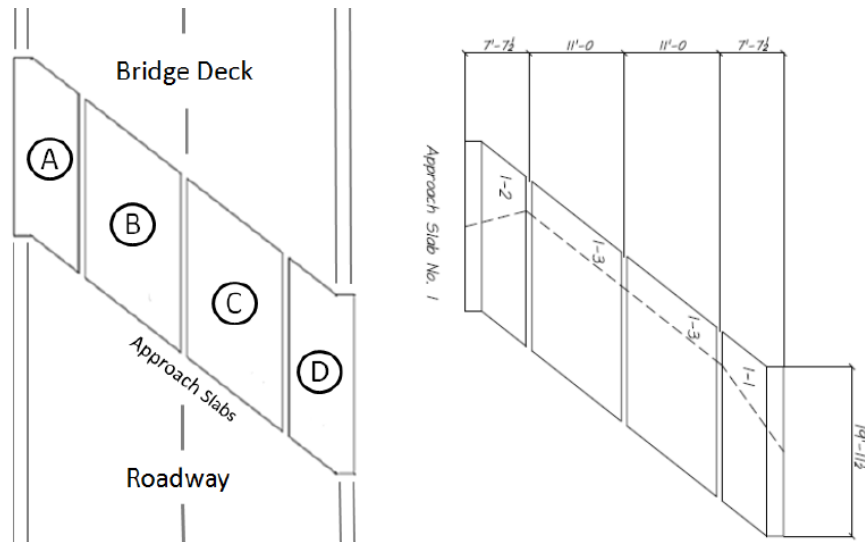


Figure 5.13: Plan view of precast concrete approach slab panels (Ziehl et.al., 2015)

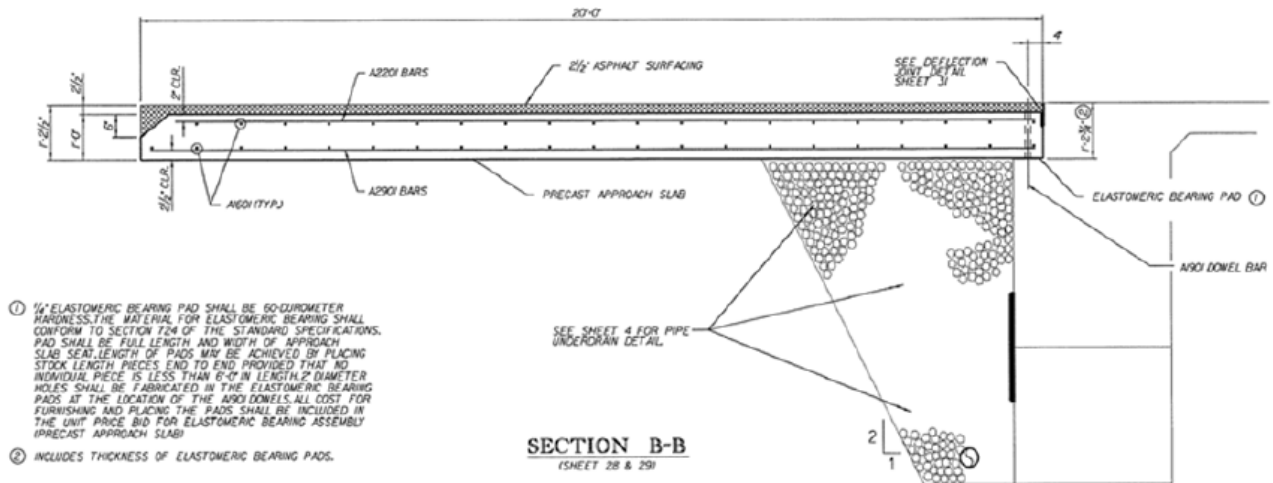


Figure 5.14: Interior panel showing formed sleeves and U bars (Ziehl et.al., 2015)

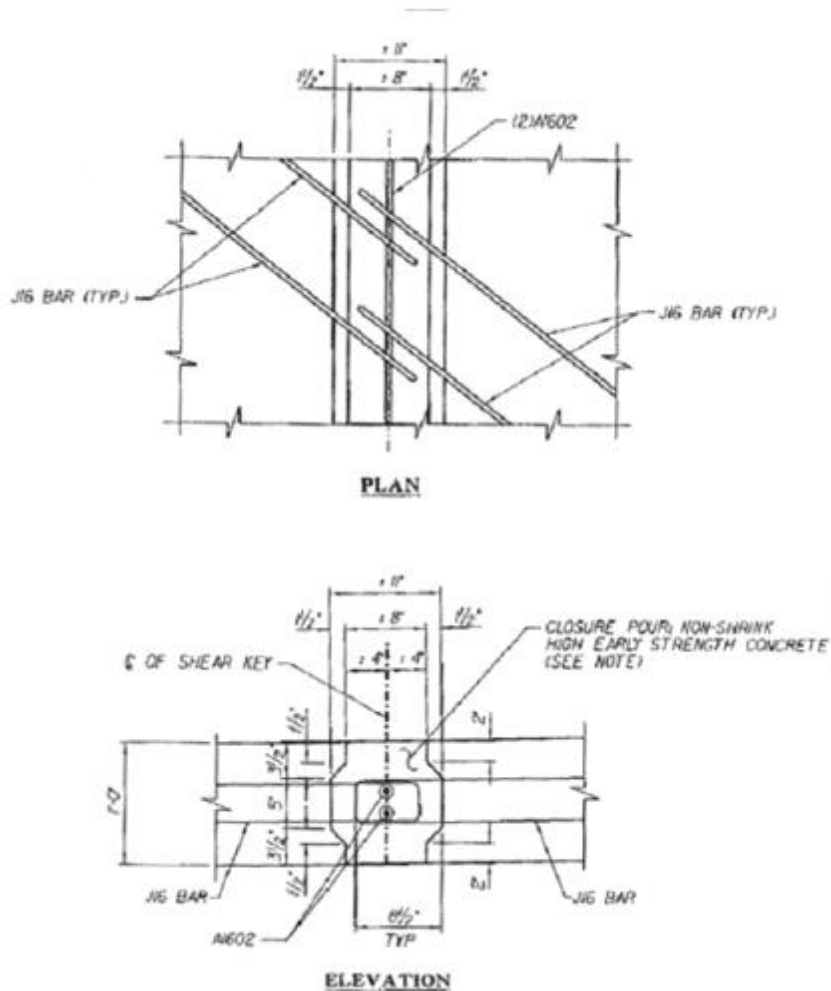


Figure 5.15: Plan and elevation views of longitudinal joint (Ziehl et al., 2015)

Gudimetla, 2012 proposed a design of precast concrete approach slab that is alternative to Missouri DOT standard design of CIP concrete approach slabs. The precast concrete slab is 12 in. thick, 25 ft long, and 38 ft wide as shown in Figure 5.16. The slab consists of several adjacent panels that are 4 ft – 6 ft wide and longitudinally prestressed using 0.5 in. diameter Grade 270 strands at 4 in. spacing as shown in Figure 5.17. The panels are connected transversely using Hollow Structural Section (HSS) and #4 rebars at 12 in. spacing, which will be field grouted after installation. Figure 5.18 shows a longitudinal section of the proposed approach slab with the connection to the abutment and sleeper slab. Another alternative is also proposed that is similar to this one but using 10 in. thick precast slab and 2 in. CIP concrete topping.

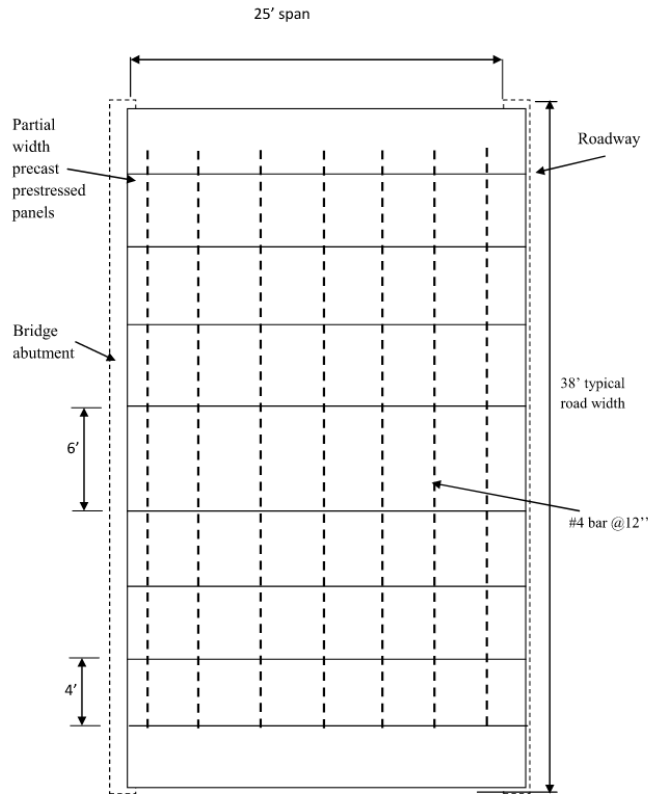


Figure 5.16: Plan view of precast approach slab panels (Gudimetla, 2012)

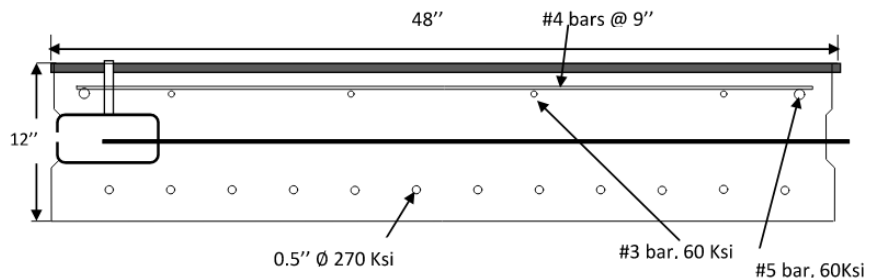


Figure 5.17: Cross section in one panel (Gudimetla, 2012)

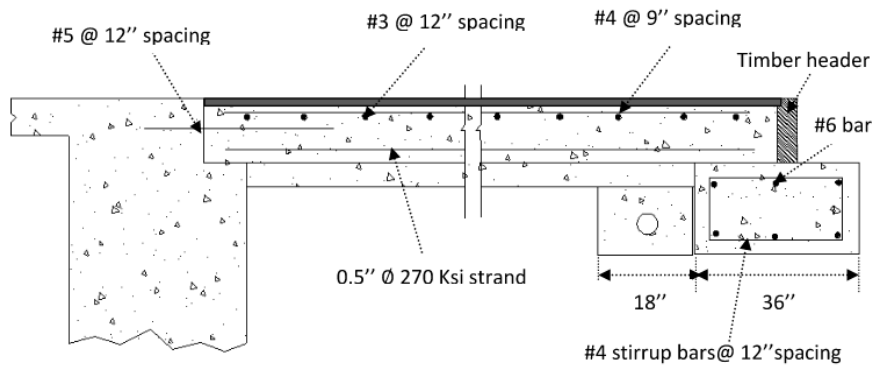


Figure 5.18: Longitudinal section of the approach slab (Gudimetla, 2012)

Illinois DOT published guidelines for precast concrete approach slabs for the following cases: no skew, less than 30 deg. skew (right and left), and greater than 30 deg. (right and left). Figure 5.19 shows the plan and section views for no skew case illustrating the connections at the abutment and at approach slab footing (i.e. sleeper slab). Figure 5.20 shows that the precast approach slab consists of several adjacent panels that are approximately 2 – 3 ft wide. Details of the longitudinal joint between panels and panel reinforcement are shown in Figures 5.21 and 5.22 respectively.

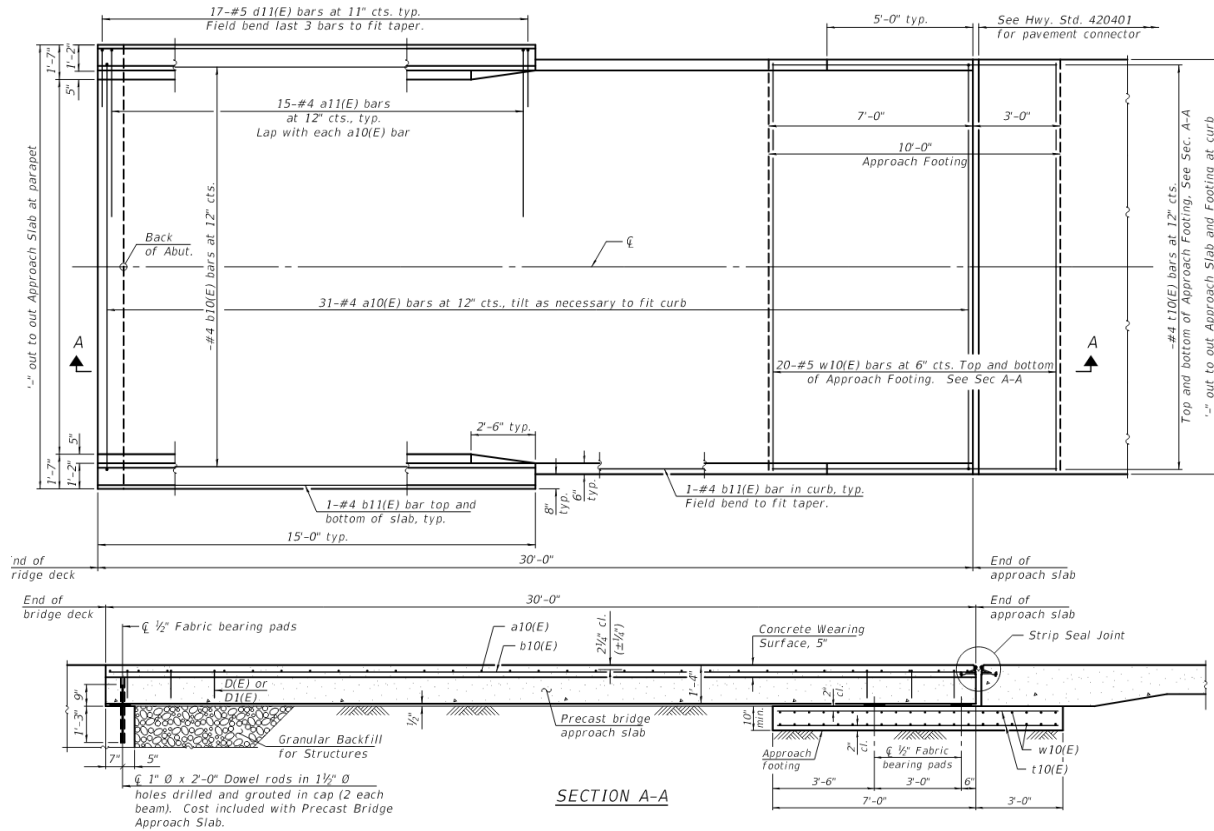


Figure 5.19: Plan and section views of approach slab with no skew (IDOT, 2017)

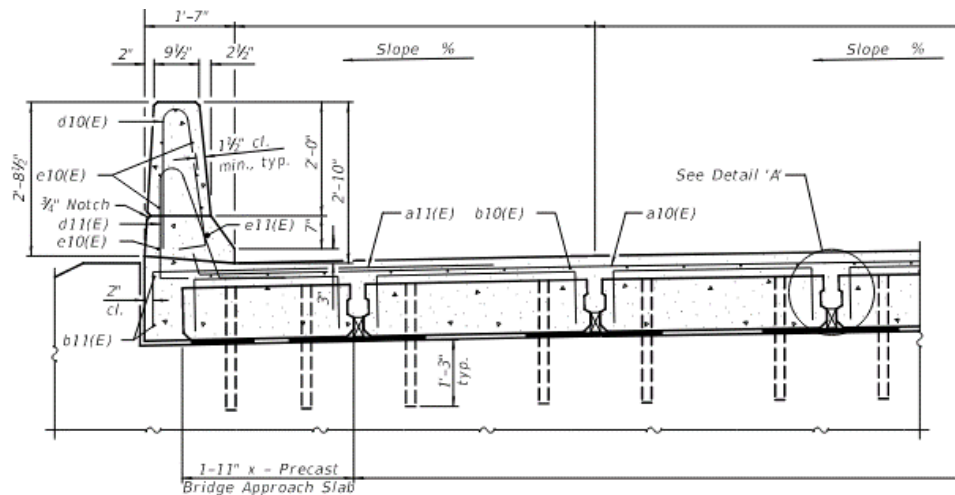


Figure 5.20: Cross section of approach slab near abutment (IDOT, 2017)

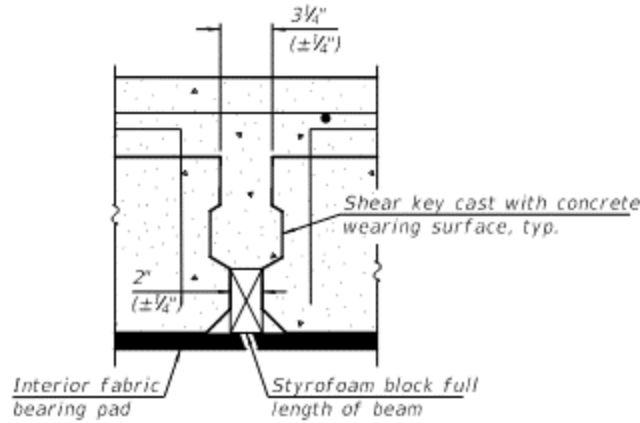


Figure 5.21: Longitudinal Joint detail A (IDOT, 2017)

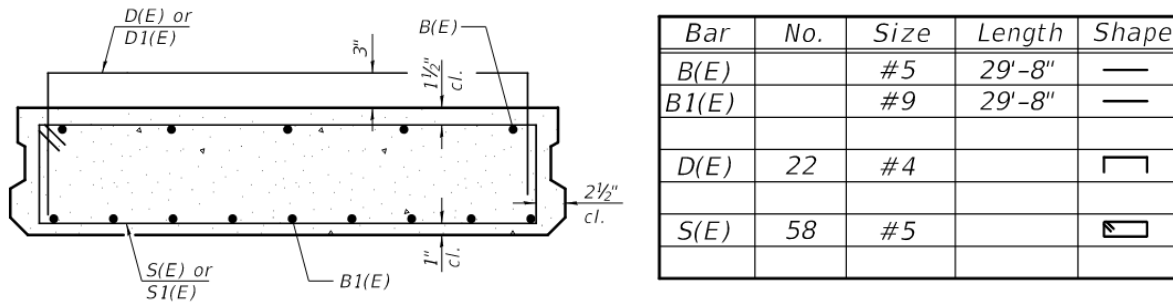


Figure 5.22: Reinforcement of precast concrete approach slab panel (IDOT, 2017)

NDOT had successfully implemented precast concrete approach slabs in two recent projects. The first project was the replacement of the Belden-Laurel bridge on U.S. 20 over Middle Logan Creek in Cedar County, NE in 2018. The project was the first bridge in Nebraska constructed entirely using prefabricated components, including approach slabs, for accelerated bridge construction (Morcoux and Tawadrous, 2021). Four full-length full-depth precast concrete panels were used to construct each of the two approach slabs of the bridge that is 42 ft. 8 in. wide with 10 degrees skew as shown in Figure 5.23. Another four panels were used to construct the paving section at each end. Longitudinal joints between panels were filled with 4 ksi High Early Strength Concrete (HESC) as shown in Figure 5.24. The end transverse joints between the panels and bridge deck, shown in Figure 5.25, were filled with Ultra-High Performance Concrete (UHPC). The paving section panels, shown in Figure 5.26, are connected to the grade beam using 1 in. diameter dowels that are embedded into 6 in. formed sleeves and filled with HESC. Flowable fill was pump underneath the paving section panels to fill the gaps between the panels and backfill. Appendix C shows construction photos as well as photos of inspection conducted on 04/09/2021 indicating transverse cracking of the asphalt overlay at the end of paving section and end of floor.

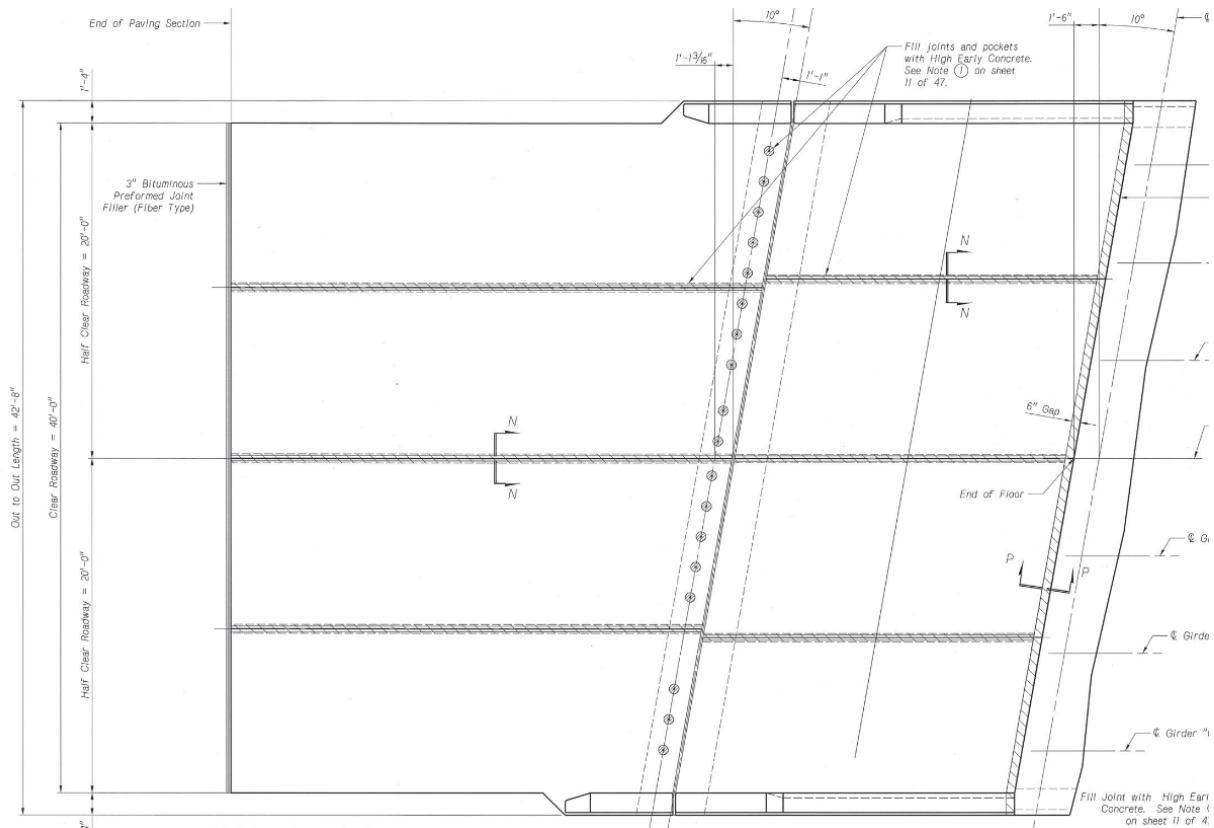


Figure 5.23: Plan view of the precast approach slab and paving section panels (Belden-Laurel Bridge)

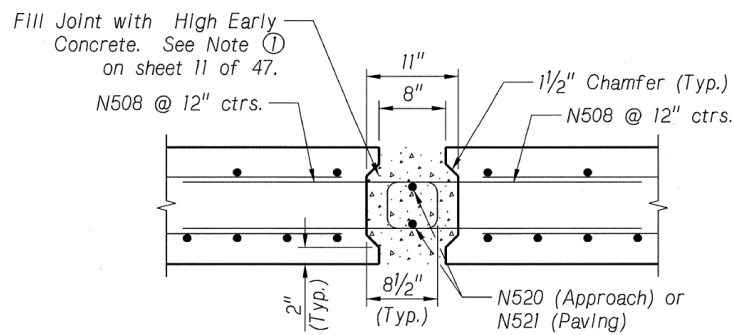


Figure 5.24: Longitudinal joint between precast concrete panels (Belden-Laurel Bridge)

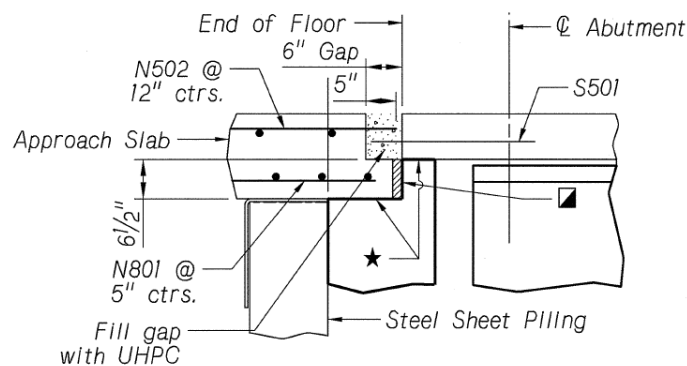


Figure 5.25: Transverse joint between precast concrete approach slab and bridge deck (Belden-Laurel Bridge)





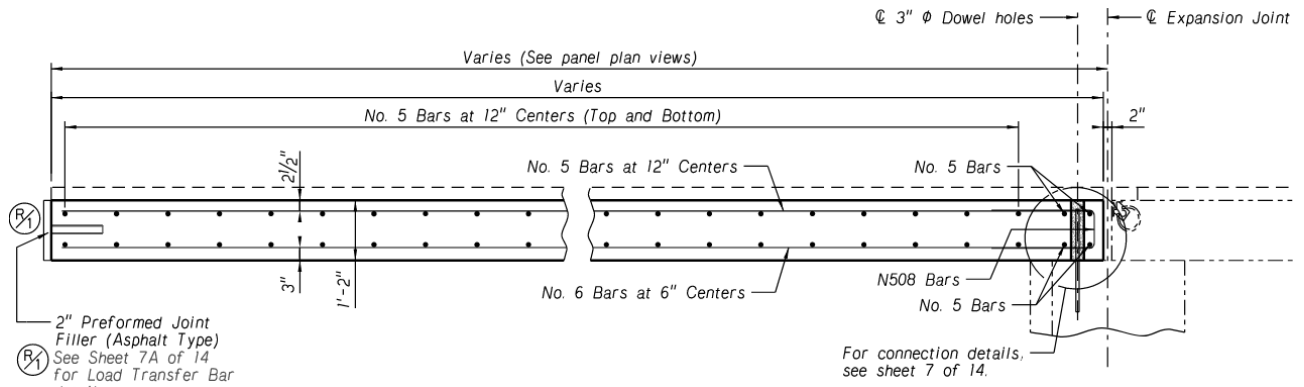


Figure 5.27: Plan and section views of an interior precast concrete panel of the paving section and its connection to the grade beam (I-680/West Center Road Bridge)

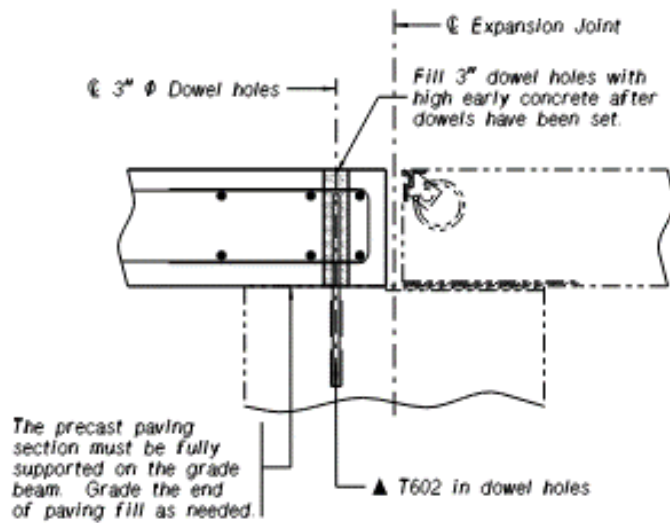


Figure 5.28: Connection of the precast concrete panel of the paving section to the grade beam (I-680/West Center Road Bridge)

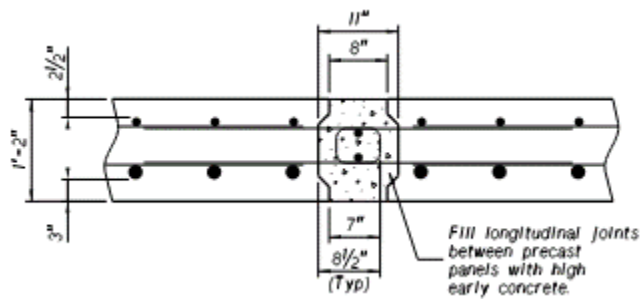


Figure 5.29: Longitudinal joints between precast concrete panels of the paving section (I-680/West Center Road Bridge)

Table 5.1 summarizes the dimensions and reinforcement of the precast prestressed (PC) and reinforcement (RC) concrete approach slabs presented earlier for ease of comparison. This table indicates that most common panel thickness is 12 in. with 4 or 5 ksi compressive strength concrete. Panels are commonly connected with HESC-filled longitudinal joints that are reinforced with #5 U-bars and either horizontal or vertical dowels to connect to the abutment. Panels can be as narrow as 4 ft and as wide as 14 ft. Top and bottom reinforcement can vary significantly in both longitudinal and transverse directions.

Table 5.1: Summary of Precast Concrete Approach Slabs

DOT	Project	Type	Length (ft)	Width (ft)	No. of Panels	Thickness (in.)	Skew (deg.)	$f_c'$ (ksi)	Bottom Reinforcement	Top Reinforcement	Longitudinal Joints	Connection to Abutment
Iowa, 2007	Highway 60 Bridge	PC	20	14	8	12	30	5	#6@2' Long. #5@2' Trans.	#6@2' Long. #5@2' Trans.	Post-Tensioned + Grout	#8@24" Vt. Dowel
Missouri, 2012	Proposal	PC	25	4	8	12	N/A	5	12-0.5" Long. Strands	#4@9" Long. #3@12" Trans.	#4@12", HSS, Grout	#5@12" Hz. Dowel
S. Carolina, 2015	Big Brown Creek Bridge	RC	20	11	4	12	38	8	#9@6" Long. #6@12" Trans.	#7@12" Long. #6@12" Trans.	#5@12"U, 2#6, 4 ksi HESC	#9@12" Vt. Dowel
Illinois, 2017	Standards	RC	30	2.67	N/A	16 (11+5)	N/A	6	#9@5" Long. #5@6" Trans.	#5@12" Long. #5@6" Trans.	Unreinforced concrete	2#8 Vt Dowels per Panel
Nebraska, 2018	Belden-Laurel Bridge	RC	20	10	4	14	10	4	#8@5" Long. #5@7.75" Trans.	#5@12" Long. #5@11.75" Trans.	#5@12"U, 2#5, 4 ksi HESC	#5@12" Hz. Dowel + UHPC
Nebraska, 2019	I-680 & W. Center Rd.	RC	30	7.33	6	14	7.25	4	#6@6" Long. #5@12" Trans.	#5@12" Long. #5@12" Trans.	#5@12"U, 2#5, 4 ksi HESC	#6@12" Vt. Dowel

Other state DOTs, such as New York State DOT (NYSDOT), provide guidelines for materials, element fabrication, and construction sequence. Examples of the guidelines for precast concrete approach slabs in NYSDOT Prestressed Concrete Construction Manual (PCCM) are:

- Use Epoxy Coated Bar Reinforcement or Stainless Steel rebars.
- Concrete Compressive Strength  $f_c' \geq 5000$  psi at 28 days, and  $f_{ci} \geq 3000$  psi at lifting.
- Maximum tensile stress in concrete due to handling and erection loads shall not exceed  $0.15\sqrt{f_{ci}}$
- Fabrication tolerances are
  - Panel Width and Length  $\pm 1/8''$
  - Overall Depth  $+ 1/8''$
  - Reinforcement cover  $+ 3/16''$
  - Horizontal alignment  $1/4''$  for  $L \leq 40$  ft.,  $3/8''$  for  $L \leq 60$  ft.,  $1/2''$  for  $L \geq 60$  ft.
- Equipment weighing more than 2500 pounds shall not be permitted on the precast panels between the initial set of the longitudinal closure pour and the time that test cylinders demonstrate the closure pour concrete has reached a minimum strength of 10 ksi.
- Surfaces shall be finished to a surface tolerance of  $1/4$  in. in 10 ft.

### 5.3 Proposed Alternatives

Based on the discussion presented earlier on the different precast concrete approach slab systems and their pros and cons, it was decided that the partial-width full-length non-prestressed concrete approach slab system is the most appropriate system for NDOT due to its simplicity, speed of construction and economy. However, some suggested changes are proposed to develop alternatives to this system, as shown in Figure 5.30, that could enhance its constructability and extend its service life. For example, using UHPC instead of HESC in both longitudinal and transverse joints, as shown in Figures 5.31 and 5.32 respectively, simplifies the reinforcement details at these joints and improves their resistance to ingress of water and chemicals. Also, replacing ASTM A615 Grade 60 epoxy-coated steel reinforcement with ASTM A1035 Grade 100 ChromX 4100 reinforcement, as shown in Figure 5.33, will allow decreasing panel thickness to 12 in. instead of 14 in., reducing amount of reinforcement needed, and increasing corrosion resistance without significant increase in cost. This is primarily due to the advantage ASTM A1035 has over ASTM A615 in stress-strain behavior as shown in Figure 5.34. Detailed calculations of these changes are resented in Appendix B. Figure 5.35 shows two section views with reinforcement details for the four alternatives presented in Figure 5.30. Figure 5.36 shows the direction of transverse reinforcement and longitudinal reinforcement as well as location of lifting points for an example 12 ft x 20 ft panel with and without skew. Although it is recommended to place the longitudinal reinforcement perpendicular to the support lines when skew angle ( $\theta$ ) is greater than 30 degrees, this could be impractical due to the small size of the panel. Therefore, it is recommended to maintain the direction of longitudinal reinforcement parallel to traffic with multiplying the amount of reinforcement by a magnification factor ( $1/\cos(\theta)$ ) to compensate for the deviation from the principal stresses' direction.

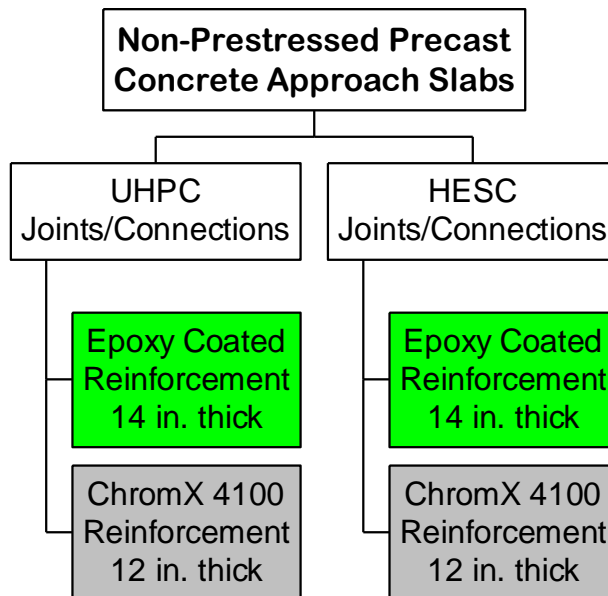
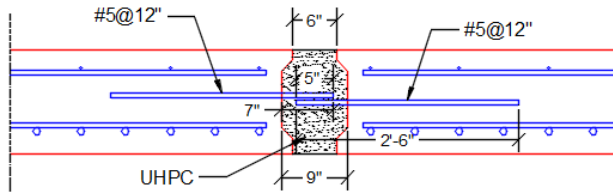
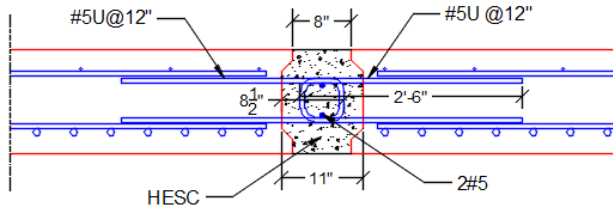


Figure 5.30: Proposed alternatives of non-prestressed precast concrete approach slabs

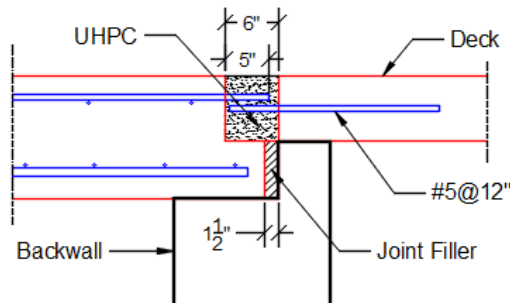


**UHPC Longitudinal Joint**

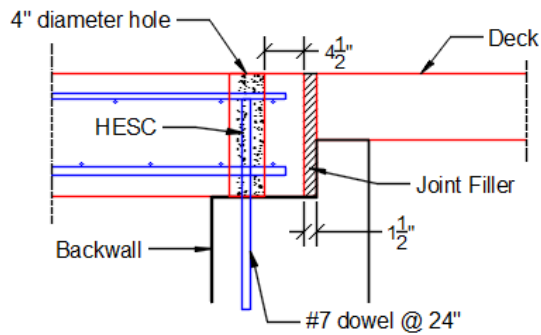


**HESC Longitudinal Joint**

*Figure 5.31: Alternatives of longitudinal joints*

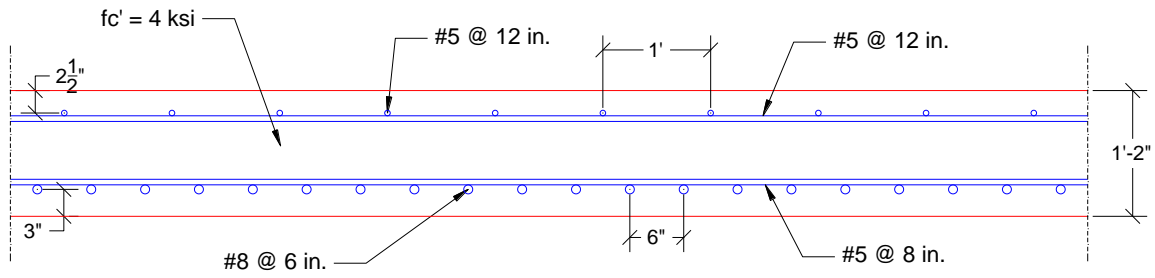


**UHPC Connection**

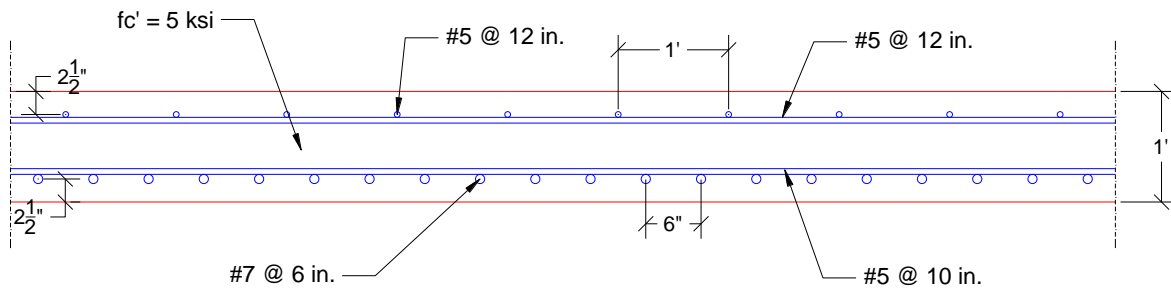


**HESC Connection**

*Figure 5.32: Alternatives of panel end connection*



**Epoxy Coated Grade 60 A615 Steel**



**ChromX 4100 Steel Grade 100 A1035 Steel**

Figure 5.33: Comparing design of precast concrete approach slab using Grade 60 A615 and Grade 100 A1035 reinforcing steel

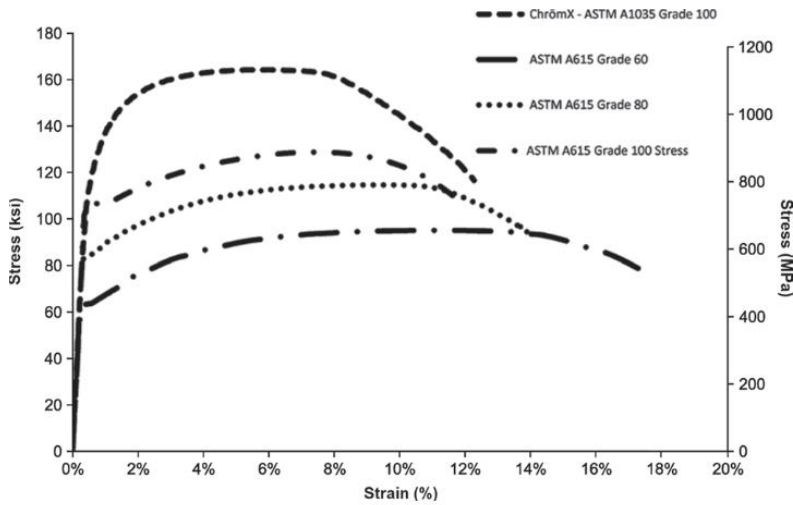


Figure 5.34: Comparison of typical stress-strain curves for ASTM A615 and ASTM A1035 reinforcement bars (ACI 439-19)

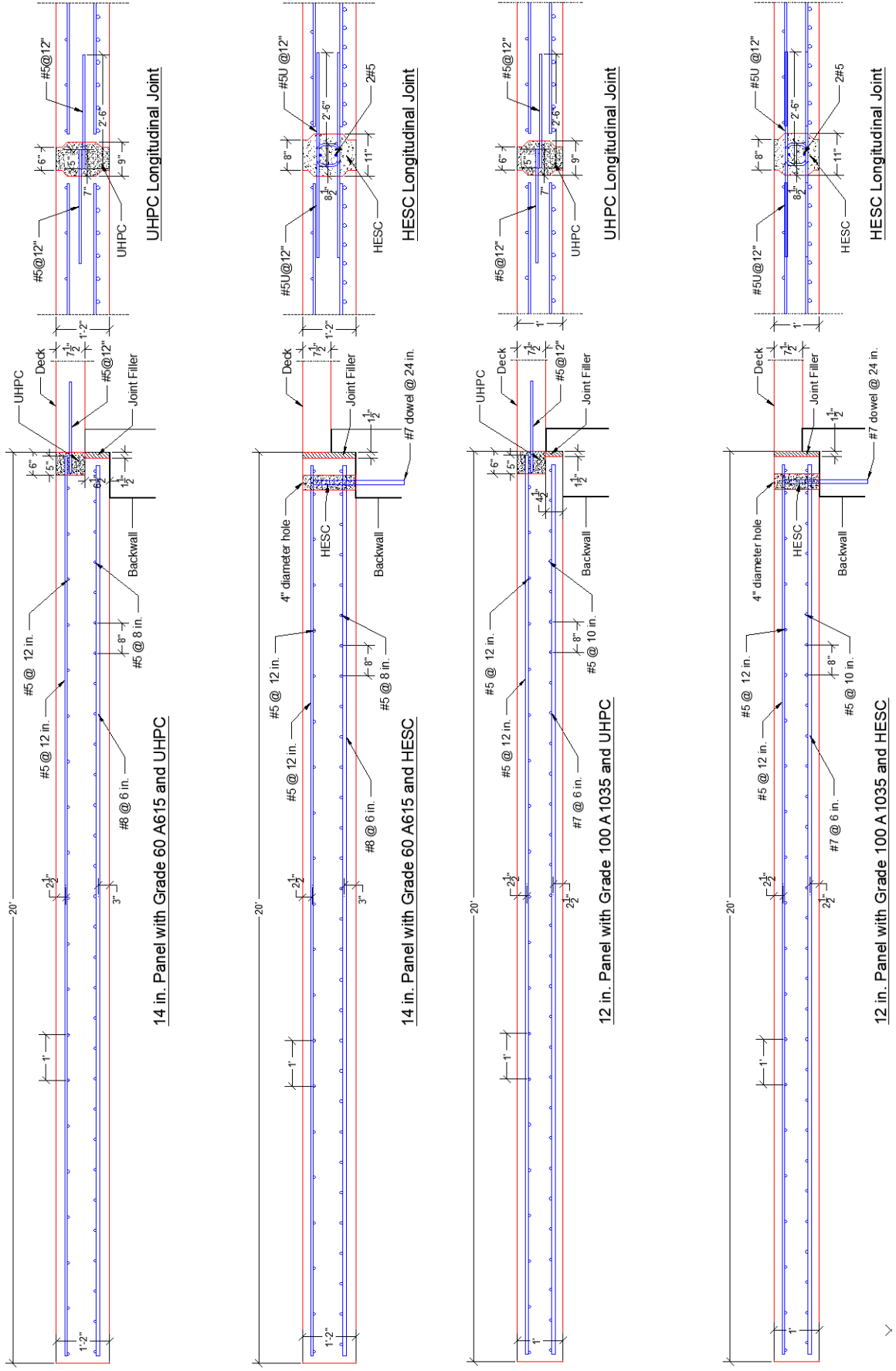


Figure 5.35: Precast concrete approach slab alternatives

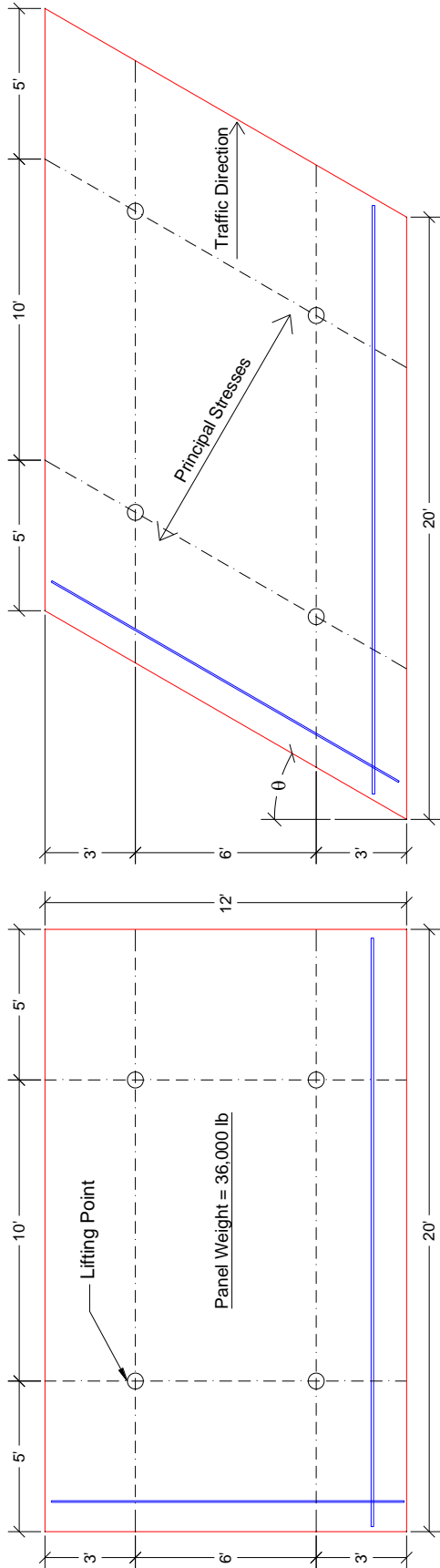


Figure 5.36: Direction of reinforcement in skewed panels



## Chapter 6. Conclusions and Lessons Learned

### 6.1. Conclusions

This report presents a literature review on the current practices of approach slab in Nebraska and the other DOTs. The causes of approach slab deterioration and its possible solutions were discussed. Also, a parametric study was conducted by finite element modelling. The following conclusions were drawn from this study:

1. The current practices for design and detailing of CIP concrete approach slabs in US differ significantly among state DOTs with respect to slab length, slab thickness, concrete cover, joints/connection, and top and bottom longitudinal and transverse reinforcement.
2. Concrete cracking and differential settlement are the top two problems with approach slabs. Using grade beam on piles, which is the current practice of NDOT, minimizes the settlement problem, however, cracking in the longitudinal direction in particular is still a common problem.
3. NDOT current CIP concrete approach slab design and detailing is sufficient for dead and live load effects. However, volume changes due to shrinkage and temperature generate high transverse tensile stresses at the abutment end due to the lateral restraints. These stresses could result in top longitudinal cracking perpendicular to the abutment support line.
4. Reducing the stiffness of the approach slab connectors to the abutment backwall, providing polyethylene sheeting under the approach slab, and using full-depth longitudinal joints in wide approach slabs are efficient methods for reducing the lateral restraints and, consequently, the transverse stresses leading to longitudinal cracking. In addition, reducing the spacing between top transverse reinforcement close to the abutment is also recommended to control the longitudinal cracking at the top surface and enhance approach slab durability.
5. In highly skewed approach slabs (skew angle greater than 30 deg.), the direction of bottom principal tensile stresses is perpendicular to the support lines. Therefore, it is recommended to change the orientation of bottom longitudinal reinforcement in this case to match the direction of principal tensile stresses for better utilization of the provided reinforcement.
6. For precast concrete approach slabs, the use of field-cast UHPC can simplify the panel-to-panel longitudinal joint and panel-to-backwall connection due to the significantly reduced development length of the bars used.
7. Replacing the ASTM A615 Grade 60 epoxy-coated steel reinforcement with ASTM 1035 Grade 100 ChromX 4100 reinforcement allows decreasing panel thickness to 12 in. instead of 14 in. and reducing amount of reinforcement needed, which enhances the cost effectiveness of the precast system. This is primarily due to the higher corrosion resistance and strength of Grade 100 ASTM A1035 over Grade 60 ASTM A615.

## 6.2. Lessons Learned

Several lessons were learned from the two NDOT projects that were constructed using precast concrete approach slabs/paving sections. These lessons reflect the experience of precasters/contractors during the fabrication and erection of the precast panels in the Belden-Laurel Bridge and I-680 and W. Center Road Bridge. Below is a summary of these lessons:

- a) Precast reinforced concrete approach slabs are simple to produce and install, however, bar tying requirements could be relaxed in precast construction from those in CIP construction due to the controlled environment and tight production tolerances.
- b) Approach slab panel joints/connections could be simplified when UHPC is used to benefit from the high strength and bond properties of UHPC in addition to its durability.
- c) Lifting inserts for panel handling should be located at the center of gravity of the panel including the rail if precast concrete rail is used. This could be significantly different in small panels.
- d) Sand blasting the joints after producing several panels could be more efficient than using retarders to expose aggregates at the edges of each panel. It does not take long time to cover the projecting bars and do sand blasting of all joints.
- e) Pumping flowable fill underneath the paving sections is very challenging especially in sloped surfaces. It works better in flatter surfaces.
- f) Flowable fill can get easily trapped at some locations making it difficult to pump. It also can seep around joints making it difficult to fill the joints with concrete and push the flowable fill away.
- g) Other alternatives to pumping flowable fill are compacting the base properly or using leveling bolts to create enough gap for easier flow of pumped fill.
- h) Leaving PVC tubes in the dowel holes makes it difficult to remove later. The PVC tubes should be removed early on to ensure adequate bond with the fill concrete/grout.
- i) Using dry mix to fill dowel holes is challenging. Using grout or flowable mix is more efficient.
- j) Threading two #5 bars inside the overlapped U-shaped loop bars of the longitudinal joints between adjacent panel is challenging. This could be simplified by having one #5 bar inside each loop bar prior to installing the panel.

## REFERENCES

- Abo Elkhier, M., and Morcous, G., 2020. "Design and Detailing of Bridge Approach Slabs: Cast-in-Place and Precast Concrete Options", Sustainable Issues in Infrastructure Engineering, Springer, December.
- American Association of State Highway and Transportation Officials (AASHTO). 2017. "LRFD Bridge Design Specifications." AASHTO LRFD, 8th Edition, AASHTO, Washington, D.C.
- American Concrete Institute (ACI) Committee 439, 2019 "Guide for the Use of ASTM A1035/A1035M Type CS Grade 100 Steel Bars for Structural Concrete", Farmington Hills, MI
- California Department of Transportation (Caltrans). 2018. Standard Plans Book. California, USA
- Chee, M.M.W. (2018). Assessment of Structural Concrete Approach Slab Cracking at Integral Abutment Bridges. Masters' Thesis. University of Illinois at Urbana-Champaign, Urbana, Illinois.
- Colorado Department of Transportation (CDOT). 2020. Bridge Design Manual. Colorado, USA.
- Gudimetla, B. 2012, "Precast Prestressed Bridge Approach Slab – Cost Effective Designs", Thesis, University of Missouri-Columbia.
- Illinois Department of Transportation (IDOT), 2017 "Bridge Approach Slab – Precast", Springfield, IL.
- Iowa Department of Transportation (Iowa DOT). 2020. LRFD Bridge Design Manual. Iowa, USA.
- King, D. 2020. "Jointing Basics for Concrete Pavement", 56<sup>th</sup> Iowa Concrete Paving Workshop, Iowa Concrete Paving Association (ICPA), February.
- Merritt, D.K., Miron, A.J., Rogers, R.B., and Rasmussen, R.O. 2007. "Construction of the Iowa Highway 60 Precast Prestressed Concrete Pavement Bridge Approach Slab Demonstration" Report No. FHWA-IF-07-034, USDOT, FHWA, Washington, DC.
- Missouri Department of Transportation (MoDOT), 2020, "Bridge Standard Drawings, Approach Slabs – APP", Jefferson City, MO
- Morcous G., and Tawadrous R., 2021. "Circular Shear Pocket Connection for Full-Depth Precast Concrete Deck Construction", ASCE Journal of Bridge Engineering, 26(5).
- Nebraska Department of Transportation (NDOT). 2016. Bridge Office Policies and Procedures (BOPP) Manual, Lincoln, NE.
- Nebraska Department of Transportation (NDOT). 2018. Bridge Inspection Program Manual, Lincoln, NE.
- New York State Department of Transportation (NYSDOT), 2017. "Prestressed Concrete Construction Manual (PCCM)", Office of Structures, April, Albany, NY.
- Precast/Prestressed Concrete Institute (PCI), 2012. "Guideline for Precast Approach Slab", Chicago, IL.

- Thiagarajan, G., Gopalaratnam, V., Halmen, C., Ajgaonkar, S., Ma, S., Gudimetla, B., and Chamarthi, R. (2010). Bridge Approach Slabs for Missouri DOT: Looking at Alternative and Cost Efficient Approaches. Report No. OR11.009, Missouri Department of Transportation, Jefferson City, MO
- Washington State Department of Transportation (WSDOT). 2019. "Design - Standard Plans Manual", Olympia, WA.
- Ziehl, P., ElBatanouny, M., and Jones, M.K. 2015. "In-situ Monitoring of Precast Concrete Approach Slab Systems" South Carolina Department of Transportation (SCDOT), Columbia, SC.

## APPENDIX A: Proposed Specifications

### 2.2.4 – Approach Slab Policy

#### General Design

Approach slabs will be required on all State projects. Plans and elevation views of approach sections should be shown on the General Plan and Elevation Sheet of Bridge Plans.

For bridges that are to be widened, the existing bridge and location should be investigated to determine any deviations from the standard approach layout.

#### Design Criteria

##### Approach Section

The approach section length shall be 20 ft. from the end of the bridge floor to CL grade beam; see Grade Beam Policy for more information. The thickness of cast-in-place concrete approach section shall be 14 in. and can be reduced to 12 in. for precast construction if higher steel grades are used. The approach section reinforcing details shall be as shown in Section 6 (6.12 thru 6.14), Approach Slab Base Sheets. Approach slabs are placed above the abutment wing; see Wing Policy for more information.

##### Paving Section

The paving section length shall be 30 ft. from CL grade beam to the road pavement along CL clear roadway. The joint between the paving section and the roadway shall be perpendicular to CL roadway. For wide bridges and/or large skew angles, Designers shall consult with the Assistant Bridge Engineer on a case-by-case basis.

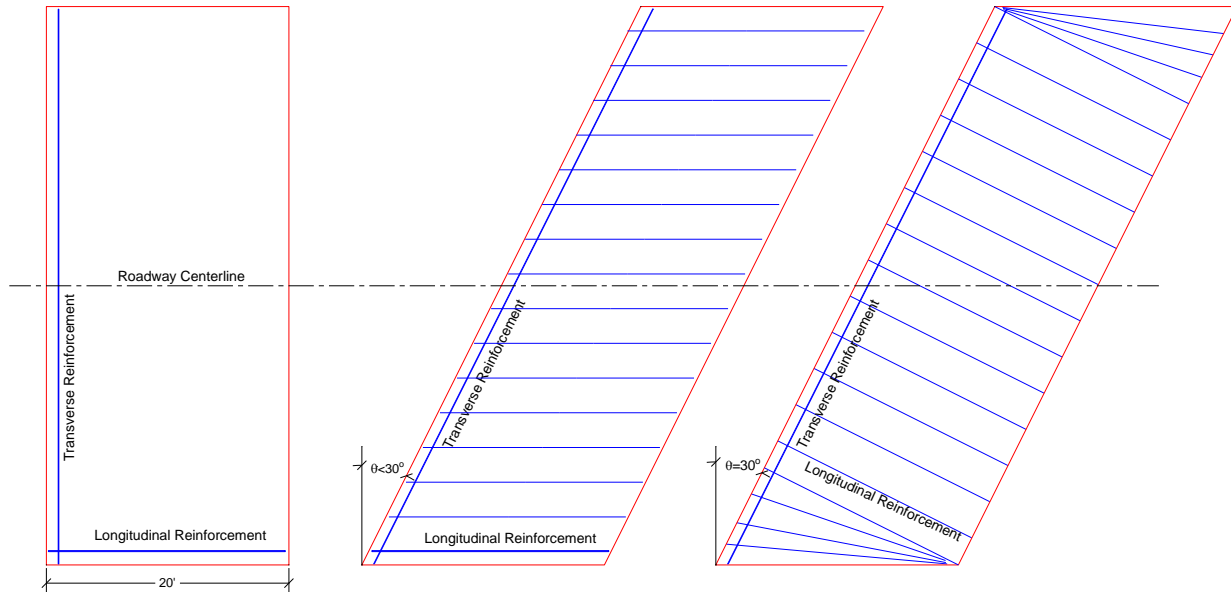
The thickness of cast-in-place concrete paving section shall be 14 in. and can be reduced to 12 in. for precast construction. The reinforcing details shall be as shown in Section 6 (6.12 thru 6.14), Approach Slab Base Sheets.

If abutment wings extend beyond the grade beam, changing paving section layouts is not recommended. Designers shall show elevations of the end of pavement sections at left edge, center and right edge.

##### Reinforcement Layout

For slabs with skew angle less than 30 degrees, longitudinal bar spacing is measured perpendicular to CL roadway and placement is parallel to the CL roadway. For slabs with skew angle greater than or equal to 30 degrees, longitudinal bars spacing is measured parallel to the skewed support lines and placement is perpendicular to the skewed support lines as shown below. Designers should

check longitudinal bar lengths to verify if the skew dictates a shorter bar. Field personnel indicated that omission of these slight skew adjustments have caused problems for joint installation. Transverse bar spacing is always measured parallel to CL roadway and placement is always parallel to skewed support lines as shown below.



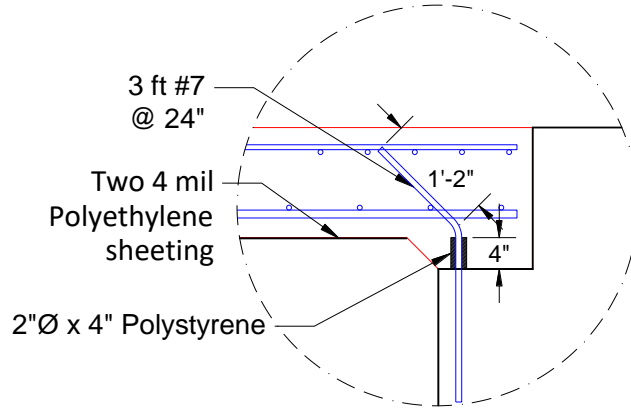
*Reinforcement Layout in Approach Slabs*

### **Polyethylene sheeting under concrete approach slab**

Provide 2 layers 4 mil Polyethylene sheeting CLASS A under the approach slab as shown on the plans. Polyethylene sheeting shall conform and be tested to a standard ASTM E1745, which is the standard for vapor retarders in contact with soil or granular fill used under concrete slabs. These materials should be engineered not to decay in this type of application. Soil or granular fill shall be compacted and leveled as required prior to placing the polyethylene sheeting. Polyethylene sheeting is used to reduce the friction forces between the approach slab and subbase. The top surface of the grade beams shall be troweled smooth and polyethylene sheeting is laid over as a bond breaker between the approach slabs and grade beams.

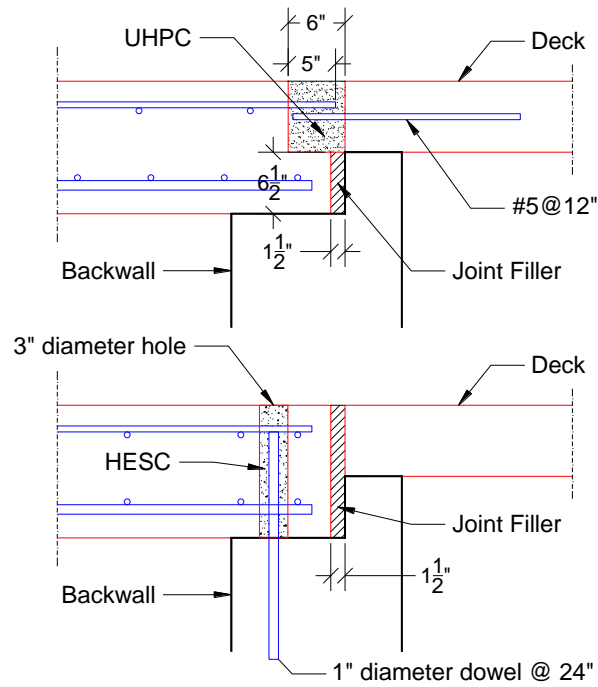
### **Approach Slab Connection at the Abutment End**

For cast-in-place concrete approach slabs, provide 2 in. diameter and 4 in. long polystyrene sleeve on #7 dowels at 24 in. spacing connecting the approach slab to the backwall as shown below.



*CIP Approach Slab Connection at Abutment*

For precast concrete approach slabs, two options are available for connecting the panels to the deck/backwall using ultra-high performance concrete (UHPC) and high-early strength concrete (HESC) as shown below.



*Precast Approach Slab Connection Alternatives at Abutment*

## Roadway Joint

When the roadway is concrete pavement, use 3 in. joint filler (Fiber Type) topped with ½ in. joint sealant and 1 ½ in. x 18 in. smooth tie bars at 12 in. centers. When the roadway is asphalt, no joint is required.

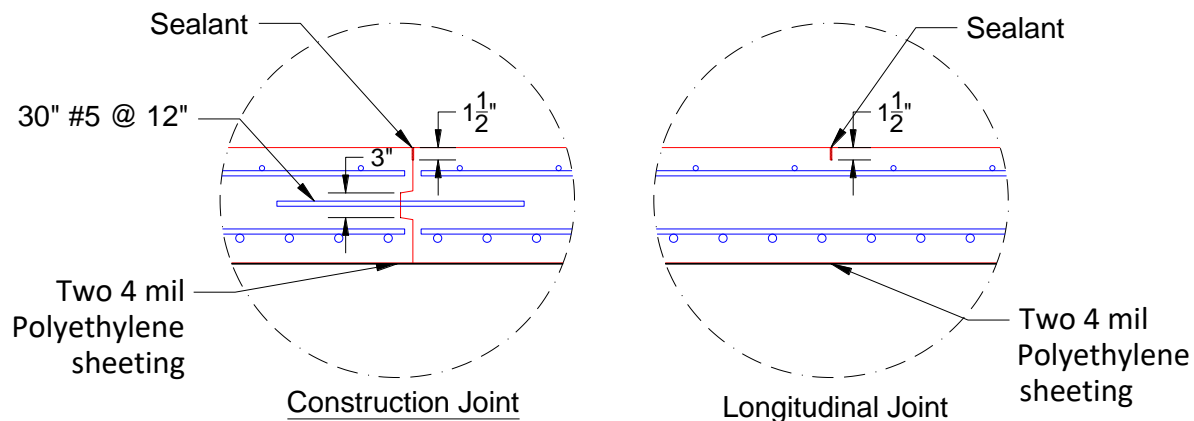
## Expansion Joint

Joint systems will be placed between the approach section and paving section in the approach slab. For information on approved expansion joint systems, see Section 3.1.7, Expansion Device Policy.

Two layers of SBS Modified Asphaltic Base Sheet placed on a steel troweled smooth surface will provide a bond breaker for bridge expansion between the approach section and the grade beam.

## Longitudinal Joints

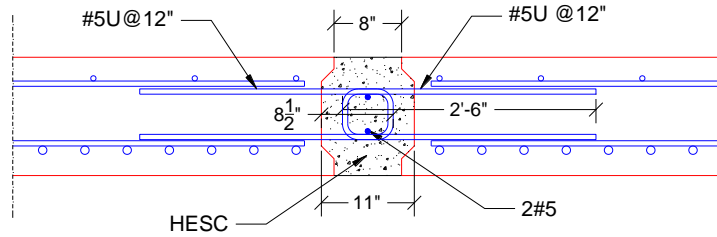
Cast-in-place concrete approach and paving sections of bridge approaches should have a full-depth construction joint, as shown below, placed at the centerline of the roadway or phase line if not phased about the centerline. On approaches where half the clear roadway exceeds 21 ft., additional longitudinal joints, as shown below, shall be placed at the edges of the 12' traffic lanes. Bridge Designers should check with the Roadway Designer for the location of the traffic lanes. The minimum spacing from the last joint to outside edge of approach should not be less than 10 ft.



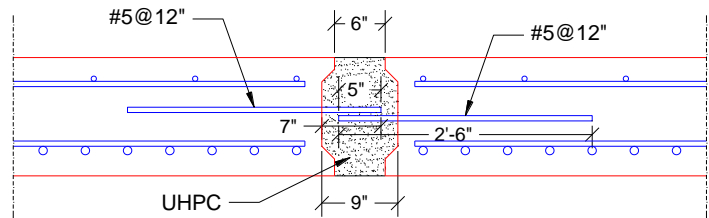
### CIP Approach Slab Construction and Longitudinal Joints

Precast concrete approach and paving sections of bridge approaches should have longitudinal joints between precast panels as shown below. Two options are provided using ultra-high performance concrete (UHPC) and high-early strength concrete (HESC).





**HESC Longitudinal Joint**



**UHPC Longitudinal Joint**

***Precast Approach Slab Longitudinal Joint Alternatives***

**Payment**

The Pay Items “Concrete for Pavement Approaches Class 47BD-4000” (CY) and “Epoxy Coated Reinforcing Steel for Pavement Approaches” (LB) includes all concrete and steel for placement of the paving and approach sections, and all rail attached to the approaches.

**Bridge Base Sheets**

There is one reference file available for the approaches; (see Section 6). Zero, RHB, and LHB skews are shown on Sheets A, B, and C, respectively (Section 6.12 thru 6.14).

**2.4.1 – Concrete Reinforcement Policy**

**Bar Clearance**

The minimum clearance, in inches, measured from the face of the concrete to the surface of any reinforcing bar will be as follows:

Approach slabs: Top of slab =  $2\frac{1}{2}'' + \frac{1}{4}'' - 0''$

Bottom of slab = 3'' for concrete slabs with A615 Grade 60 steel and  $2\frac{1}{2}''$  for concrete slabs with A1035 Grade 100 Steel.

## **APPENDIX B: Design Calculations**

Design of 14 in. Thick CIP Concrete Approach Slab Reinforced with A615 Grade 60 Steel

Design of 12 in. Thick Precast Concrete Approach Slab Reinforced with A1035 Grade 100 Steel

## **Design of Reinforced CIP Concrete Approach Slab According to AASHTO LRFD (2017)**

### **Concrete Parameters**

Concrete Compressive Strength	$f'_c := 4 \text{ ksi}$
Concrete Unit Weight	$w_c := 145 \text{ pcf}$
Aggregate Correction Factor	$K_1 := 1.0$
Normal Weight Concrete MOE	$E_c := 120000 \text{ ksi} \cdot K_1 \cdot \left(\frac{w_c}{1000 \text{ pcf}}\right)^2 \cdot \left(\frac{f'_c}{\text{ksi}}\right)^{0.33} = 3987 \text{ ksi}$
Lightweight Factor	$\lambda := \text{if}\left(w_c \leq 100 \text{ pcf}, 0.75, \text{if}\left(w_c \geq 135 \text{ pcf}, 1, 7.5 \cdot \frac{w_c}{1000 \text{ pcf}}\right)\right) = 1$
Normal Weight Concrete MOR	$f_r := 0.24 \cdot \lambda \cdot \sqrt{f'_c \cdot \text{ksi}} = 0.48 \text{ ksi}$
Concrete Ultimate Strain	$\varepsilon_{cu} := 0.003$
Design Strip Width	$b := 1 \text{ ft}$
Slab Thickness	$h := 14 \text{ in}$
Section Area	$A := b \cdot h = 168 \text{ in}^2$
Section Modulus	$S_b := \frac{b \cdot h^2}{6} = 392 \text{ in}^3$

### **Reinforcement Parameters**

Reinforcing Steel Yield Strength	$f_y := 60 \text{ ksi}$
Steel Modulus of Elasticity	$E_s := 29000 \text{ ksi}$
Steel Yield Strain	$\varepsilon_y := \frac{f_y}{E_s} = 0.002$
Area of Long. Bot. Reinforcement	$A_s := 0.79 \text{ in}^2 \cdot \frac{b}{6 \text{ in}} = 1.58 \text{ in}^2$ #8@6"
Depth of Long. Bot. Reinforcement	$d := h - 3.5 \text{ in} = 10.5 \text{ in}$
Area of Long. Top Reinforcement	$A_s' := 0.31 \text{ in}^2 \cdot \frac{b}{12 \text{ in}} = 0.31 \text{ in}^2$ #5@12
Depth of Long. Top Reinforcement	$d' := 2.5 \text{ in}$

### Flexural Strength Calculations

Stress Block Factor 1	$\beta_1 := \min \left( 0.85, \max \left( 0.65, 0.85 - \left( \frac{f'_c}{\text{ksi}} - 4 \right) \cdot 0.05 \right) \right) = 0.85$
Stress Block Factor 2	$\alpha_1 := \max \left( 0.75, \min \left( 0.85, 0.85 - \left( \frac{f'_c}{\text{ksi}} - 10 \right) \cdot 0.02 \right) \right) = 0.85$
Initial Assumptions	$f_s := f_y \quad f'_s := f_y$
Neutral Axis Distance from Extreme Compression Fibers	$c := \frac{A_s \cdot f_s - A'_s \cdot f'_s}{\alpha_1 \cdot f'_c \cdot \beta_1 \cdot b} = 2.2 \text{ in}$
Check Strain in Tension Steel	$\varepsilon_s := \frac{d - c}{c} \cdot \varepsilon_{cu} = 0.011$
Check Strain in Compression Steel	$\varepsilon'_s := \frac{c - d'}{c} \cdot \varepsilon_{cu} = -0.0004$
Stress in Tension Steel	$f_s := \mathbf{if} \left( \varepsilon_s < \varepsilon_y, E_s \cdot \varepsilon_s, f_y \right) = 60 \text{ ksi}$
Stress in Compression Steel	$f'_s := \mathbf{if} \left( \left  \varepsilon'_s \right  < \varepsilon_y, E_s \cdot \varepsilon'_s, f_y \cdot \frac{\varepsilon'_s}{\left  \varepsilon'_s \right } \right) = -12 \text{ ksi}$
Neutral Axis Distance from Extreme Compression Fibers	$c := \frac{A_s \cdot f_s - A'_s \cdot f'_s}{\alpha_1 \cdot f'_c \cdot \beta_1 \cdot b} = 2.84 \text{ in}$
Depth of Compression Block	$a := \beta_1 \cdot c = 2.41 \text{ in}$
Nominal Flexural Strength	$M_n := A_s \cdot f_s \cdot \left( d - \frac{a}{2} \right) - A'_s \cdot f'_s \cdot \left( d' - \frac{a}{2} \right) = 73.8 \text{ kip} \cdot \text{ft}$
Strength Reduction Factor for RC	$\phi_f := \min \left( 0.9, \max \left( 0.65, 0.65 + 0.25 \cdot \frac{\varepsilon_s - \varepsilon_y}{0.005 - \varepsilon_y} \right) \right) = 0.9$
Design Flexural Strength	$M_r := \phi_f \cdot M_n = 66.4 \text{ kip} \cdot \text{ft}$
Cracking Moment	$M_{cr} := S_b \cdot f_r = 15.7 \text{ kip} \cdot \text{ft}$

### Demand Calculations

Approach Slab Span	$L := 20 \text{ ft}$
Approach Slab Width	$W := 46.67 \text{ ft}$
Skew Angle	$\theta := 0 \text{ deg}$
Reduction of Longitudinal Effects	$r := \min \left( 1, 1.05 - 0.25 \cdot \tan(\theta) \right) = 1$
Barrier/Rail Weight	$w_r := 0.45 \text{ klf}$

Dead Load	$w_d := 150 \text{ pcf} \cdot h \cdot b + \frac{2 \cdot w_r}{W} \cdot b = 0.194 \text{ klf}$
Dead Load Moment	$M_d := w_d \cdot \frac{L^2}{8} = 9.71 \text{ kip} \cdot \text{ft}$
Critical Shear Section Distance	$x := 12 \text{ in} + \frac{d}{2} = 17.25 \text{ in}$
Dead Load Shear	$V_d := w_d \cdot \left( \frac{L}{2} - x \right) = 1.664 \text{ kip}$
Future Wearing Surface Load	$w_s := 25 \text{ psf} \cdot b = 0.025 \text{ klf}$
Future Wearing Surface Moment	$M_s := w_s \cdot \frac{L^2}{8} = 1.25 \text{ kip} \cdot \text{ft}$
Future Wearing Surface Shear	$V_s := w_s \cdot \left( \frac{L}{2} - x \right) = 0.21 \text{ kip}$
Lane Load	$w_{lane} := 64 \text{ psf} \cdot b = 0.064 \text{ klf}$
Lane Load Moment	$M_{lane} := w_{lane} \cdot \frac{L^2}{8} = 3.2 \text{ kip} \cdot \text{ft}$
Lane Load Shear	$V_{lane} := w_{lane} \cdot \left( \frac{L}{2} - x \right) = 0.548 \text{ kip}$
Tandem Load Moment per Lane	$M_{tandem} := 25 \text{ kip} \cdot \frac{(L - 4 \text{ ft})}{2} = 200 \text{ kip} \cdot \text{ft}$
Tandem Load Shear per Lane	$V_{tandem} := 50 \text{ kip} - 50 \text{ kip} \cdot \frac{x}{L} - \frac{100 \text{ kip} \cdot \text{ft}}{L} = 41.4 \text{ kip}$
Equivalent Width (one lane)	$E_1 := 10 \text{ in} + \frac{5 \cdot \sqrt{\min(L, 60 \text{ ft}) \cdot \min(W, 30 \text{ ft})}}{12} = 132 \text{ in}$
Number of Design Lanes	$N_L := \text{trunc} \left( \frac{W}{12 \text{ ft}} \right) = 3$
Equivalent Width (multiple lanes)	$E_2 := \min \left( 84 \text{ in} + \frac{1.44 \cdot \sqrt{\min(L, 60 \text{ ft}) \cdot \min(W, 60 \text{ ft})}}{12}, \frac{W}{N_L} \right) = 128 \text{ in}$
Service Moment	$M_a := M_d + M_s + M_{lane} + \frac{b \cdot r \cdot 1.33 \cdot M_{tandem}}{\min(E_1, E_2)} = 39.1 \text{ kip} \cdot \text{ft}$
	$check := \text{if} (M_a > M_{cr}, \text{"Cracked Section"}, \text{"Uncracked Section"}) = \text{"Cracked Section"}$
	Cracking-to-Applied Ratio $R := \frac{M_{cr}}{M_a} = 0.4$
Ultimate Moment	$M_u := 1.25 \cdot M_d + 1.5 \cdot M_s + 1.75 \cdot \left( M_{lane} + \frac{b \cdot r \cdot 1.33 \cdot M_{tandem}}{\min(E_1, E_2)} \right) = 63.3 \text{ kip} \cdot \text{ft}$
	$check := \text{if} (M_u > M_r, \text{"Inadequate Section"}, \text{"Adequate Section"}) = \text{"Adequate Section"}$

Flexure Capacity-to-Demand Ratio

$$CD := \frac{M_r}{M_u} = 1.05$$

Ultimate Shear

$$V_u := 1.25 \cdot V_d + 1.5 \cdot V_s + 1.75 \cdot \left( V_{lane} + \frac{b \cdot r \cdot 1.33 \cdot V_{tandem}}{\min(E_1, E_2)} \right) = 12.4 \text{ kip}$$

### Shear Strength Calculations

Factor of concrete ability to transmit shear  $\beta := 2$

For h less than 16 in.

Nominal Shear Resistance of Concrete  $V_c := 0.0316 \cdot \beta \cdot \lambda \cdot \sqrt{f'_c \cdot \text{ksi}} \cdot b \cdot d = 15.9 \text{ kip}$

Strength Reduction Factor for Shear  $\phi_v := 0.9$

check := if ( $V_u > \phi_v \cdot V_c$ , "Inadequate Section", "Adequate Section") = "Adequate Section"

Capacity-to-Demand Ratio

$$CD := \frac{\phi_v \cdot V_c}{V_u} = 1.16$$

### Deflection Calculations

Modular Ratio

$$n := \frac{E_s}{E_c} = 7.27$$

Location of Neutral Axis  $x := \text{root} \left( \frac{b \cdot x^2}{2} + A_s' \cdot (n-1) \cdot (x-d') - A_s \cdot n \cdot (d-x), x, 0, h \right) = 3.58 \text{ in}$

Cracked Section Moment of Inertia  $I_{cr} := \frac{b \cdot x^3}{3} + A_s \cdot n \cdot (d-x)^2 + A_s' \cdot (n-1) \cdot (x-d')^2 = 736 \text{ in}^4$

Gross Moment of Inertia

$$I_g := \frac{b \cdot h^3}{12} = 2744 \text{ in}^4$$

Effective Moment of Inertia

$$I_e := R^3 \cdot I_g + (1 - R^3) \cdot I_{cr} = 866 \text{ in}^4$$

Dead Load Deflection

$$\Delta_d := \frac{5 \cdot (w_d + w_s) \cdot L^4}{384 \cdot E_c \cdot I_g} = 0.07 \text{ in}$$

Live Load Deflection

$$\Delta_l := \frac{5 \cdot w_{lane} \cdot L^4}{384 \cdot E_c \cdot I_e} + \frac{b \cdot r \cdot M_{tandem}}{\min(E_1, E_2) \cdot 24 \cdot E_c \cdot I_e} \left( 3 \cdot L^2 - 4 \left( \frac{L-4 \text{ ft}}{2} \right)^2 \right) = 0.44 \text{ in}$$

### Temperature Calculations

Coefficient of Thermal Expansion

$$\alpha := 6 \cdot 10^{-6}$$

Change in Temperature

$$\Delta T := 90$$

Temperature Strain  $\epsilon_T := \alpha \cdot \Delta T = 5.4 \cdot 10^{-4}$

Temperature Movement  $TM := \epsilon_T \cdot L = 0.13 \text{ in}$

**Shrinkage Calculations**

Volume-to-Surface Ratio  $VS := h$

Volume-to-Surface Factor  $k_s := \max\left(1, 1.45 - 0.13 \cdot \frac{VS}{\text{in}}\right) = 1$

Relative Humidity  $H := 70\%$

Humidity Factor for Shrinkage  $k_{hs} := 2 - 1.4 \cdot H = 1.02$

Initial Compressive Strength  $f_{ci}' := 2 \text{ ksi}$

Compressive Strength Factor  $k_f := \frac{5 \text{ ksi}}{1 \text{ ksi} + f_{ci}'} = 1.667$

Age at End of Curing  $t_i := 4 \text{ day}$

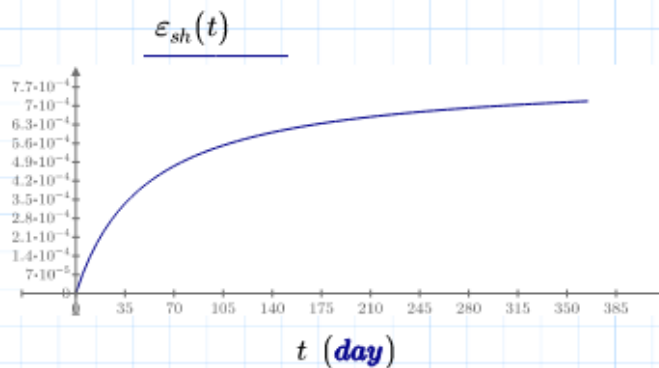
Time from End of Curing  $t := 0,5 \text{ day} \dots 365 \text{ day}$

Time Development Factor  $k_{td}(t) := \frac{t}{12 \left( \frac{100 - 4 \cdot \frac{f_{ci}'}{\text{ksi}}}{20 + \frac{f_{ci}'}{\text{ksi}}} \right) \text{ day} + t}$   $k_{td}(28 \text{ day} - t_i) = 0.324$

Shrinkage Strain  $\epsilon_{sh}(t) := 0.48 \cdot 10^{-3} \cdot k_s \cdot k_{hs} \cdot k_f \cdot k_{td}(t)$

28-day Shrinkage Strain  $\epsilon_{sh}(28 \text{ day} - t_i) = 2.64 \cdot 10^{-4}$

28-day Shrinkage Movement  $SM := \epsilon_{sh}(28 \text{ day} - t_i) \cdot L = 0.063 \text{ in}$



### AASHTO LRFD Crack Control (5.6.7)

Tensile nonprestressed reinforcement ratio	$\rho := \frac{A_s}{b \cdot d} = 0.0125$
The k-Factor	$k := \sqrt{2 n \cdot \rho + (n \cdot \rho)^2} - n \cdot \rho = 0.346$
The j-Factor	$j := 1 - \frac{k}{3} = 0.88$
Tensile stress in nonprestressed reinforcement	$f_{ss} := \frac{M_a}{A_s \cdot j \cdot d} = 32 \text{ ksi}$
Exposure factor (1.0 for class I and 0.75 for class II)	$\gamma_e := 1$
Thickness of concrete cover from center of reinforcement	$d_c := 3.5 \text{ in}$
Ratio of flexure strain to strain in reinforcement strain	$\beta_s := 1 + \frac{d_c}{0.7 (h - d_c)} = 1.476$
Max. spacing of nonprestressed reinforcement	$s_{max} := \frac{700 \text{ ksi} \cdot \text{in} \cdot \gamma_e}{\beta_s \cdot f_{ss}} - 2 d_c = 7.8 \text{ in}$

Used spacing is 6 in., which is OK

### AASHTO LRFD S&T Reinforcement (5.10.6)

Least width of the component	$b := W$
Min. area of reinforcement in each direction per foot	$A_{s,min} := \min \left( 0.6 \frac{\text{in}^2}{\text{ft}}, \max \left( 0.11 \frac{\text{in}^2}{\text{ft}}, \frac{0.0018 \cdot (60 \text{ ksi}) \cdot b \cdot h}{2 \cdot (b + h) \cdot \min(f_y, 75 \text{ ksi})} \right) \right) = 0.15 \frac{\text{in}^2}{\text{ft}}$
Max. spacing of S&T reinforcement	$s_{max} := \min(18 \text{ in}, 3 h) = 18 \text{ in}$

Used reinforcement is #5@12 in., which is OK



### Soil Reaction and Friction

Granular Backfill MOE	$E := 4786 \text{ psi}$	From M106 Project
Modulus of Subgrade Reaction	$K_s := \frac{E}{19.4 \text{ in}} = 247 \text{ pci}$	(Khazanovich et al. 2001)
Tributary Area	$A_T := 1 \text{ ft}^2$	
Spring Stiffness	$K := K_s \cdot A_T = 35.5 \frac{\text{kip}}{\text{in}}$	
Friction Coefficient	$\mu := 0.6$	Between granular backfill and concrete
Horizontal Spring Stiffness	$H := \mu \cdot K = 21.3 \frac{\text{kip}}{\text{in}}$	

### Connector Stiffness Calculations

#### For #6 dowels

Bar Diameter	$d_b := 0.75 \text{ in}$
Bar Inertia	$I_b := \frac{\pi \cdot d_b^4}{64} = 0.016 \text{ in}^4$
Bar Length	$l_b := 4 \text{ in}$
Connector Stiffness	$K_b := \frac{12 E_s \cdot I_b}{l_b^3} = 84 \frac{\text{kip}}{\text{in}}$

#### For #7 dowels

Bar Diameter	$d_b := 0.875 \text{ in}$
Bar Inertia	$I_b := \frac{\pi \cdot d_b^4}{64} = 0.029 \text{ in}^4$
Bar Length	$l_b := 4 \text{ in}$
Connector Stiffness	$K_b := \frac{12 E_s \cdot I_b}{l_b^3} = 156 \frac{\text{kip}}{\text{in}}$

## Design of Reinforced Precast Concrete Approach Slab According to AASHTO LRFD (2017)

### Concrete Parameters

Concrete Compressive Strength	$f'_c := 5 \text{ ksi}$
Concrete Unit Weight	$w_c := 145 \text{ pcf}$
Aggregate Correction Factor	$K_1 := 1.0$
Normal Weight Concrete MOE	$E_c := 120000 \text{ ksi} \cdot K_1 \cdot \left(\frac{w_c}{1000 \text{ pcf}}\right)^2 \cdot \left(\frac{f'_c}{\text{ksi}}\right)^{0.33} = 4291 \text{ ksi}$
Lightweight Factor	$\lambda := \text{if}\left(w_c \leq 100 \text{ pcf}, 0.75, \text{if}\left(w_c \geq 135 \text{ pcf}, 1, 7.5 \cdot \frac{w_c}{1000 \text{ pcf}}\right)\right) = 1$
Normal Weight Concrete MOR	$f_r := 0.24 \cdot \lambda \cdot \sqrt{f'_c \cdot \text{ksi}} = 0.537 \text{ ksi}$
Concrete Ultimate Strain	$\epsilon_{cu} := 0.003$
Design Strip Width	$b := 1 \text{ ft}$
Slab Thickness	$h := 12 \text{ in}$
Section Area	$A := b \cdot h = 144 \text{ in}^2$
Section Modulus	$S_b := \frac{b \cdot h^2}{6} = 288 \text{ in}^3$

### Reinforcement Parameters

Steel Type	ASTM A1035 ChromX 4100
Steel Yield Strength	$f_y := 100 \text{ ksi}$
Steel Ultimate Strength	$f_u := 150 \text{ ksi}$
Steel Modulus of Elasticity	$E_s := 29000 \text{ ksi}$
Area of Tension Steel	$A_s := \frac{12 \text{ in}}{6 \text{ in}} \cdot 0.6 \text{ in}^2 = 1.2 \text{ in}^2$ #7 @ 6"
Depth of Tension Steel	$d := h - 2.5 \text{ in} = 9.5 \text{ in}$
Depth of Extreme Tension Steel	$d_t := h - 2.5 \text{ in} = 9.5 \text{ in}$
Area of Tension Steel	$A_s' := 1 \cdot 0.31 \text{ in}^2 = 0.31 \text{ in}^2$ #5 @ 12"
Depth of Tension Steel	$d' := 2.5 \text{ in} = 2.5 \text{ in}$

### **Flexural Strength Calculations**

Stress Block Factor 1  $\beta_1 := \min \left( 0.85, \max \left( 0.65, 0.85 - \left( \frac{f'_c}{\text{ksi}} - 4 \right) \cdot 0.05 \right) \right) = 0.8$

Stress Block Factor 2  $\alpha_1 := \max \left( 0.75, \min \left( 0.85, 0.85 - \left( \frac{f'_c}{\text{ksi}} - 10 \right) \cdot 0.02 \right) \right) = 0.85$

Strain in Compression Steel  $\epsilon'_s(c) := \frac{c-d'}{c} \cdot \epsilon_{cu}$

Stress in Compression Steel

$$f'_s(c) := \text{if} \left( |\epsilon'_s(c)| \leq 0.0024, E_s \cdot \epsilon'_s(c), \text{if} \left( |\epsilon'_s(c)| \geq 0.02, f_u, 170 \text{ ksi} - \frac{0.4317 \text{ ksi}}{|\epsilon'_s(c)| + 0.0019} \right) \cdot \frac{\epsilon'_s(c)}{|\epsilon'_s(c)|} \right)$$

Force in Compression Steel  $C_s(c) := A_s' \cdot \text{if} (\beta_1 \cdot c > d', \min(80 \text{ ksi}, f'_s(c)) - \alpha_1 f'_c, f'_s(c))$

Compression in Concrete  $C_c(c) := \alpha_1 \cdot f'_c \cdot b \cdot \beta_1 \cdot c$

Strain in Tension Steel  $\epsilon_s(c) := \frac{d-c}{c} \cdot \epsilon_{cu}$

Stress in Tension Steel

$$f_s(c) := \text{if} \left( |\epsilon_s(c)| \leq 0.0024, E_s \cdot \epsilon_s(c), \text{if} \left( |\epsilon_s(c)| \geq 0.02, f_u, 170 \text{ ksi} - \frac{0.4317 \text{ ksi}}{|\epsilon_s(c)| + 0.0019} \right) \cdot \frac{\epsilon_s(c)}{|\epsilon_s(c)|} \right)$$

Force in Tension Steel  $T(c) := A_s \cdot \text{if} (\beta_1 \cdot c > d, f_s(c) - \alpha_1 f'_c, f_s(c))$

Depth of Neutral Axis  $c_{eq} := \text{root} (C_c(c) + C_s(c) - T(c), c, 0.001 \text{ in}, h) = 3.24 \text{ in}$

Stress in Compression Steel  $f'_s(c_{eq}) = 19.8 \text{ ksi}$

Stress in Tension Steel  $f_s(c_{eq}) = 114 \text{ ksi}$

Compression Block Depth  $a := \beta_1 \cdot c_{eq} = 2.588 \text{ in}$

Nominal Flexural Strength  $M_n := C_c(c_{eq}) \cdot \left( d - \frac{a}{2} \right) + C_s(c_{eq}) \cdot (d - d') = 93.1 \text{ kip} \cdot \text{ft}$

Strain in Extreme Tension Steel  $\epsilon_t := \frac{d - c_{eq}}{c_{eq}} \cdot \epsilon_{cu} = 0.0058$

$check := \text{if} (\epsilon_t \geq 0.0066, \text{"Ten. Control"}, \text{if} (\epsilon_t \geq 0.0042, \text{"Trans."}, \text{"Com. Control"})) = \text{"Trans."}$

Strength Reduction Factor  $\phi := \min \left( 0.9, \max \left( 0.65, 0.65 + 0.25 \cdot \frac{\epsilon_t - 0.0042}{0.0066 - 0.0042} \right) \right) = 0.82$

Design Flexural Strength  $M_r := \phi \cdot M_n = 76.1 \text{ ft} \cdot \text{kip}$

Cracking Moment  $M_{cr} := S_b \cdot f_r = 12.9 \text{ kip} \cdot \text{ft}$

### **Demand Calculations**

Approach Slab Span	$L := 20 \text{ ft}$
Approach Slab Width	$W := 46.67 \text{ ft}$
Skew Angle	$\theta := 0 \text{ deg}$
Reduction of Longitudinal Effects	$r := \min(1, 1.05 - 0.25 \cdot \tan(\theta)) = 1$
Barrier/Rail Weight	$w_r := 0.45 \text{ klf}$
Dead Load	$w_d := 150 \text{ pcf} \cdot h \cdot b + \frac{2 \cdot w_r}{W} \cdot b = 0.169 \text{ klf}$
Dead Load Moment	$M_d := w_d \cdot \frac{L^2}{8} = 8.46 \text{ kip} \cdot \text{ft}$
Critical Shear Section Distance	$x := 12 \text{ in} + \frac{d}{2} = 16.75 \text{ in}$
Dead Load Shear	$V_d := w_d \cdot \left(\frac{L}{2} - x\right) = 1.457 \text{ kip}$
Future Wearing Surface Load	$w_s := 25 \text{ psf} \cdot b = 0.025 \text{ klf}$
Future Wearing Surface Moment	$M_s := w_s \cdot \frac{L^2}{8} = 1.25 \text{ kip} \cdot \text{ft}$
Future Wearing Surface Shear	$V_s := w_s \cdot \left(\frac{L}{2} - x\right) = 0.22 \text{ kip}$
Lane Load	$w_{lane} := 64 \text{ psf} \cdot b = 0.064 \text{ klf}$
Lane Load Moment	$M_{lane} := w_{lane} \cdot \frac{L^2}{8} = 3.2 \text{ kip} \cdot \text{ft}$
Lane Load Shear	$V_{lane} := w_{lane} \cdot \left(\frac{L}{2} - x\right) = 0.551 \text{ kip}$
Tandem Load Moment per Lane	$M_{tandem} := 25 \text{ kip} \cdot \frac{(L - 4 \text{ ft})}{2} = 200 \text{ kip} \cdot \text{ft}$
Tandem Load Shear per Lane	$V_{tandem} := 50 \text{ kip} - 50 \text{ kip} \cdot \frac{x}{L} - \frac{100 \text{ kip} \cdot \text{ft}}{L} = 41.5 \text{ kip}$
Equivalent Width (one lane)	$E_1 := 10 \text{ in} + \frac{5 \cdot \sqrt{\min(L, 60 \text{ ft}) \cdot \min(W, 30 \text{ ft})}}{12} = 132 \text{ in}$
Number of Design Lanes	$N_L := \text{trunc}\left(\frac{W}{12 \text{ ft}}\right) = 3$
Equivalent Width (multiple lanes)	$E_2 := \min\left(84 \text{ in} + \frac{1.44 \cdot \sqrt{\min(L, 60 \text{ ft}) \cdot \min(W, 60 \text{ ft})}}{12}, \frac{W}{N_L}\right) = 128 \text{ in}$

Service Moment  $M_a := M_d + M_s + M_{lane} + \frac{b \cdot r \cdot 1.33 \cdot M_{tandem}}{\min(E_1, E_2)} = 37.9 \text{ kip} \cdot \text{ft}$

$check := \text{if}(M_a > M_{cr}, \text{"Cracked Section"}, \text{"Uncracked Section"}) = \text{"Cracked Section"}$

Cracking-to-Applied Ratio  $R := \frac{M_{cr}}{M_a} = 0.34$

Ultimate Moment  $M_u := 1.25 \cdot M_d + 1.5 \cdot M_s + 1.75 \cdot \left( M_{lane} + \frac{b \cdot r \cdot 1.33 \cdot M_{tandem}}{\min(E_1, E_2)} \right) = 61.7 \text{ kip} \cdot \text{ft}$

$check := \text{if}(M_u > M_r, \text{"Inadequate Section"}, \text{"Adequate Section"}) = \text{"Adequate Section"}$

Flexure Capacity-to-Demand Ratio  $CD := \frac{M_r}{M_u} = 1.23$

Ultimate Shear  $V_u := 1.25 \cdot V_d + 1.5 \cdot V_s + 1.75 \cdot \left( V_{lane} + \frac{b \cdot r \cdot 1.33 \cdot V_{tandem}}{\min(E_1, E_2)} \right) = 12.2 \text{ kip}$

### Stresses During Lifting

Length of Panel Overhang  $o := 5 \text{ ft}$

Negative Moment at Lifting  $M_{ne} := 1.5 \cdot 150 \text{ pcf} \cdot b \cdot h \cdot \frac{o^2}{2} = 2.81 \text{ kip} \cdot \text{ft}$

Positive Moment at Lifting  $M_{po} := 1.5 \cdot 150 \text{ pcf} \cdot b \cdot h \cdot \frac{(L-o)^2}{8} - M_{ne} = 3.52 \text{ kip} \cdot \text{ft}$

### Shear Strength Calculations

Factor of concrete ability to transmit shear  $\beta := 2$  For h less than 16 in.

Nominal Shear Resistance of Concrete  $V_c := 0.0316 \cdot \beta \cdot \lambda \cdot \sqrt{f'_c \cdot \text{ksi}} \cdot b \cdot d = 16.1 \text{ kip}$

Strength Reduction Factor for Shear  $\phi_v := 0.9$

$check := \text{if}(V_u > \phi_v \cdot V_c, \text{"Inadequate Section"}, \text{"Adequate Section"}) = \text{"Adequate Section"}$

Capacity-to-Demand Ratio  $CD := \frac{\phi_v \cdot V_c}{V_u} = 1.19$

### Deflection Calculations

Modular Ratio  $n := \frac{E_s}{E_c} = 6.76$

Location of Neutral Axis  $x := \text{root} \left( \frac{b \cdot x^2}{2} + A_s' \cdot (n-1) (x-d') - A_s \cdot n \cdot (d-x), x, 0, h \right) = 2.94 \text{ in}$

Cracked Section Moment of Inertia  $I_{cr} := \frac{b \cdot x^3}{3} + A_s \cdot n \cdot (d - x)^2 + A_s' \cdot (n - 1) \cdot (x - d')^2 = 451 \text{ in}^4$

Gross Moment of Inertia  $I_g := \frac{b \cdot h^3}{12} = 1728 \text{ in}^4$

Effective Moment of Inertia  $I_e := R^3 \cdot I_g + (1 - R^3) \cdot I_{cr} = 501 \text{ in}^4$

Dead Load Deflection  $\Delta_d := \frac{5 \cdot (w_d + w_s) \cdot L^4}{384 \cdot E_c \cdot I_g} = 0.09 \text{ in}$

Live Load Deflection  $\Delta_l := \frac{5 \cdot w_{lane} \cdot L^4}{384 \cdot E_c \cdot I_e} + \frac{b \cdot r \cdot M_{tandem}}{\min(E_1, E_2) \cdot 24 \cdot E_c \cdot I_e} \left( 3 \cdot L^2 - 4 \left( \frac{L - 4 \text{ ft}}{2} \right)^2 \right) = 0.7 \text{ in}$

### **Shrinkage Calculations**

Volume-to-Surface Ratio  $VS := h$

Volume-to-Surface Factor  $k_s := \max \left( 1, 1.45 - 0.13 \cdot \frac{VS}{\text{in}} \right) = 1$

Relative Humidity  $H := 70\%$

Humidity Factor for Shrinkage  $k_{hs} := 2 - 1.4 \cdot H = 1.02$

Initial Compressive Strength  $f_{ci}' := 2.5 \text{ ksi}$

Compressive Strength Factor  $k_f := \frac{5 \text{ ksi}}{1 \text{ ksi} + f_{ci}'} = 1.429$

Age at End of Curing  $t_i := 4 \text{ day}$

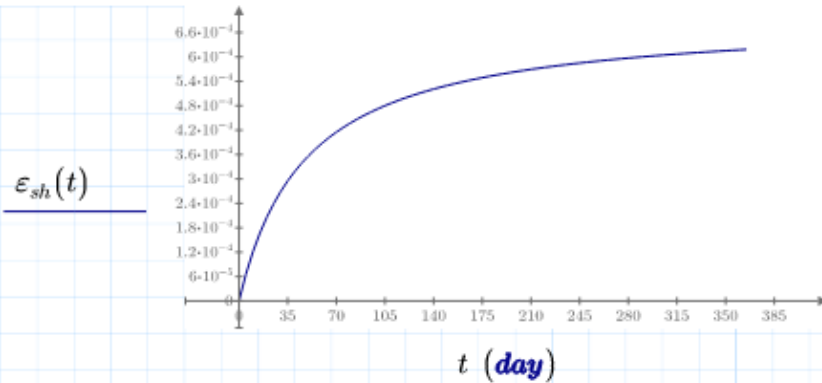
Time from End of Curing  $t := 0,5 \text{ day} \dots 365 \text{ day}$

Time Development Factor  $k_{td}(t) := \frac{t}{12 \left( \frac{100 - 4 \cdot \frac{f_{ci}'}{\text{ksi}}}{20 + \frac{f_{ci}'}{\text{ksi}}} \right) \text{ day} + t}$   
 $k_{td}(28 \text{ day} - t_i) = 0.333$

Shrinkage Strain  $\varepsilon_{sh}(t) := 0.48 \cdot 10^{-3} \cdot k_s \cdot k_{hs} \cdot k_f \cdot k_{td}(t)$

28-day Shrinkage Strain  $\varepsilon_{sh}(28 \text{ day} - t_i) = 2.33 \cdot 10^{-4}$

28-day Shrinkage Movement  $SM := \varepsilon_{sh}(28 \text{ day} - t_i) \cdot L = 0.056 \text{ in}$



### **AASHTO LRFD Crack Control (5.6.7)**

Tensile nonprestressed reinforcement ratio	$\rho := \frac{A_s}{b \cdot d} = 0.0105$
The k-Factor	$k := \sqrt{2 n \cdot \rho + (n \cdot \rho)^2} - n \cdot \rho = 0.313$
The j-Factor	$j := 1 - \frac{k}{3} = 0.9$
Tensile stress in nonprestressed reinforcement	$f_{ss} := \frac{M_a}{A_s \cdot j \cdot d} = 44.5 \text{ ksi}$
Exposure factor (1.0 for class I and 0.75 for class II)	$\gamma_e := 1$
Thickness of concrete cover from center of reinforcement	$d_c := 2.5 \text{ in}$
Ratio of flexure strain to strain in reinforcement strain	$\beta_s := 1 + \frac{d_c}{0.7 (h - d_c)} = 1.376$
Max. spacing of nonprestressed reinforcement	$s_{max} := \frac{700 \text{ ksi} \cdot \text{in} \cdot \gamma_e}{\beta_s \cdot f_{ss}} - 2 d_c = 6.4 \text{ in}$
	Used spacing is 6 in., which is OK

### **AASHTO LRFD S&T Reinforcement (5.10.6)**

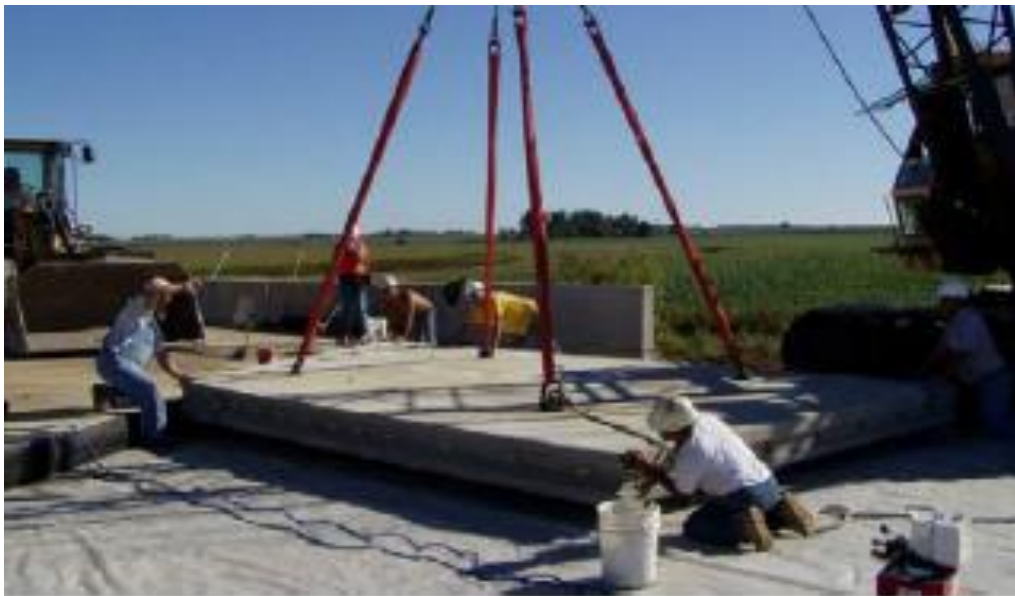
Least width of the component	$b := 12 \text{ ft}$
Min. area of reinforcement in each direction per foot	$A_{s,min} := \min \left( 0.6 \frac{\text{in}^2}{\text{ft}}, \max \left( 0.11 \frac{\text{in}^2}{\text{ft}}, \frac{0.0018 \cdot (60 \text{ ksi}) \cdot b \cdot h}{2 \cdot (b + h) \cdot \min(f_y, 75 \text{ ksi})} \right) \right) = 0.11 \frac{\text{in}^2}{\text{ft}}$
Max. spacing of S&T reinforcement	$s_{max} := \min(18 \text{ in}, 3 h) = 18 \text{ in}$
	Used reinforcement is #5@12 in., which is OK

## APPENDIX C: Precast Concrete Approach Slab Construction

### Approach Slab on Highway 60 Bridge near Sheldon, IA



Panel base preparation



Panel installation





Matching adjacent panels



Threading longitudinal post-tensioning strands



Stressing longitudinal post-tensioning strands



Casting longitudinal joint



Grouting underneath the precast panels



Matching panels at the end of floor



Misalignment of ducts



Damage at panel corners

**Approach Slab at Big Brown Creek Bridge on River Road (S-86), Union  
County, SC**



Panel base preparation



Vertical dowels for the end of floor connection



Panel installation over polyethylene sheeting



Complete installation of skewed panels



Reinforcement of longitudinal joints



Casting longitudinal joints





Asphalt cracking at paving end of the approach slabs

**Approach Slab at Belden-Laurel Bridge on US 20, Cedar County, NE**



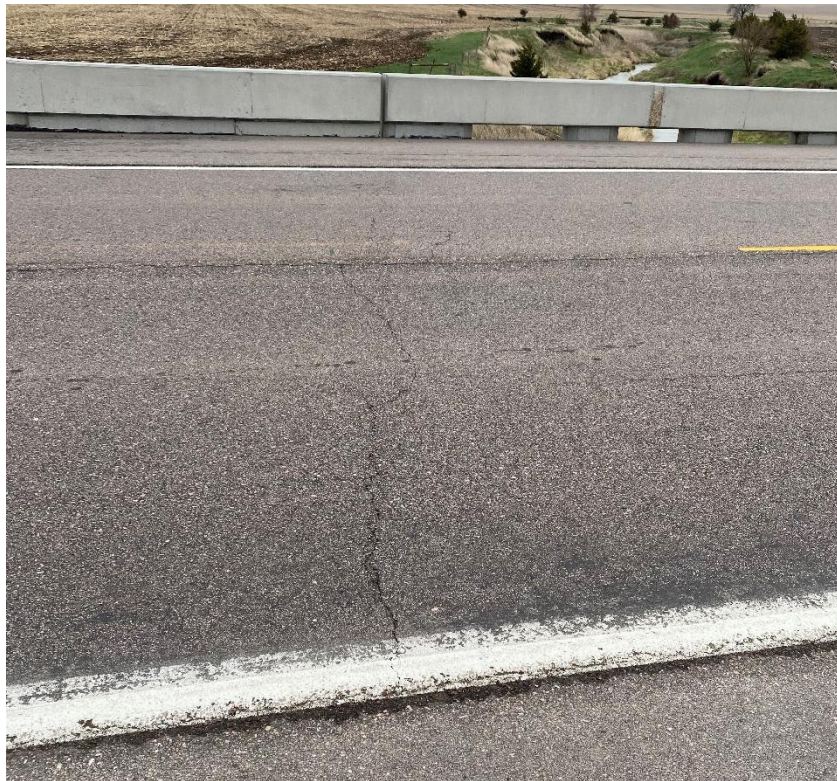
End of Floor Connection



Longitudinal Joints



Asphalt cracking at the end of paving section (left) and expansion joint (right)



Asphalt cracking at the end of floor

**Paving Section Slab on I-680 / West Center Bridge, Douglas County, NE**



Forming paving section panels



Panel curing



Panel installation



Precast panel joints and connections