

WELCOME!

We are pleased you are here to learn more about
and provide feedback on the proposed projects.

NH-83-2(132); C.N. 61363

Leota St – Philip St (SB), North Platte

NH-83-2(130); C.N. 61361

Philip St – 1st St (SB), North Platte

HOW TO GET THE MOST OUT OF THIS MEETING:



Review each display and
talk with project team
members to learn more
and share your ideas.



Spend as much
or as little
time with us
as you like.



Complete a
comment form
and drop it
in the box.

Leota St – Philip St (SB), North Platte NH-83-2(132); C.N. 61363 Philip St – 1st St (SB), North Platte NH-83-2(130); C.N. 61361

Leota St - Philip St (SB), North Platte
83-2(132) C.N. 61363



Philip St - 1st St (SB), North Platte
83-2(130) C.N. 61361

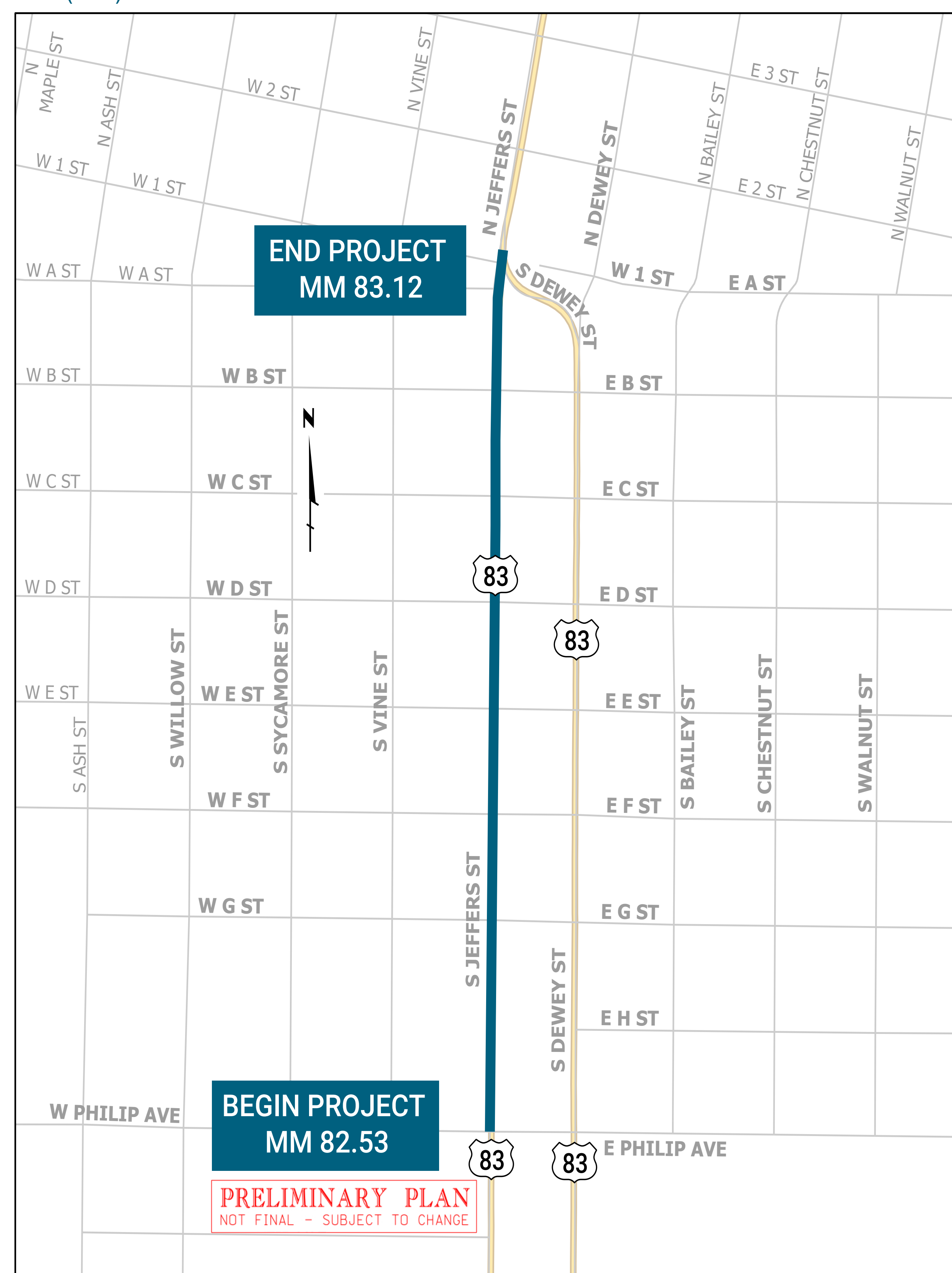

Purpose & Need

The purpose of these projects is to preserve the transportation asset, improve the reliability of the transportation system, and ensure the mobility of the traveling public. The need for the proposed projects is based on the current condition of the existing roadway.

Project & Phases

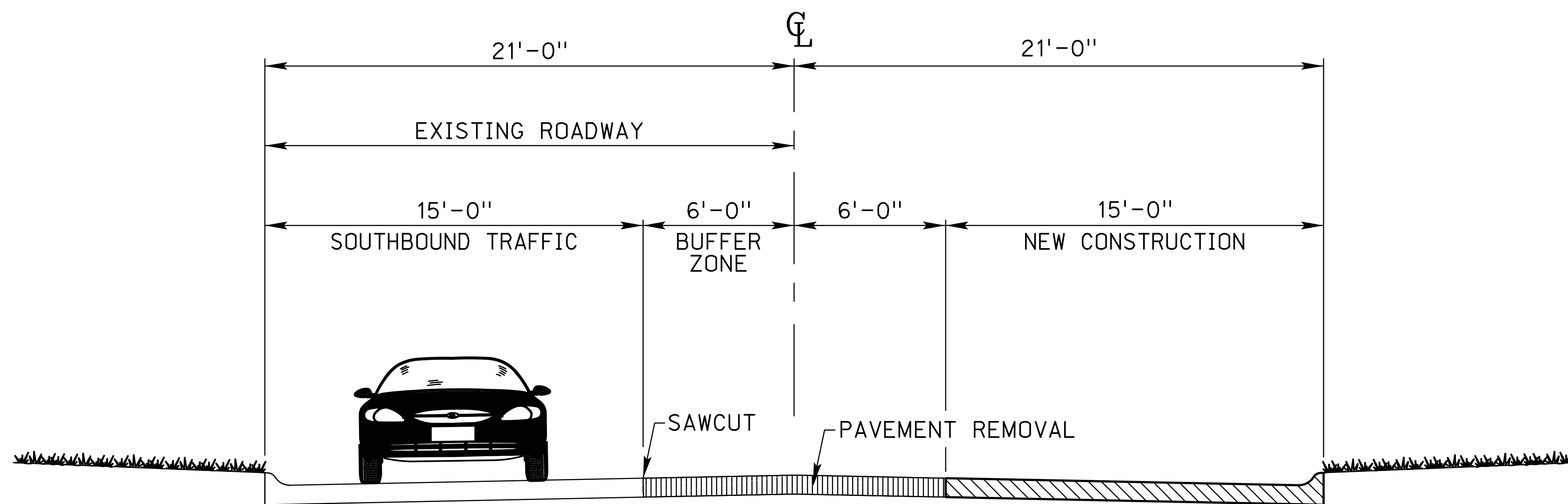

PHASE 1

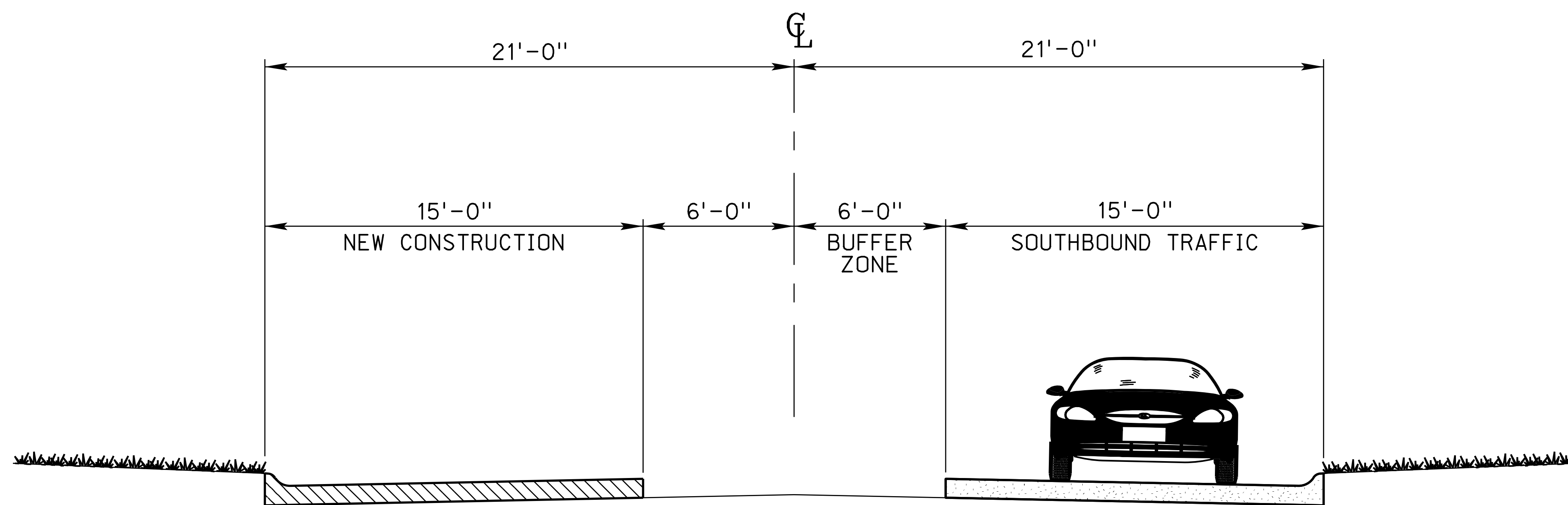

PHASE 2

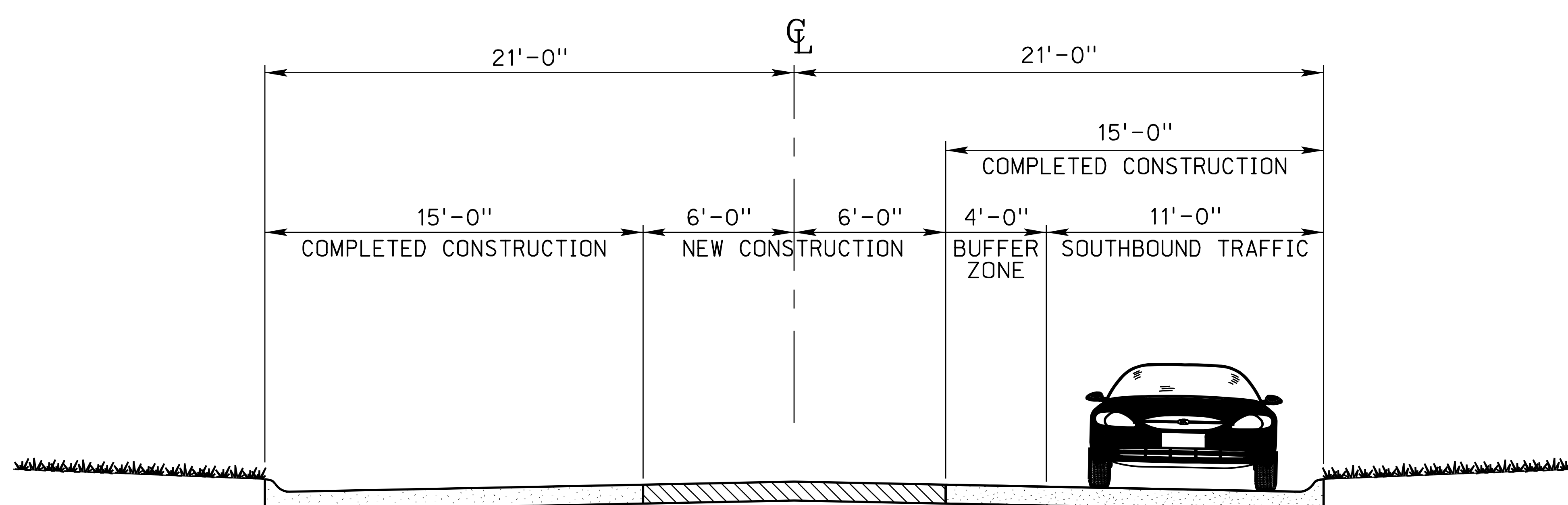

PHASE 3

PRELIMINARY PLAN
NOT FINAL - SUBJECT TO CHANGE

Leota St - Philip St (SB), North Platte NH-83-2(132); C.N. 61363
Philip St - 1st St (SB), North Platte NH-83-2(130); C.N. 61361

Cross Section

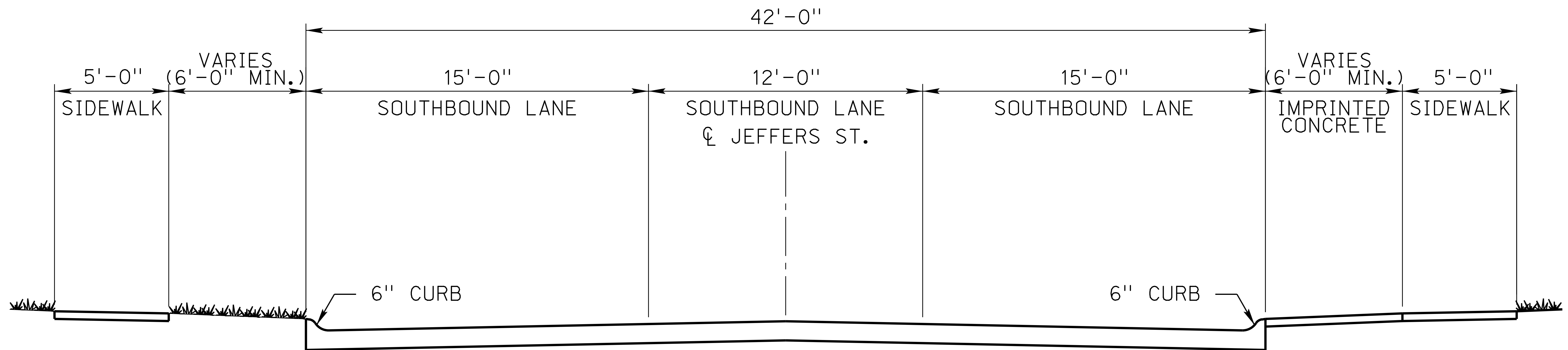

US-83 (JEFFERS ST.) TYPICAL

PRELIMINARY PLAN
NOT FINAL - SUBJECT TO CHANGE

Leota St – Philip St (SB), North Platte NH-83-2(132); C.N. 61363
Philip St – 1st St (SB), North Platte NH-83-2(130); C.N. 61361

Project Timeline

As currently planned, construction could begin as early as spring of 2023 and be completed by winter of 2024.

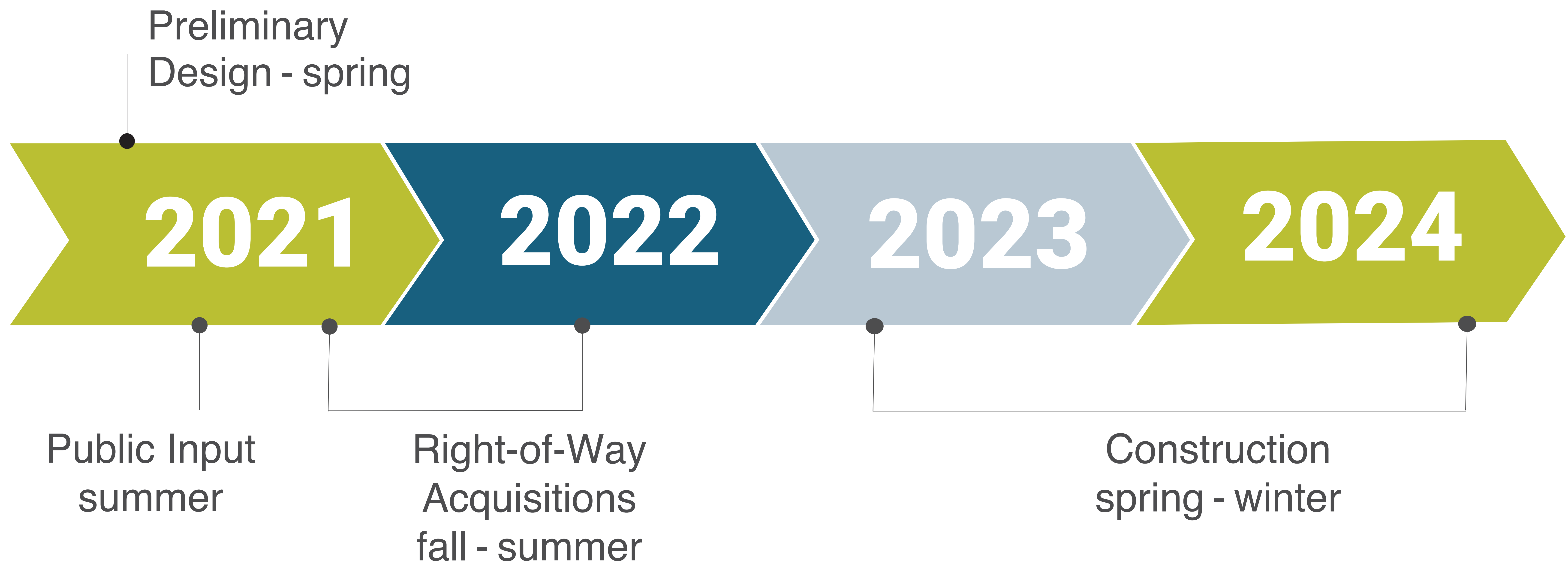

PRELIMINARY PLAN
NOT FINAL - SUBJECT TO CHANGE

Leota St – Philip St (SB), North Platte NH-83-2(132); C.N. 61363

Philip St – 1st St (SB), North Platte NH-83-2(130); C.N. 61361

Leota St - Philip St (SB), North Platte
83-2(132) C.N. 61363



Philip St - 1st St (SB), North Platte
83-2(130) C.N. 61361

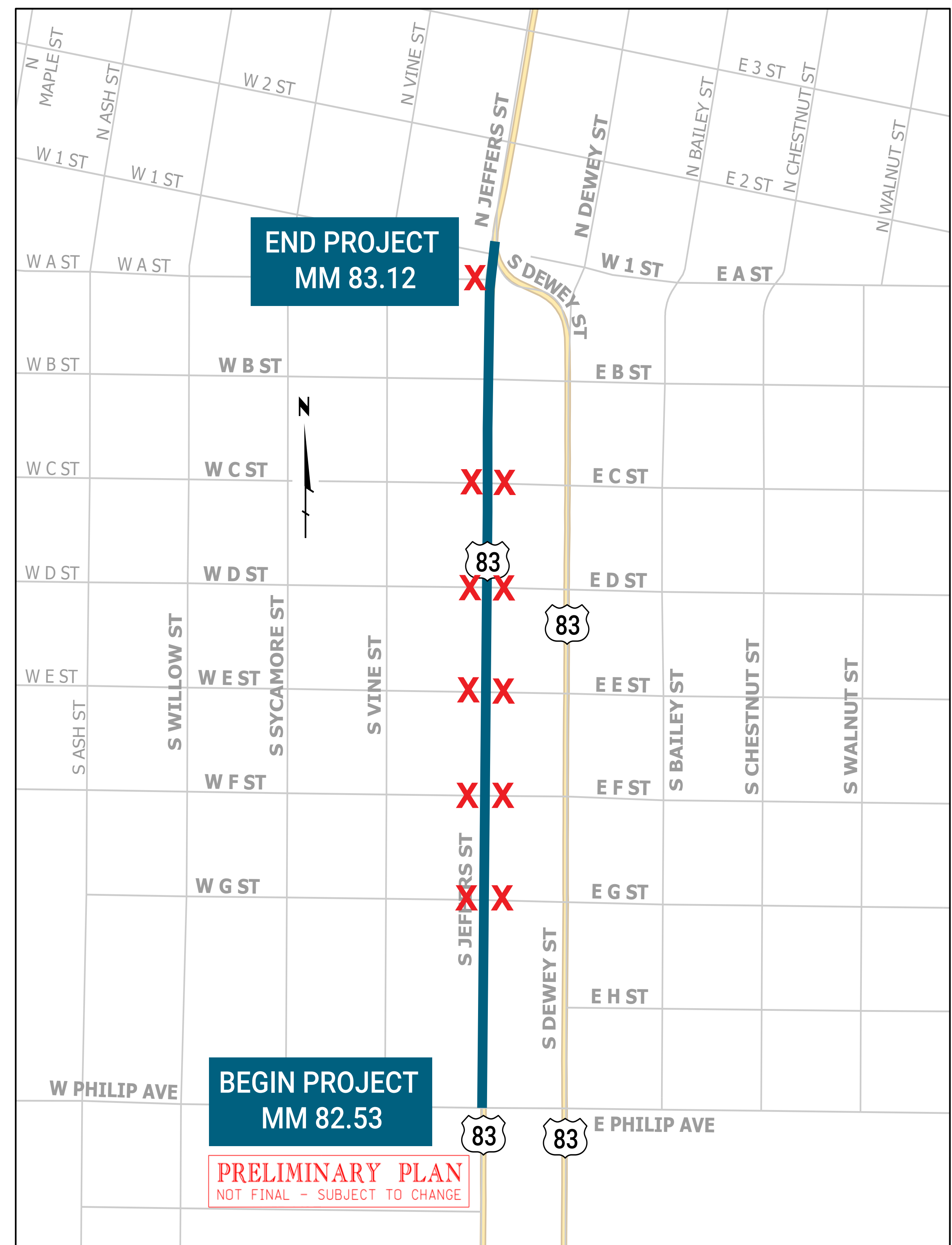

X Temporary side street closure*

*Temporary side street closures would occur at different times during construction, not all at once.

Location Closure Maps

The proposed projects would require alternating temporary closures of side streets along US-83.